



IMPORTANT

BEFORE USING THE PRODUCT,

To maintain safety:

BE SURE TO READ THE FOLLOWING

To ensure the safe operation of this product, be sure to read the following before usage. The following instructions are intended for the users, operators and the personnel in charge of the operation of the product. After carefully reading and sufficiently understanding the warning displays and cautions, handle the product appropriately. Be sure to keep this manual close to the product or in a convenient place for future reference.

Herein, explanations which require special attention are enclosed with dual lines. Depending on the potentially hazardous degrees, the terms of DANGER, WARNING, CAUTION, etc. are used. Be sure to understand the contents of the displays before reading the text.



Indicates that mishandling the product by disregarding this pictograph will cause severe injury or death.



Indicates that mishandling the product by disregarding this caution will cause a slight hazardous situation which can result in personal injury and/or material damage.



Indicates that mishandling the product by disregarding this warning will cause a potentially hazardous situation which can result in death or serious injury.

For the safe usage of the product, the following pictographs are used:



Indicates "HANDLE WITH CARE." In order to protect the human body and equipment, this display is attached to places where the Owner's Manual, Serviceman Manual and/or Service Manual should be referred to.



Indicates a "Protective Earth Terminal." Before operating the equipment, be sure to connect it to the Ground.
(The step may be omitted for products in which a power cord with earth is used.)

- **Perform work in accordance with the instructions herein stated.**
Instructions for work are explained by paying attention to the aspect of accident prevention. Failing to perform work as per the instructions can cause accidents. In the case where only those who have technical expertise should perform the work to avoid hazardous situation, the instructions herein state that the site maintenance personnel should perform such work.
- **Be sure to turn off the power before working on the machine.**
To prevent an electric shock, be sure to turn off the power before carrying out any work that requires direct contact with the interior of the product. If the work is to be performed in the power-on status, the Instruction Manual herein always states to that effect.
- **Be sure to ground the Earth Terminal.**
(This is not required in the case where a power cord with earth is used.)
This product is equipped with the Earth Terminal. When installing the product, connect the Earth Terminal to the "accurately grounded indoor earth terminal" by using an earth wire. Unless the product is grounded appropriately, the user can be subject to an electric shock. After performing repair, etc. for the control equipment, ensure that the Earth Wire is firmly connected to the control equipment.
- **Ensure that the Power Supply used is equipped with an Earth Leakage Breaker.**
This product does not incorporate the Earth Leakage Breaker. Using a power supply which is not equipped with the Earth Leakage Breaker can cause a fire when earth leakage occurs.
- **Be sure to use fuses which meet the specified rating.**
(Only for the machines which use fuses.)
Using fuses exceeding the specified rating can cause a fire and an electric shock.

- **Specification changes (removal of equipment, conversion and addition) not designated by SEGA are not allowed.**

The parts of the product include warning labels for safety, covers for personal protection, etc. It is very hazardous to operate the product by removing parts and/or modifying the circuits. Should doors, lids and protective parts be damaged or lost, refrain from operating the product, and contact where the product was purchased from or the office herein stated. SEGA shall not be held responsible for any accidents, compensation for damage to a third party, resulting from the specifications not designated by SEGA.

- **Ensure that the product meets the requirements of appropriate Electrical Specifications.**

Before installing the product, check for Electrical Specifications. SEGA products have a nameplate on which Electrical Specifications are described. Ensure that the product is compatible with the power supply voltage and frequency requirements of the location. Using any Electrical Specifications different from the designated Specifications can cause a fire and an electric shock.

- **Install and operate the product in places where appropriate lighting is available, allowing warning labels to be clearly read.**

To ensure safety for the customers, labels and printed instructions describing potentially hazardous situations are applied to places where accidents can be caused. Ensure that where the product is operated has sufficient lighting allowing the warnings to be read. If any label is peeled off, apply it again immediately. Please place an order with where the product was purchased from or the office herein stated.

- **When handling the monitor, be very careful. (Applies only to the product with a monitor.)**

Some of the monitor (TV) parts are subject to high tension voltage. Even after turning off the power, some portions are still subject to high tension voltage sometimes. Monitor repair and replacement should be performed only by those technical personnel who have knowledge of

- **Be sure to adjust the monitor/projector properly. (Applies only to the product with a monitor/projector.)**

electricity and technical expertise. Do not operate the product leaving on-screen flickering or blurring as it is. Using the product with the monitor/projector not properly adjusted may cause dizziness or a headache to an operator, a player, or the customers.

- **When transporting or reselling this product, be sure to attach this manual to the product.**

In the case where commercially available monitors and printers are used in this product, only the contents relating to this product are explained herein. Some commercially available equipment has functions and reactions not stated in this manual. Read this manual together with the specific Instruction Manual of such equipment.

** Descriptions herein contained may be subject to improvement changes without notice.*

** The contents described herein are fully prepared with due care. However, should any question arise or errors be found, please contact SEGA.*

INSPECTIONS IMMEDIATELY AFTER TRANSPORTING THE PRODUCT TO THE LOCATION

Normally, at the time of shipment, SEGA products are in a status allowing for usage immediately after transporting to the location. Nevertheless, an irregular situation may occur during transportation. Before turning on the power, check the following points to ensure that the product has been transported in a satisfactory status.

- Are there any dented portions or defects (cuts, etc.) on the external surfaces of the cabinet?
- Are Casters and Adjusters damaged?
- Do the power supply voltage and frequency requirements meet with those of the location?
- Are all wiring connectors correctly and securely connected? Unless connected in the correct way, connector connections can not be made accurately. Do not insert connectors forcibly.
- Do power cords have cuts and dents?
- Do the fuses used meet specified ratings? Is the Circuit Protector in an energized status?
- Are all accessories available?
- Can all Doors and Lids be opened with the Accessory Keys? Can Doors and Lids be firmly closed?

TABLE OF CONTENTS

BEFORE USING THE PRODUCT, BE SURE TO READ THE FOLLOWING:

TABLE OF CONTENTS.....	i
INTRODUCTION.....	iv
HANDLING PRECAUTIONS.....	1
2 PRECAUTIONS REGARDING INSTALLATION LOCATION	4
2-1 LIMITATIONS OF USAGE.....	5
2-2 OPERATION AREA.....	6
3 PRECAUTIONS REGARDING PRODUCT OPERATION	7
3-1 BEFORE OPERATION.....	7
3-2 DURING OPERATION (PAYING ATTENTION TO CUSTOMERS)	9
4 PART DESCRIPTION.....	11
5 ACCESORIES	12
ASSEMBLY AND INSTALLATION.....	13
6-1 ATTACHING THE BILLBOARD.....	16
6-2 ATTACHING THE REAR CABINET	18
6-3 FASTENING THE PRODUCT TO THE INSTALLATION LOCATION.....	20
6-4 ATTACHING THE COIN CHUTE TOWER.....	22
6-5 INSTALLING THE MAT.....	27
6-6 CONNECTION OF POWER AND GROUND WIRE	28
6-7 CHECKING THE ASSEMBLY	30
PRECAUTIONS WHEN MOVING THE MACHINE	33
GAME DESCRIPTION.....	35
8-1 HOW TO PLAY.....	35
8-2 STORY MODE	36
8-3 VERSUS MODE.....	39
8-4 HINTS FOR PLAYING THE GAME.....	41
EXPLANATION OF TEST AND DATA DISPLAY.....	42
9-1 SWITCH UNIT AND COIN METER	44
9-2 SYSTEM TEST MODE	45
9-3 GAME TEST MODE	47

9-3-1	GAME TEST MODE.....	47
9-3-2	INPUT TEST.....	48
9-3-3	OUTPUT TEST.....	50
9-3-4	GAME ASSIGNMENTS.....	53
9-3-5	INPUT ADJUSTMENT.....	55
9-3-6	NETWORK SETTING.....	56
9-3-7	BOOKKEEPING.....	58
9-3-8	BACKUP DATA CLEAR.....	62
9-4	ERROR MESSAGES.....	63
 HANDLE.....		66
10-1	FRONT BRAKE VOLUME.....	66
10-1-1	Adjusting the Volume	66
10-1-2	Replacing the Volume.....	68
10-1-3	GREASING.....	70
10-2	ACCELERATOR VOLUME	71
10-2-1	Adjusting the Volume	71
10-2-2	Replacing the Volume.....	73
10-2-3	GREASING.....	75
10-3	HANDLE VOLUME.....	76
10-3-1	Adjusting the Volume	76
10-3-2	Replacing the Volume.....	78
10-3-3	GREASING.....	83
 MOTORCYCLE MECHANISM		84
11-1	ROLL (LEAN) VOLUME.....	84
11-1-1	Adjusting the Volume	84
11-1-2	Replacing the Volume.....	86
11-1-3	GREASING.....	89
11-2	REPLACING THE SIDE GUIDE PLATES.....	90
11-3	REPLACING THE VIBRATION UNIT HARNESS	92
 COIN SELECTOR		98
12-1	CLEANING THE COIN SELECTOR.....	98
12-2	HANDLING THE COIN JAM	100
12-3	COIN INSERTION TEST	100
 DLP PROJECTOR.....		101
13-1	CLEANING THE SCREEN	102
 REPLACING THE FLUORESCENT AND HALOGEN LAMPS		103
14-1	REPLACING THE FLUORESCENT LAMP.....	103

PERIODIC INSPECTION.....105

TROUBLESHOOTING107

16-1 TROUBLESHOOTING TABLE.....107

GAME BOARD (LINDBERGH RED EX).....110

17-1 CLEANING THE LINDBERGH BOARD.....111

17-2 COMPOSITION OF GAME BOARD.....112

NETWORK PLAY113

18-1 INSTALLATION PRECAUTIONS.....113

DESIGN RELATED PARTS.....115

PARTS LIST116

WIRE COLOR CODE TABLE.....151

WIRING DIAGRAM152

SEGA AMUSEMENTS OFFICES

INTRODUCTION

This manual is intended to provide detailed descriptions together with all the necessary information covering the general operation of electronic assemblies, electro-mechanicals, servicing control, spare parts, etc. for the product, “**HARLEY-DAVIDSON® KING OF THE ROAD.**”

This manual is intended for the owners, personnel and managers in charge of operation of the product. Operate the product after carefully reading and sufficiently understanding the instructions.

In the unlikely event that the product does not function correctly, **DO NOT** allow anyone other than a technician to touch the internal system. Turn off the power to the machine, making sure to unplug the electrical cord from the outlet, and contact the office listed below or the point-of-purchase for this product.

Use of this product is unlikely to cause physical injuries or damage to property. However, points that require special attention are indicated by bold text, the word "IMPORTANT" and the symbol below.



Indicates important information that, if ignored, may result in the mishandling of the product and cause faulty operation or damage to the product.

SPECIFICATIONS

Installation space	60 '' (width) x 95 '' (depth) 1,522 mm [Width] x 2,410 mm [Depth]	
Height	95 '' 2,400 mm	
Weight	862 lbs 391 kg	
Power, maximum current	619 W, 6.12 A	Single phase AC 120 V, 60 Hz Area
	614W, 3.20A	Single phase AC230V, 50Hz Area
	623W, 3.09A	Single phase AC 240V, 50Hz Area

Definition of 'Site Maintenance Personnel or Other Qualified Individuals'



Procedures not described in this manual or marked as 'to be carried out by site maintenance personnel or other qualified professionals' should not be carried out by personnel without the necessary skill or technology. Work carried out by unqualified persons may cause serious accidents, including electrocution.

Parts replacement, maintenance inspections and troubleshooting should be carried out by site maintenance personnel or other qualified professionals. This manual includes directions for potentially dangerous procedures which should only be carried out by professionals with the appropriate specialized knowledge.

The site maintenance personnel or other qualified professionals mentioned in this manual are defined as follows:

Site maintenance personnel:

Individuals with experience in maintaining amusement equipment, vending machines, etc., working under the supervision of the owner/operator of this product to maintain machines within amusement facilities or similar premises by carrying out everyday procedures such as assembly, maintenance inspections, and replacement of units/expendable parts.

Activities to be carried out by site maintenance personnel:

Amusement equipment/vending machine assembly, maintenance inspection and replacement of units/expendable parts.

Other qualified professionals:

Persons employed by amusement equipment manufacturers, or involved in design, production, testing or maintenance of amusement equipment. The individual should have either graduated from technical school or hold similar qualifications in electrical/electronics/mechanical engineering.

Activities to be carried out by other qualified professionals:

Amusement equipment/vending machine assembly, repair/adjustment of electrical/electronic/mechanical parts.

1 HANDLING PRECAUTIONS

When installing or inspecting the machine, be very careful of the following points and pay attention to ensure that the player can enjoy the game safely.

Non-compliance with the following points or inappropriate handling running counter to the cautionary matters herein stated can cause personal injury or damage to the machine.

WARNING

- When working with the product, be sure to turn the power off. Working with the power on may cause an electric shock or short circuit.
- To avoid an electric shock or short circuit, do not plug in or unplug quickly.
- To avoid an electric shock, do not plug in or unplug with a wet hand.
- Do not expose power cords or ground wires on the surface, (floor, passage, etc.). If exposed, the power cords and ground wires are susceptible to damage. Damaged cords and wires can cause an electric shock or short circuit.
- To avoid causing a fire or an electric shock, do not put things on or damage the power cords.
- When, or after installing the product, do not unnecessarily pull the power cord. If damaged, the power cord can cause a fire or an electric shock.
- In case the power cable is damaged, ask for a replacement through where the product was purchased from or the office herein stated. Using the cord as is damaged can cause fire, an electric shock or leakage.
- Be sure to perform grounding appropriately. Inappropriate grounding can cause an electric shock.
- Be sure to use fuses meeting the specified rating. Using fuses exceeding the specified rating can cause a fire or an electric shock.
- Be sure that connections such as IC BD are made properly. Insufficient insertion can cause an electric shock.
- Specification changes, removal of equipment, conversion and/or addition, not designated by SEGA are not permitted.
 - Failure to observe this may cause a fire or an electric shock. Non-compliance with this instruction can have a bad influence upon physical conditions of the players or the onlookers, or result in injury during play.
 - SEGA shall not be held responsible for damage, compensation for damage to a third party, caused by specification changes not designated by SEGA.
- If work or parts replacement not indicated in this manual is carried out, an accident may occur. If it is necessary to carry out work not indicated in this manual, be sure to have it done by the office indicated in this manual or by the point of purchase. Also, please inquire regarding details of the work involved.
- Be sure to perform periodic maintenance inspections herein stated.



- For the IC board circuit inspections, only the logic tester is allowed. The use of a multiple-purpose tester is not permitted, so be careful in this regard.
- Static electricity from your body may damage some electronics devices on the IC board. Before handling the IC board, touch a grounded metallic surface so that the static electricity can be discharged.
- This product uses a DLP projector. DLP projector screens scratch easily, so be careful when cleaning the screen. See Chapter 13 (“DLP Projectors”) for details.
- Some parts are not designed and manufactured specifically for this game machine. The manufacturers may discontinue, or change the specifications of such general-purpose parts. If this is the case, SEGA cannot repair or replace a failed game machine whether or not a warranty period has expired.

CONCERNING THE STICKER DISPLAY

This SEGA product has stickers attached describing the product manufacture No. (Serial No.) and Electrical Specifications. It also has a Sticker describing where to contact for repair and for purchasing parts. When inquiring about or asking for repairs, mention the Serial No. and Name of Machine indicated on the Sticker. The Serial Number indicates the product register. Identical machines could have different parts depending on the date of production. Also, improvements and modifications might have been made after the publication of this manual. In order to ensure you order the correct parts, mention the Serial No. when contacting the applicable places.

CONCERNING WARNING DISPLAYS

This SEGA product has warning displays on stickers, labels and/or printed instructions adhered/attached to or incorporated in the places where a potentially hazardous situation could arise. The warning displays are intended for accident prevention for customers and for avoiding hazardous situations relating to maintenance and servicing work. Some portions of the cabinet contain high voltage and may cause accidents if touched. When performing maintenance, be very careful of the warning displays. It is especially important that any complex repair and replacement work not mentioned herein should be performed by those technical personnel who have knowledge of electricity and technical expertise.

In order to prevent accidents, caution any customer ignoring the warnings to cease and desist immediately.

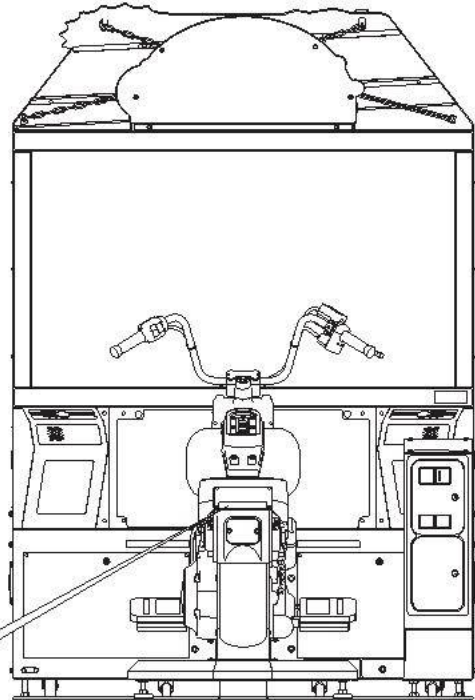
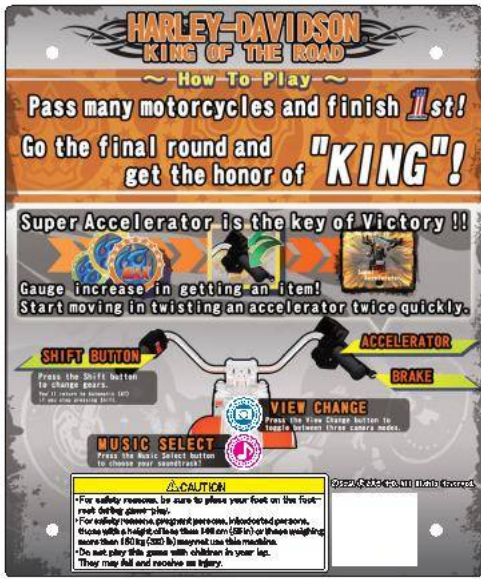

WARNING
Do not ride tandem (with another person) to avoid injury.

440-WS0354-EG

HLT-3019-01

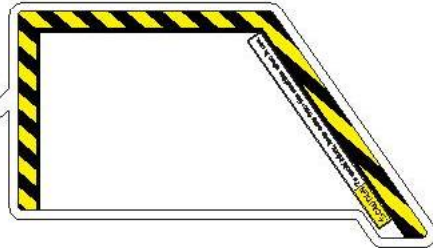

440-WS0275-EG

WARNING
Do not put your hands or fingers here as it may result in injury.

HLT-3018-01



CAUTION
To avoid injury, keep away from the machine when in use.

440-CS0355-EG

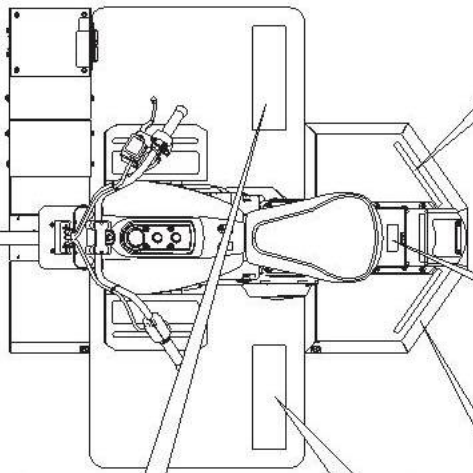
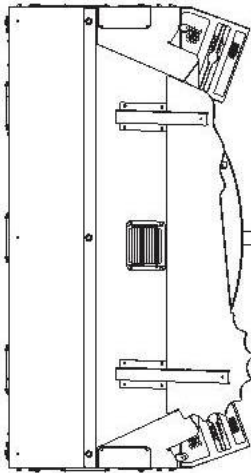

2 PRECAUTIONS REGARDING INSTALLATION LOCATION

WARNING

This product is an indoor game machine. Do not install it outside. Even indoors, avoid installing in places mentioned below so as not to cause a fire, electric shock, injury and/or malfunction.

- Places subject to rain or water leakage, or places subject to high humidity in the proximity of an indoor swimming pool and/or shower, etc.
- Places subject to direct sunlight, or places subject to high temperatures in the proximity of heating units, etc.
- Places filled with inflammable gas or vicinity of highly inflammable/volatile chemicals or hazardous matter.
- Dusty places.
- Sloped surfaces.
- Places subject to any type of violent impact.
- Vicinity of anti-disaster facilities such as fire exits and fire extinguishers.
- Areas where the temperature exceeds the applicable temperature (ambient temperature) range of 5 to 30 degrees centigrade.

2-1 LIMITATIONS OF USAGE

WARNING

- Be sure to check the Electrical Specifications. Ensure that this product is compatible with the location's power supply, voltage, and frequency requirements. A plate describing Electrical Specifications is attached to the product. Noncompliance with the Electrical Specifications can cause a fire and electric shock.
- This product requires a breaker and earth mechanism as part of the location facilities. Using the product without these can cause a fire and electric shock.
- Be sure to use an independent power supply equipped with an earth leakage breaker. Using a power supply without an earth leakage breaker can cause an outbreak of fire if a power surge occurs.
- Putting many loads on one electrical outlet can cause generation of heat and a fire resulting from overload.
- Ensure that the indoor wiring for the power supply is rated at 15 A or higher (AC single phase 100 V ~ 120 V area), and 7 A or higher (AC 220 V ~ 240 V area). Non-compliance with the Electrical Specifications can cause a fire and electric shock.
- When using an extension cord, ensure that the cord is rated at 15 A or higher (AC 100 V ~ 120 V area) and 7 A or higher (AC 220 V ~ 240 V area). Using a cord rated lower than the specified rating can cause a fire and electric shock.

Electricity Consumption:

MAX. 6.12 A	(AC 120 V, 60Hz)
MAX. 3.20 A	(AC 230 V, 50 Hz)
MAX. 3.09 A	(AC 240 V, 50 Hz)

2-2 OPERATION AREA

⚠ WARNING

- For safe operation, use and operate this product in an area measuring at least 2,000 mm in width and 2,600 mm in depth.
- Be sure to provide sufficient space specified in this manual. Do not allow objects to block the ventilation ports. It can cause generation of heat and a fire.
- SEGA shall not be held responsible for damage, compensation for damage to a third party, resulting from the failure to observe this instruction.
- The ceiling where this product is installed must be at least 2,400 mm high. If the ceiling is too low, the heat emitted from the product may cause it to catch on fire.

🚫 IMPORTANT

For transporting the machine into the location's building, the minimum necessary dimensions of the opening (of doors, etc.) are 900 mm (W) and 1,400 mm (H)

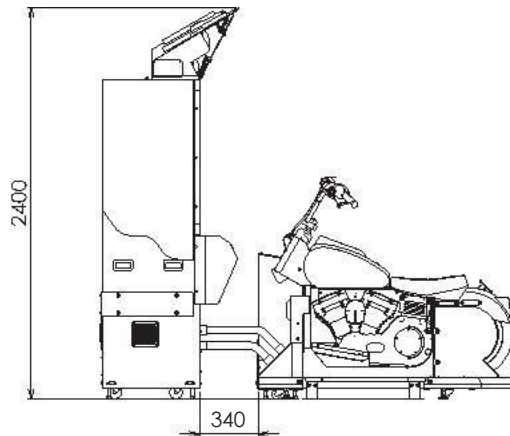
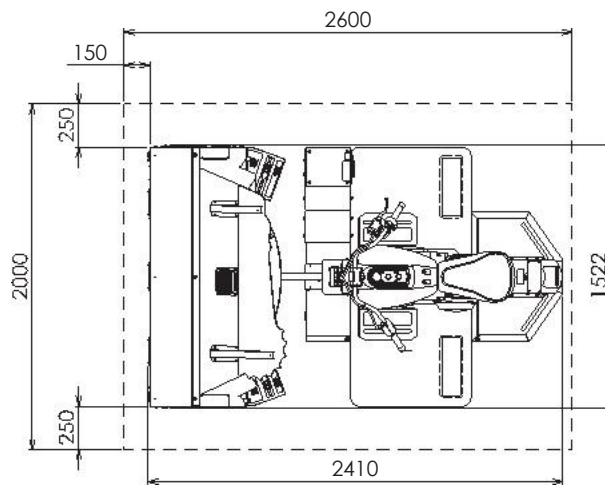

(Unit: mm)

2-2 FIG. 01

3 PRECAUTIONS REGARDING PRODUCT OPERATION

The motorcycle mechanism on this product tilts to the left and right during game play. To avoid injury and trouble, be sure to pay attention to the behavior of visitors and players.

3-1 BEFORE OPERATION

⚠ WARNING

In order to avoid accidents, check the following before starting the operation:

- To ensure maximum safety for the players and the customers, ensure that where the product is operated has sufficient lighting to allow any warnings to be read. Operation under insufficient lighting can cause bodily contact with each other, hitting accident, and/or trouble between customers.
- Be sure to perform appropriate adjustment of the monitor (projector). For operation of this machine, do not leave monitor's flickering or deviation as is. Failure to observe this can have a bad influence upon the players' or the customers' physical conditions.
- It is suggested to ensure a space allowing the players who feel sick while playing the game to take a rest.
- Check if all of the adjusters are in contact with the surface. If they are not, the Cabinet can move and cause an accident.

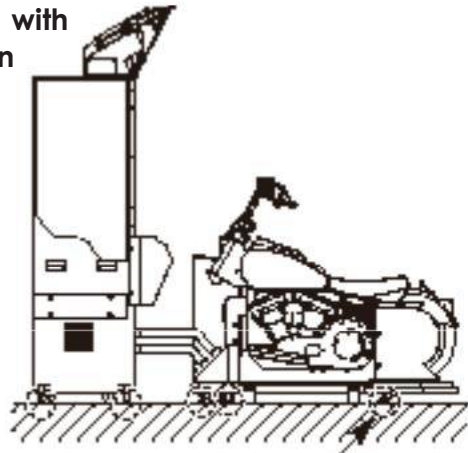

Ensure that all of the adjusters are in contact with the floor.

- Check the side guide plates on the back of the motorcycle mechanism to make sure they are undamaged and intact. If the guide plates are faulty, it could lead to an accident such as the customer getting his or her fingers caught in between the parts.

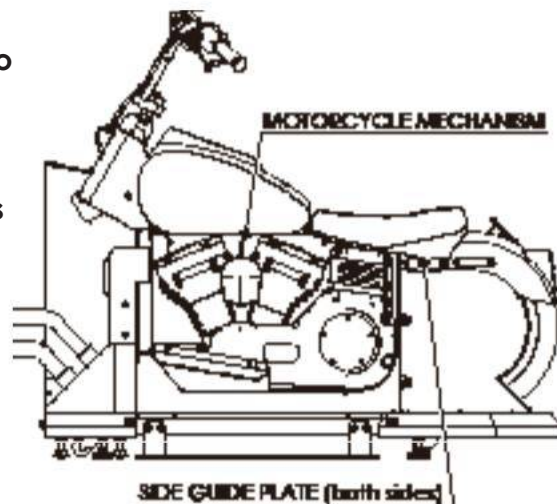

⚠️ WARNING

- Do not put any heavy item on this product. Placing any heavy item on the product can cause a falling down accident or parts damage.
- Do not climb on the product. Climbing on the product can cause falling down accidents. To check the top portion of the product, use a step ladder.
- To avoid electric shock, check to see if door & cover parts are damaged or omitted.
- To avoid electric shock, short circuit and/or parts damage, do not put the following items on or in the periphery of the product.
 - Flower vases, flowerpots, cups, water tanks, cosmetics, and receptacles/containers/vessels containing chemicals and water.
- Check the surrounding area before turning on the power. The product will perform the initializing operation automatically after the power is turned on. If there are people near it, they could be struck or knocked over when the seat moves to the left and right.
- For safety reasons, perform a test run, and be sure to inspect the safety mechanism before making the game available for play. The product is equipped with a safety mechanism as the seat will vibrate (move to the left and right). Be very careful when inspecting the safety mechanism to ensure it works properly.
 - Is the seat loose?
 - Are the side guide plates undamaged and intact?
- Inspect the seat to make sure it moves properly. Abnormal movement of the seat could lead to accidents, so do not make the game available for play until the problem is resolved.
 - Does the seat move in the direction it is steered?
 - Does the seat move smoothly?
 - Is there significant rattling?
 - Are there any unusual noises when the seat moves?
 - Does the seat vibrate in an unusual manner when it moves?
 - Does the seat stop in a level position when the game ends?
- Stop operations immediately if the moving mechanism ever malfunctions. Turn off the power, unplug the power plug from the outlet, and contact the party listed in this manual or the point of purchase for this product. Continued use despite a malfunction could result in major accidents such as electrocution, short circuits, fire, or a fall.
- If the moving mechanism requires maintenance, contact the party listed in this manual or the point of purchase for this product. If maintenance work is performed by someone other than a qualified technician, an accident involving the person performing the maintenance work or persons playing the game may occur.

⚠ CAUTION

To avoid injury, be sure to provide sufficient space by considering the potentially crowded situation at the installation location. The motorcycle mechanism on this product tilts to the left and the right according to the player's steering. Insufficient installation space can cause making bodily contact with each other, hitting accidents, and/or trouble between customers.

3-2 DURING OPERATION (PAYING ATTENTION TO CUSTOMERS)

To avoid injury and trouble, be sure to pay attention to the behavior of visitors and players

⚠ WARNING

- For safety reasons, do not allow any of the following people to play the game.
 - Those who need assistance such as the use of an apparatus when walking.
 - Those who have high blood pressure or a heart problem.
 - Those who have experienced muscle convulsion or loss of consciousness when playing video games, etc.
 - Those who have neck or spinal cord problems.
 - Those who are intoxicated or under the influence of drugs.
 - Pregnant women.
 - Persons susceptible to motion sickness.
 - Persons who disregard the product's warning displays.
 - Persons under 140 cm in height.
 - Persons over 150 kg in weight.
 - Those who cannot grasp the Control Unit securely because of immobility in fingers, hands or arms.
- For safety reasons, persons under 140 cm in height cannot play this game.

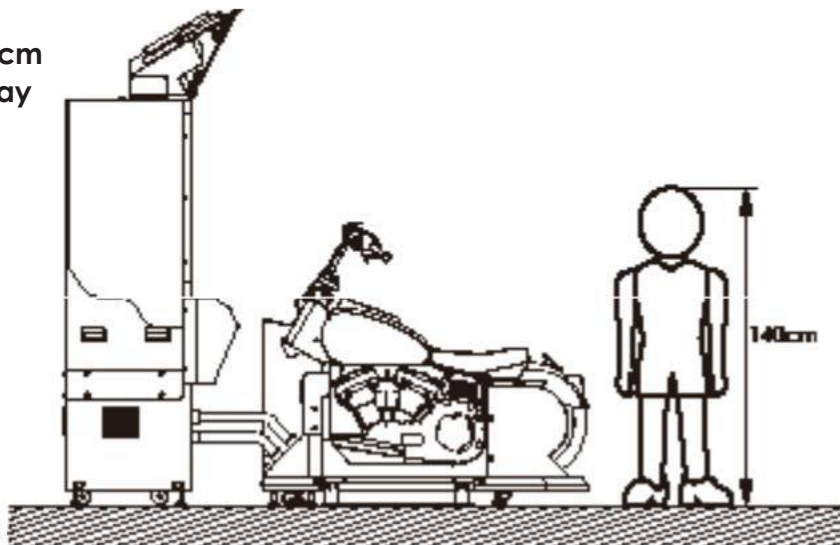

- Instruct players that only 1 person should get on the motorcycle at a time. The product is made for a single rider. If two or more people get on at the same time, they could fall off.

⚠️ WARNING

- Instruct those wearing high-heeled shoes that they should not play the game due to the high risk of having an accident during play.
- Instruct players to straddle the seat when playing the game. The motorcycle mechanism tilts during play, so the player could fall off if both legs are on one side.
- Even players who have never been adversely affected by light stimulus might experience dizziness or headache depending on their physical condition when playing the game. Small children are especially likely to experience these symptoms. Caution guardians of small children to keep watch on their children during play.
- Instruct those who feel sick during play to have a medical examination.
- To avoid injury from falls and electric shocks due to spilled drinks, instruct the player not to place heavy items or drinks on the product.
- To avoid electric shocks and short circuits, do not allow customers to put hands and fingers or extraneous matter in the openings of the product or small openings in or around the doors.
- To avoid falls and resulting injury, immediately stop the customer from leaning against or climbing on the product, etc.
- To avoid electric shock and short circuit, do not allow customers to unplug the power plug without a justifiable reason.

⚠️ CAUTION

- Covers have been placed over parts on this product that the player could have their fingers or hands caught between, but this does not eliminate the danger to small children. Caution small children not to get close to the product while it is being played.
- Caution players not to take their feet off the footrests during play. If the player takes his or her feet off the footrests carelessly during play, their feet could get caught between or on parts, resulting in broken bones, sprains, or other injuries.
- Do not engage in actions that could result in accidents or trouble such as playing with bags or scarves draped around the neck or while holding drinks.
- Caution those other than the player that they should not go near the cabinet. Doing so could result in collision with the player or the motorcycle mechanism.
- Instruct players to grip the handles tightly during play to prevent accidents. Caution those that engage in risky behavior such as holding on with just one hand.
- Immediately stop such violent acts as hitting and kicking the product. Such violent acts can cause parts damage or cause the cabinet to fall over, resulting in injury.
- The maximum weight for players is 150 kg. Prohibit those who weigh more than 150 kg from playing as it could result in abnormal operation or damage to the parts.

4 PART DESCRIPTION

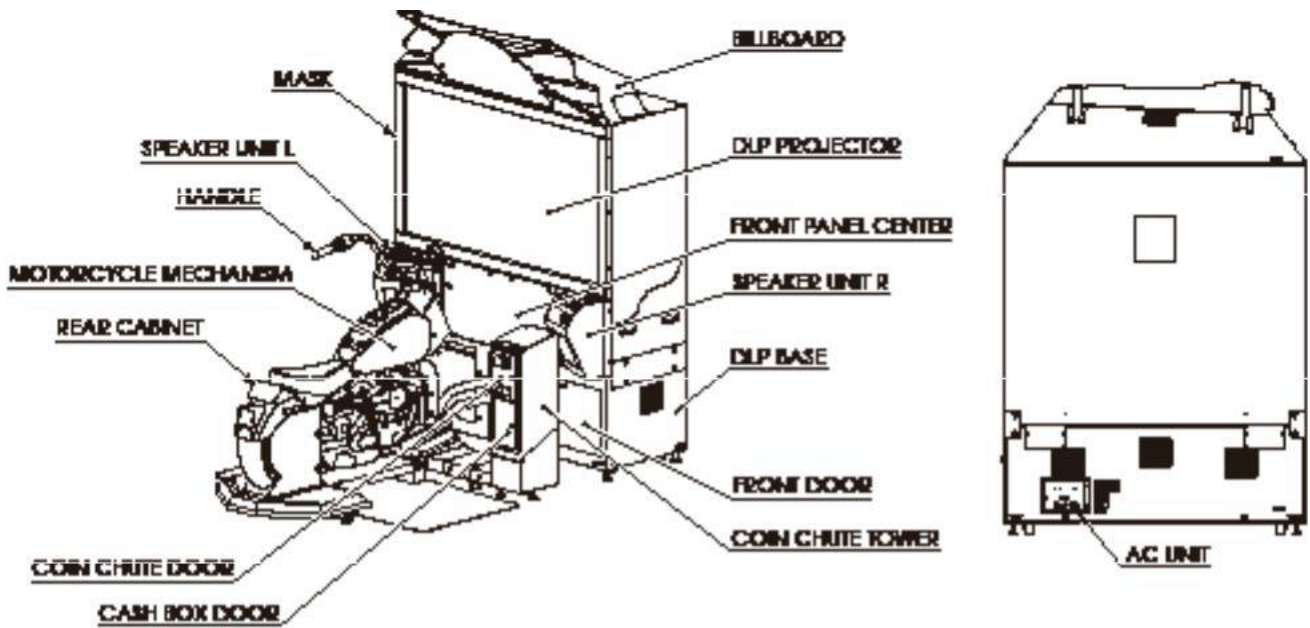

4 FIG. 01

4 Table 01 Major Dimensions and Weights for Reference When Moving the Product

ITEMS	Width x Depth x Height	Weight
Rear cabinet (without Coin Chute Tower)	35' x 59' x 51' 890 mm x 1,493 mm x 1,280 mm	314lbs 142 kg
DLP cabinet	54' x 24' x 74' 1,360mm x 610mm x 1,870mm	480lbs 218kg
Billboard	51' x 21' x 13' 1,270mm x 520mm x 320mm	40lbs 19kg

5 ACCESSORIES

Confirm that the accessories listed in the table below are present when setting up the product. The parts listed as “Spare” in the “Use etc.” column are expendable parts, and have therefore been included as spare parts.

5 TABLE 01 ACCESSORIES

DESCRIPTION: OWNER'S MANUAL
 Part No. (Qty.): 555-30-300(1)
 Note: This manual
 Figures:

Parts not labeled with part numbers are as yet unregistered or cannot be registered. Be sure to handle all parts with care, as some parts are not available for purchase separately.

DVD SOFT KIT (1)

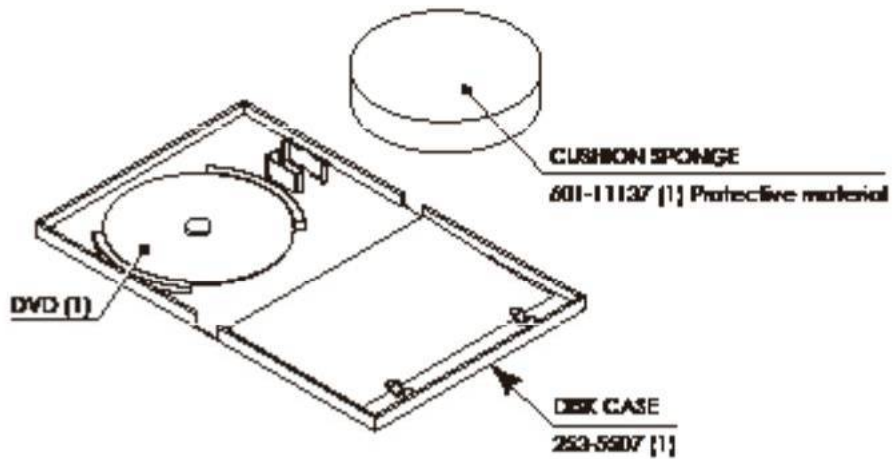

HEXAGON BOLT (2), black
 M6 x 20, w/spring washer, large flat washer used

GUIDE

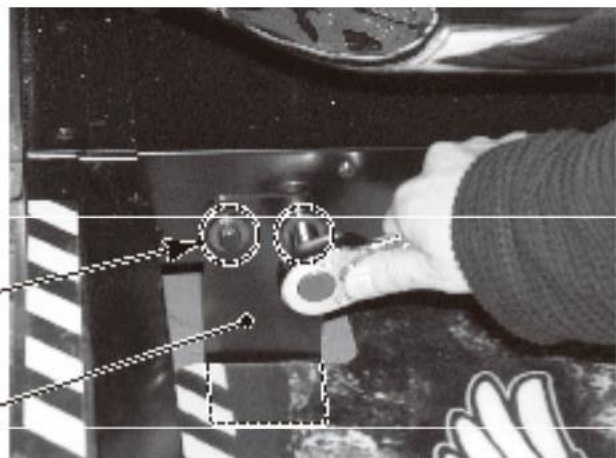

6 ASSEMBLY AND INSTALLATION

WARNING

- This work should be carried out by the site maintenance personnel or other qualified professionals. Work performed by non-technical personnel can cause a severe accident such as electric shock. Failing to comply with this instruction can cause a severe accident such as electric shock to the player during operation. If no one with proper technological expertise is available, request service from the office indicated in this document or the point of purchase so as to ensure safety.
- Perform assembly work by following the procedure herein stated. Failure to comply with the instructions can cause electric shock.
- Perform assembling as per this manual. Since this is a complex machine, incorrect assembling can cause an electric shock, machine damage and/or improper functioning as per specified performance.
- When assembling, be sure to use plural persons. Depending on the assembly work, there are some cases in which working by one person alone can cause personal injury or parts damage.
- Adhere strictly to all of the work procedures stipulated in this document. If two or more workers are working at the same time, exercise special caution. If sequences are carried out erroneously, accidents can result. There might also be cases in which the assembly cannot be completed.
- Pay special attention to the surroundings when a multiple number of workers are working at the same time. There is always the danger that a worker might be injured. In assembly and installation of this product, there are procedures in which a stepladder is used and procedures in which heavy objects are attached. Carelessness in doing work could lead to grave injuries and even fatalities.
- Ensure that connectors are accurately connected. Incomplete connections can cause electric shock.
- Be careful not to damage the wires. Damaged wires may cause electric shock or short circuit or present a risk of fire.
- Do not leave power cable or earth lines exposed over passageways. Exposure could lead to damage, electric shock or short circuit. Wherever wiring has been laid out on a floor surface, use a wiring protection cover. (Wiring diameter: Power cable, approx. $\varnothing 8$, Network cable, approx. $\varnothing 5$.)
- When inserting or removing a connector, always hold it by its main part. If you hold it by anything else while doing so, the connections between wire and connector terminal fixtures could be damaged; and there could be a short circuit or fire. There could also be poor connectivity.
- Make sure that all the adjusters are resting on the floor. The cabinet may move and cause an accident if the adjusters are not laid out properly.

⚠ WARNING

- Whenever any fasteners (e.g. screws, nuts) have been lost, always use replacement fasteners with proper dimensions as specified in this manual. If fasteners of any other dimensions are used, it could cause damage and/or separation of parts that result in secondary accidents.
- Exercise proper caution when using a step ladder to perform work. Falling or tipping over could result in a major accident. Also, if the ceiling is low, you could bump your head.

⚠ CAUTION

- To perform work safely and securely, be sure to prepare a step which is in a secure and stable condition. Performing work without using the step can cause accidents such as falling down.
- When attaching or removing doors be careful that your hand or finger does not get caught in anything.
- Support and hold parts in place securely and fasten them with screws and/or bolts. Use two workers, one to support the part and another to fasten it in place. If a part is not supported securely, it might fall down, resulting in an accident.
- Wear appropriate work clothing so that work can be performed safely. Use gloves and safety shoes to prevent accidents or injuries.
- When installing a wire protection cover over a floor, use a material shaped so that no one passing by will stumble over it. Using a material that could be stumbled over might lead to an accidental fall.
- Be careful in handling plastic parts. Be sure not to tighten screws or nuts too tightly. If such parts are exposed to excessive loads or impact, they might become damaged, resulting in fragments or cracks that could cause accidental injury.
- When installing 2 cabinets side by side, leave enough room so that the players will not collide with each other or other customers. If the cabinets are too close together, it could cause collisions. If the player were to fall off, it could result in a serious injury such as the player hitting his or her head on the other machine. It could also provoke unnecessary conflict between customers.

⚠ IMPORTANT

Be very careful when handling the DLP projector screen. The screen is easily damaged but cannot be repaired. If damaged the entire screen must be replaced.

The installation and assembly work for this product is performed according to the following procedures:

- 6-1 Attaching the Billboard
- 6-2 Attaching the Rear Cabinet
- 6-3 Fastening the Product to the Installation Location
- 6-4 Attaching the Coin Chute Tower
- 6-5 Installing the Mat
- 6-6 Connecting Power and Ground Wire
- 6-7 Checking the Assembly

Tools necessary for work

- MASTER KEYS

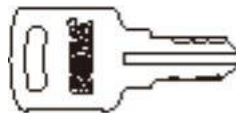

- Phillips screwdrivers (for M4, M5 screws)

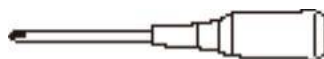

- Hexagonal screwdrivers (for M4 bolts and nuts)



- Socket wrenches (for M6, M8 bolts, nuts)

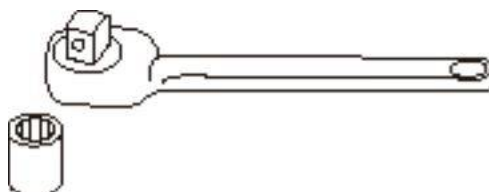

- Spanner with measuring distance of 24 mm to opposite side (for adjusters)

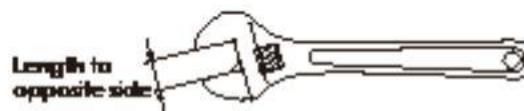

- Step/Stepladder

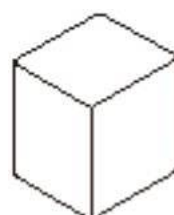

6-1 ATTACHING THE BILLBOARD

Use several stepladders to perform the above head work.

- 1 Unscrew 8 billboard screws on both sides.
Lift the billboard up with at least 1 other person and set it on the DLP projector from back.

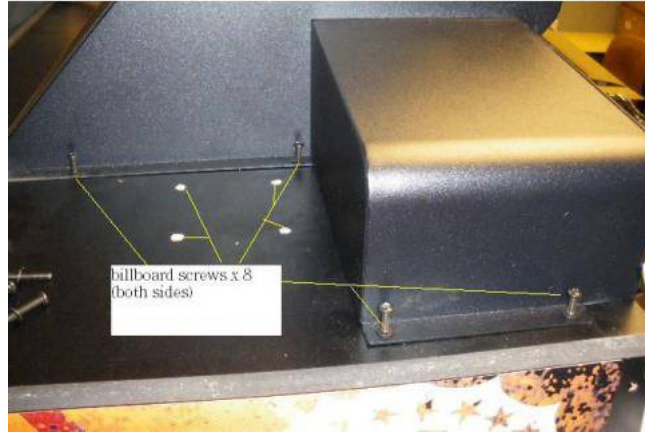

- 2 Fasten Billboard in place with 4 billboard screws on both sides.

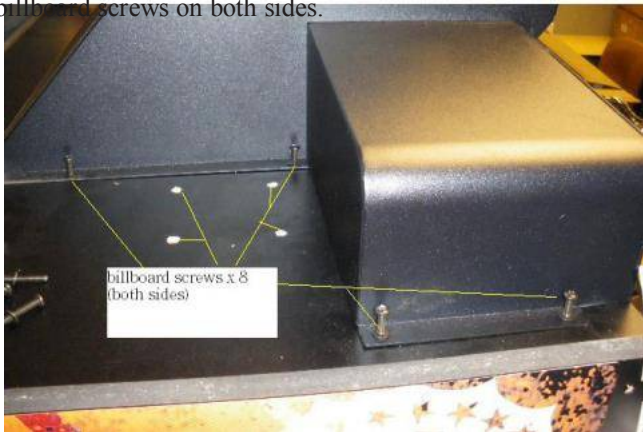

- 3 Insert billboard pipes into side of billboard. then fasten billboard pipes on both sides, using 4 billboard screws on both sides.

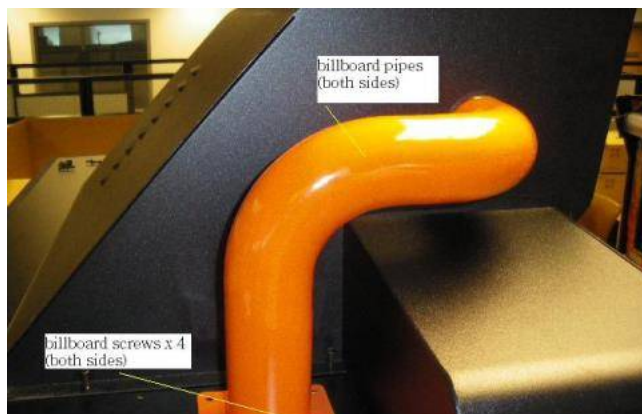

4

Connect 2 x 2pin connectors and 1 x 3pin connector, inside billboard.

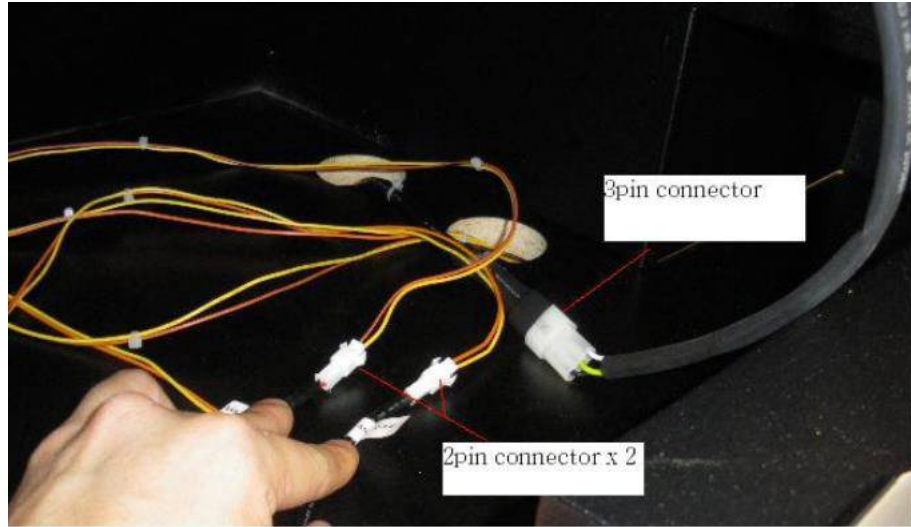

5

Place marquee, using 4 x marquee screws...



6-2 ATTACHING THE REAR CABINET

1

Connect the 5 connectors on the ASSY tube to the DLP base.

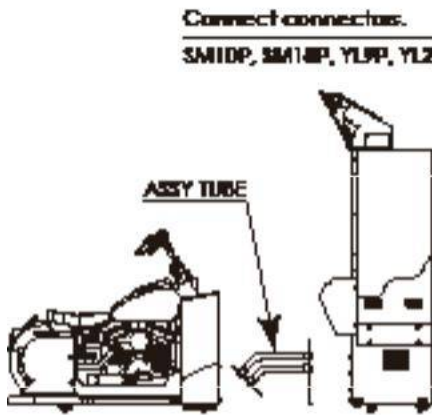

6-5 FIG. 01

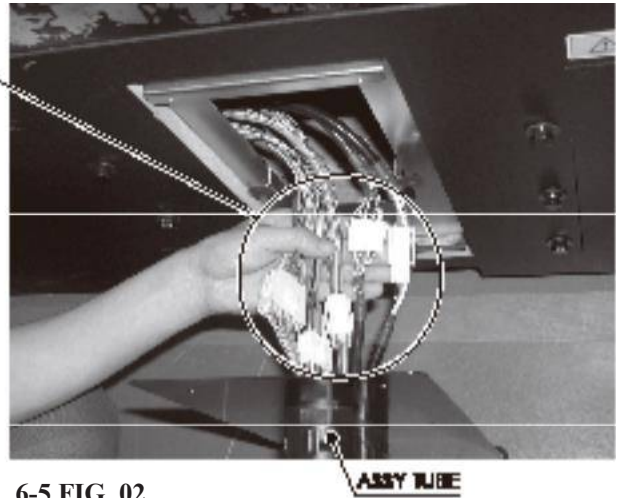

6-5 FIG. 02

2

Fasten the ASSY tube in place with 6 truss screws. Be careful not to pinch any wires.

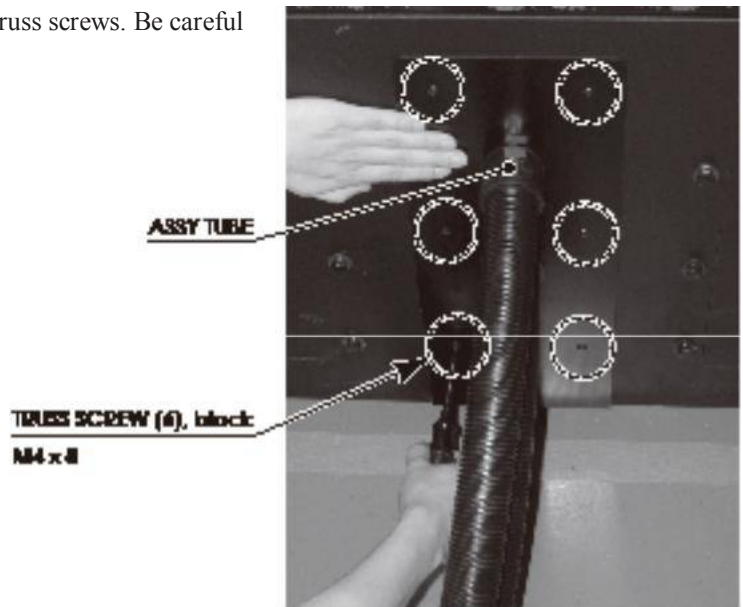

6-5 FIG. 03

3

Put the rear cabinet in place.

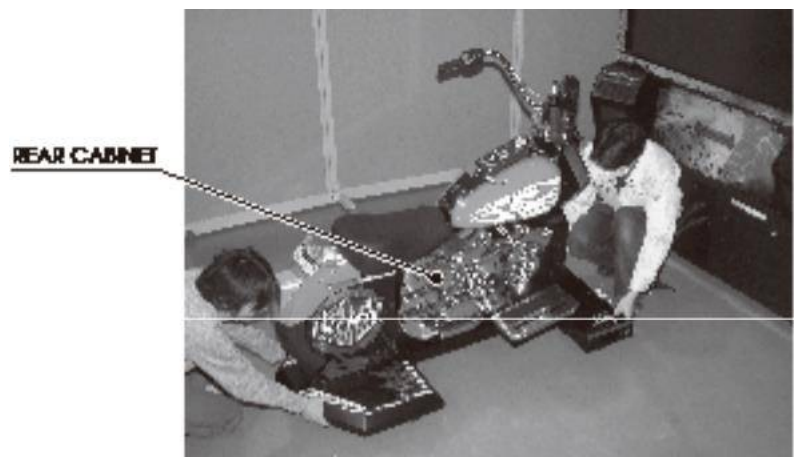

6-5 FIG. 04

4

Connect the 5 connectors to the rear cabinet. Be careful not to pinch any wires.

Connect connectors.
SM1DP, SM1BP, Y1SP, Y1Z1P, V1AP

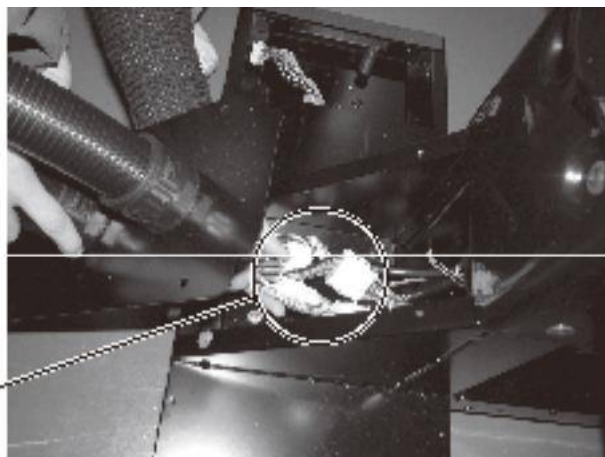

6-5 FIG. 05

5

Fasten the ASSY tube in place with 4 truss screws.

TRUSS SCREW (4), black
M4 x 8

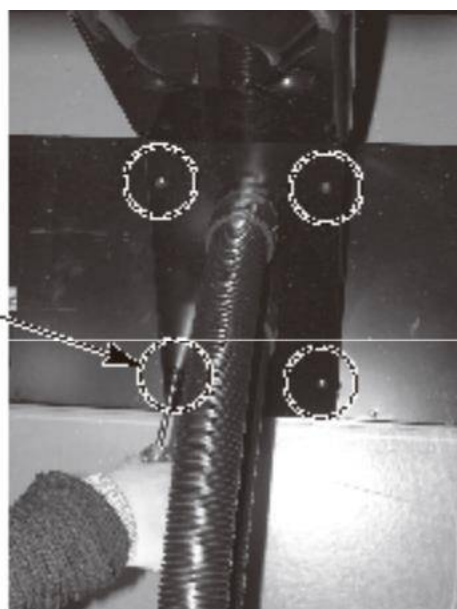

6-5 FIG. 06

6-3 FASTENING THE PRODUCT TO THE INSTALLATION LOCATION

⚠ WARNING

Make sure that all the adjusters contact the floor. Otherwise the cabinet could move, causing an accident.

This product has 9 casters and 11 adjusters. After determining the installation location, have the adjusters contact the floor directly, and adjust them so the machine will remain in a level position keeping a space of about 5 mm between the floor and the casters.

NOTE: Put the adjusters on the coin chute tower on the floor after following the instructions in “6-7 Attaching the Coin Chute Tower.”

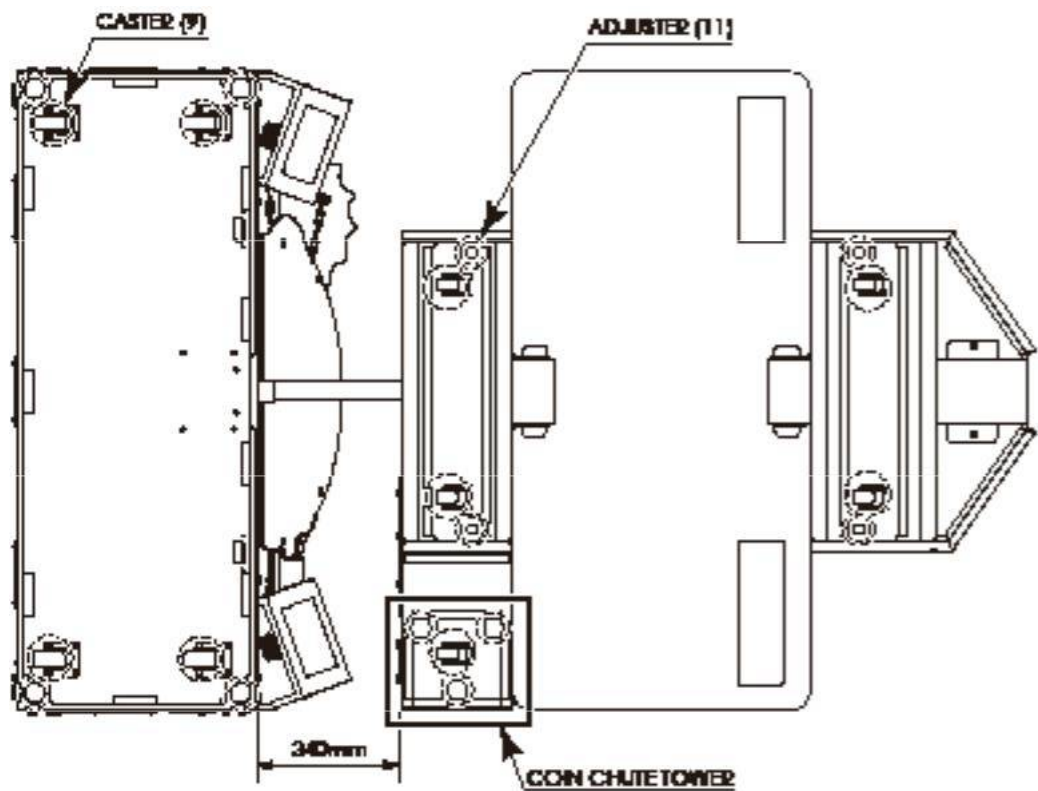

6-6 FIG. 01

- 1 Move the product to the installation site. Secure a 150 mm space between the back wall and the back of the cabinet for ventilation.
- 2 Leave 340 mm of space between the front and rear cabinets.
- 3 Bring the adjusters into direct contact with the floor. Use a wrench to align the height of the adjusters until the cabinet is perfectly level.

4

After setting, turn adjuster nuts upwards to tighten them and secure adjuster heights.

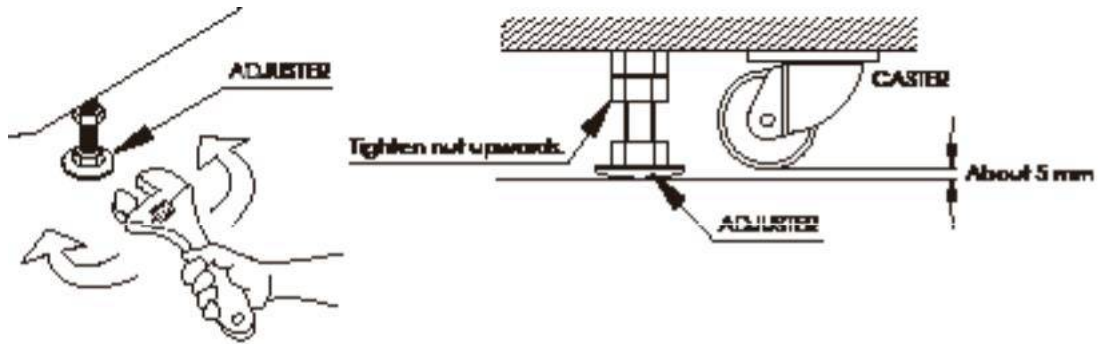

6-6 FIG. 02

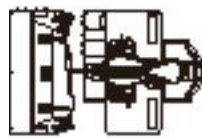

Views are reduced to 1/100.
Use them for reference in installation site layout.



6-6 FIG. 03

6-4 ATTACHING THE COIN CHUTE TOWER

- 1 Fasten the hole lid in place with 4 screws. Make sure the rectangular hole on the hole lid is in the position shown in the figure when attaching it.

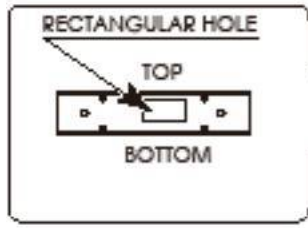

SCREW [4]
M4 x 6, w/flat 8. spring washers

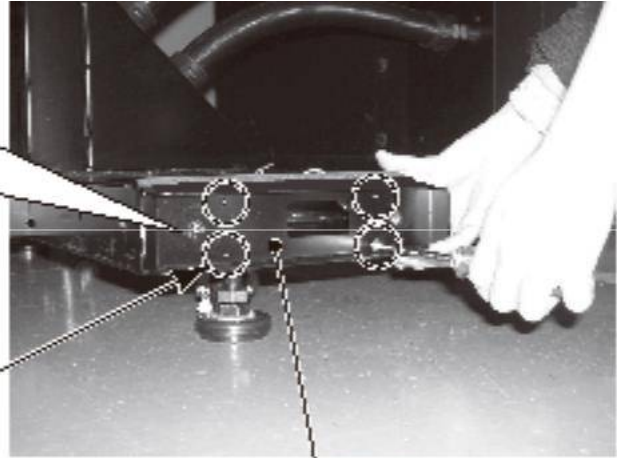

6-7 FIG. 01

HOLE LID

- 2 Attach 2 rubber dampers to the cabinet.



6-7 FIG. 02

RUBBER DAMPER [2]

- 3 Insert the tower joints into the rubber dampers and fasten them in place with 2 nuts.

NUT [2]
M8, large flat 8. spring washers used

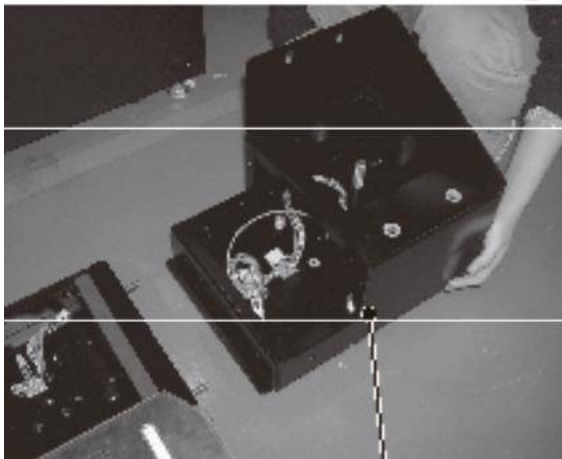

6-7 FIG. 03

TOWER JOINT



6-7 FIG. 04

4 Attach the wire

cover.

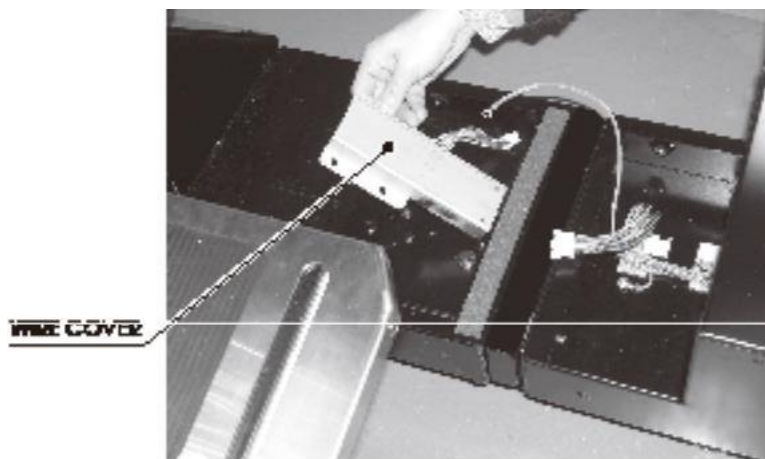

6-7 FIG. 05

5 Put the ground terminal and connector through the wire cover.

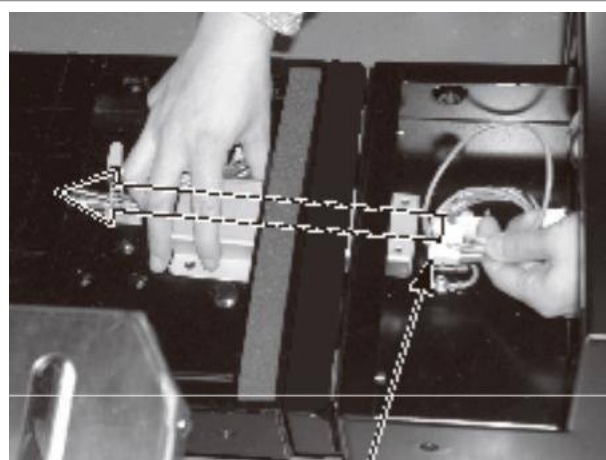

6-7 FIG. 06

6 Fasten the ground terminal in place with 1 screw.

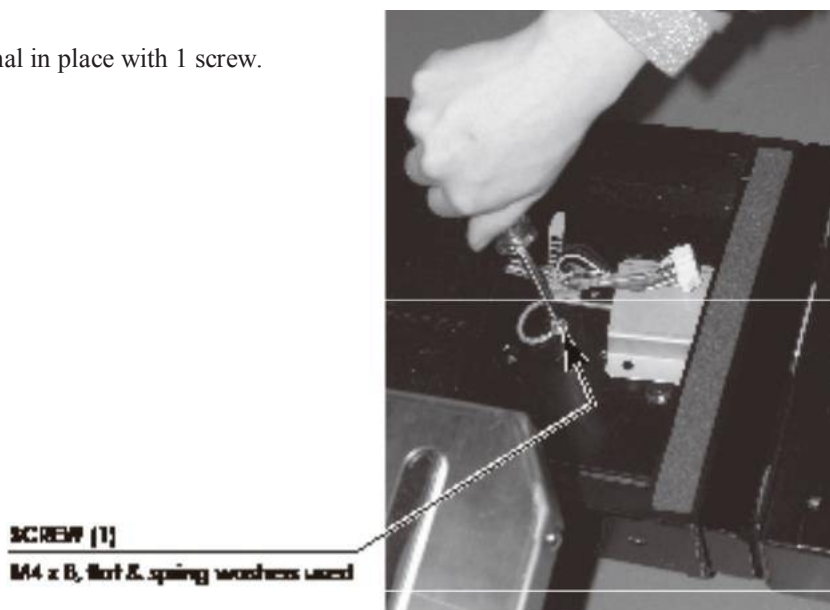

6-7 FIG. 07

7 Connect the connector.

Connect connector.
SMTBP

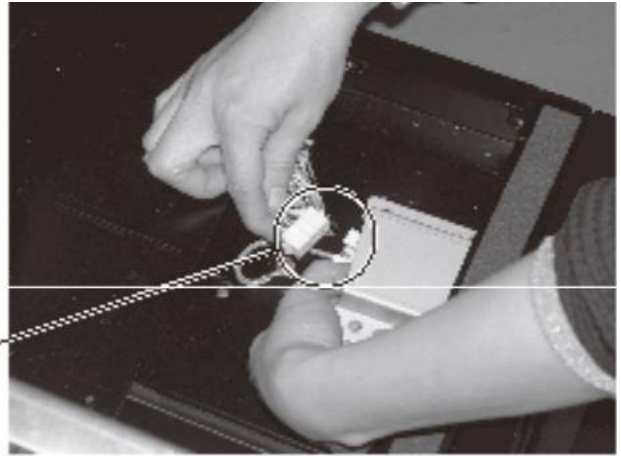

6-7 FIG. 08

8 Fasten the duct stay to the wire cover with 2 screws. Attach the duct stay as shown in the figure.

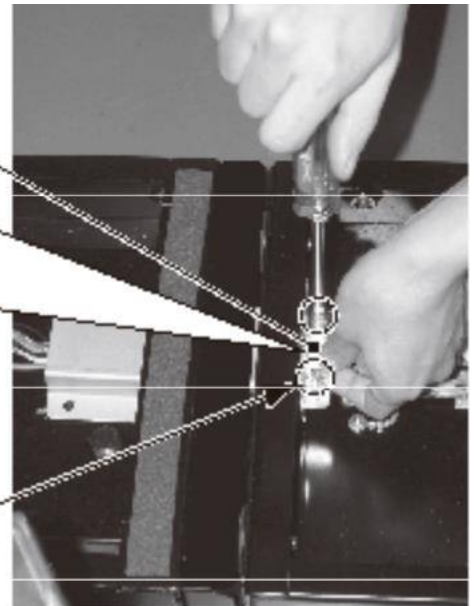
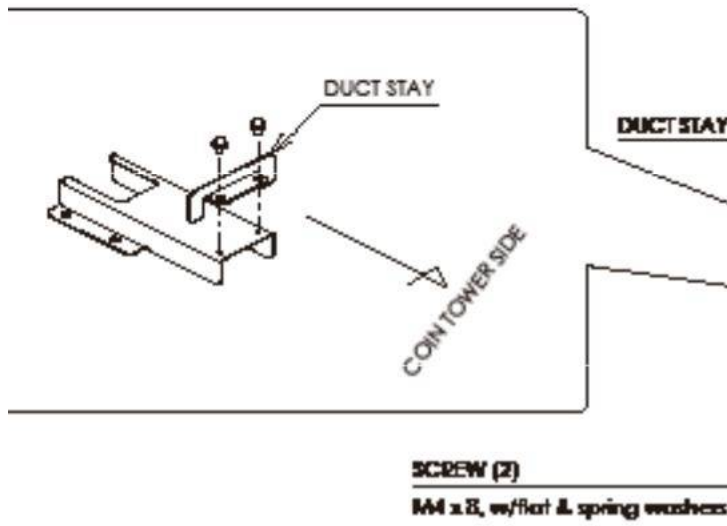

6-7 FIG. 09

9 Fasten the wire cover in place with 4 screws. Be careful not to pinch any wires.

SCREW (4)
M4 x 8, w/flat & spring washers

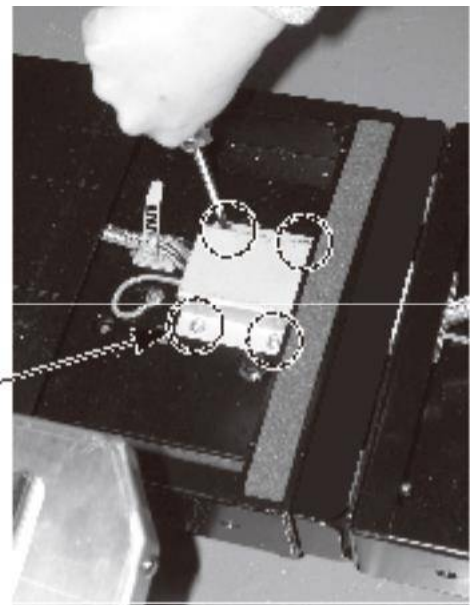

6-7 FIG. 10

10 Fasten the base cover in place with 4 hexagon bolts.

HEXAGON BOLT (4), black
M6 x 20, w/spring washer, large flat washer used

BASE COVER

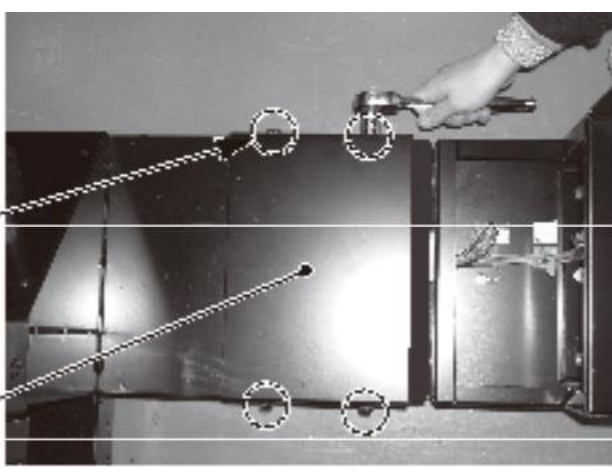

6-7 FIG. 11

11 Attach and fasten the joint lid in place with 2 truss screws and 2 hexagon bolts.

TRUSS SCREW (2), black
M4 x 8

JOINT LID

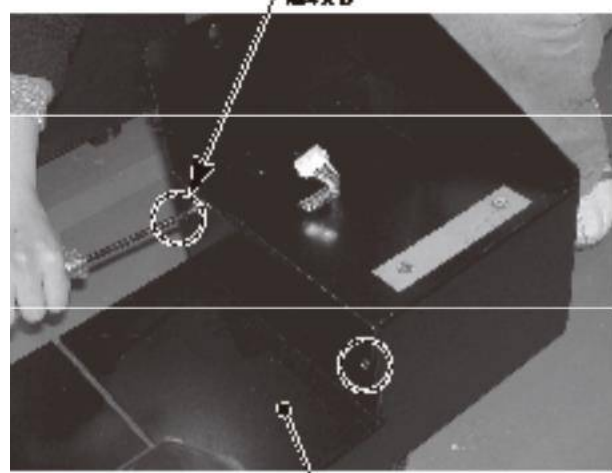

6-7 FIG. 12

HEXAGON BOLT (2), black
M6 x 20, w/spring washer, large flat washer used

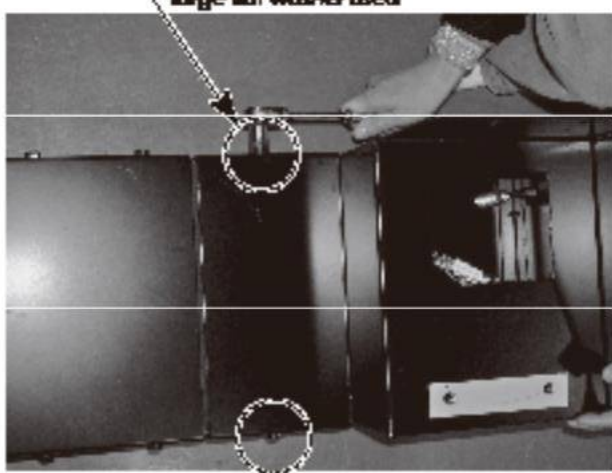

6-7 FIG. 13

12 Hold the coin chute tower up with at least 1 other person and attach it after connecting 1 connector. Be careful not to pinch any wires.

Connect connector.
STEP

COIN CHUTE TOWER

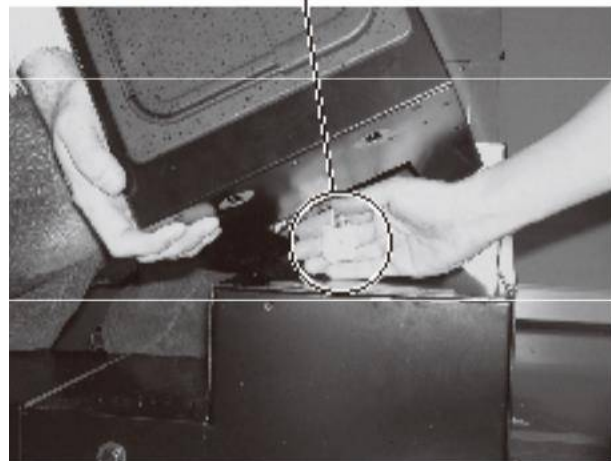

6-7 FIG. 14



6-7 FIG. 15

13 Unlock the coin chute door with the master key and take out the key inside. Unlock the cash box door with the key and open it.

14 Fasten the coin chute tower in place with 4 hexagon bolts.



6-7 FIG. 16 Inside cash box door

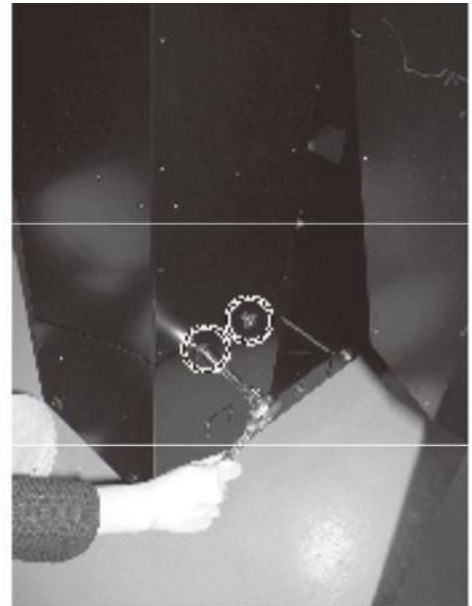

6-7 FIG. 17 DLP projector side

15 Place the coin chute tower's 3 adjusters on the floor. (See "6-6 Fastening the Product to the Installation Location.")

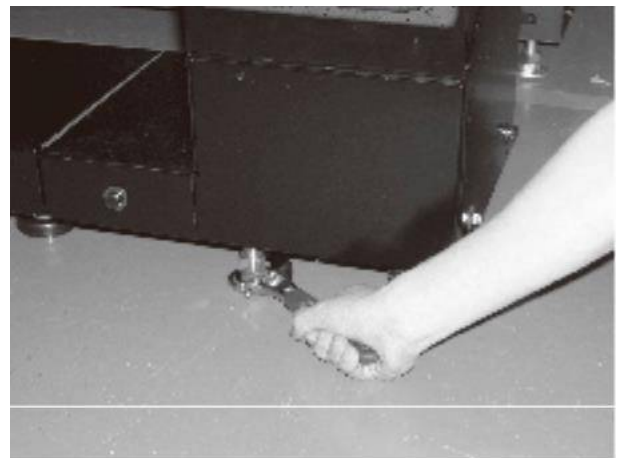

6-7 FIG. 18

NOTE: The coin chute tower is designed to move in each direction even after being attached in order to prevent vibration.

6-5 INSTALLING THE MAT

- 1 Lay the mat down.



6-8 FIG. 01

- 2 Fasten 2 guides to the right side of the rear cabinet with 2 hexagon bolts in the front and back.

HEXAGON BOLT (2), black:
M6 x 20, w/spacing washer, large flat washer used

GUIDE

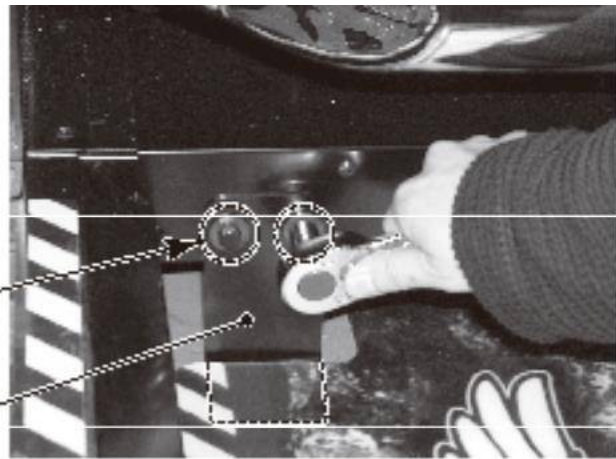

6-8 FIG. 02 Right side of rear cabinet (rear)

- 3 Refer to Step 2 and fasten 2 guides to the left side of the rear cabinet with 2 hexagon bolts in the front and back.

- 4 If the floor is bare, adjust the position of the mat and attach the three pieces of double-sided tape on both sides of the mat to stick it to the floor.
If the floor is carpeted, adjust the position of the mat and attach the supplied velcro to the three pieces of double-sided tape attached on both sides of the mat to stick it to the floor.

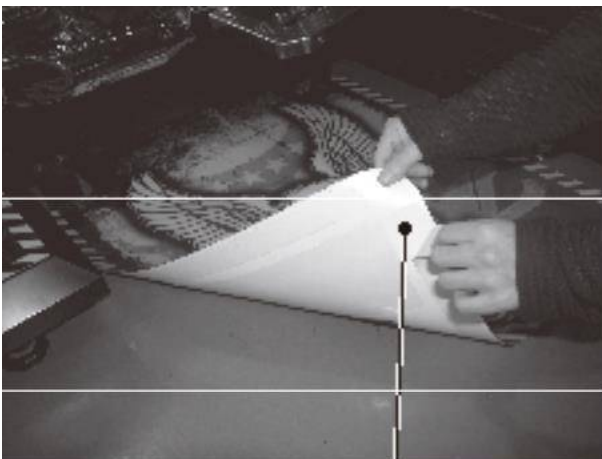

6-8 FIG. 03



6-8 FIG. 04

6-6 CONNECTION OF POWER AND GROUND WIRE

⚠ WARNING

- Use the power supply equipped with an earth leakage breaker. Use of power supply without such a breaker could result in fire if there is a current leakage.
- Have available a securely grounded indoor ground terminal. Without proper grounding, customers could be electrocuted and product operations might not always be stable.
- Do not expose the power cord or ground wire. If these are exposed, customers could stumble over them, for instance, and easily damage them. Additionally, if these lines are damaged, there could be a risk of electrical shock or short circuit. Set these lines at locations where they will not interfere with customer traffic, or attach covers to them.
- After laying out the power cord on the floor, be sure to always protect it. If the power cord is left exposed, it can easily be damaged, resulting in electrical shock.
- When using the product's AC unit ground terminal, use ground wire with a circular terminal as shown in the illustration, and establish ground securely. Avoid indiscriminant grounding operations such as use of wire with only its sheath peeled off.

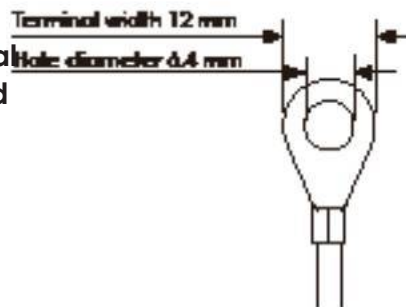

CP IMPORTANT

If grounding has been established with the ground wire inside the power cord, do not perform grounding with the AC unit ground terminal. Conversely, if the AC unit ground terminal has been used for grounding, do not establish ground with the ground wire in the power cord. Otherwise there could be faulty or erroneous operations.

The AC Unit has Main SW, Circuit Protector, Earth Terminal and the Inlet which connects the Power Cord.

1

Ensure that the Main SW is OFF.

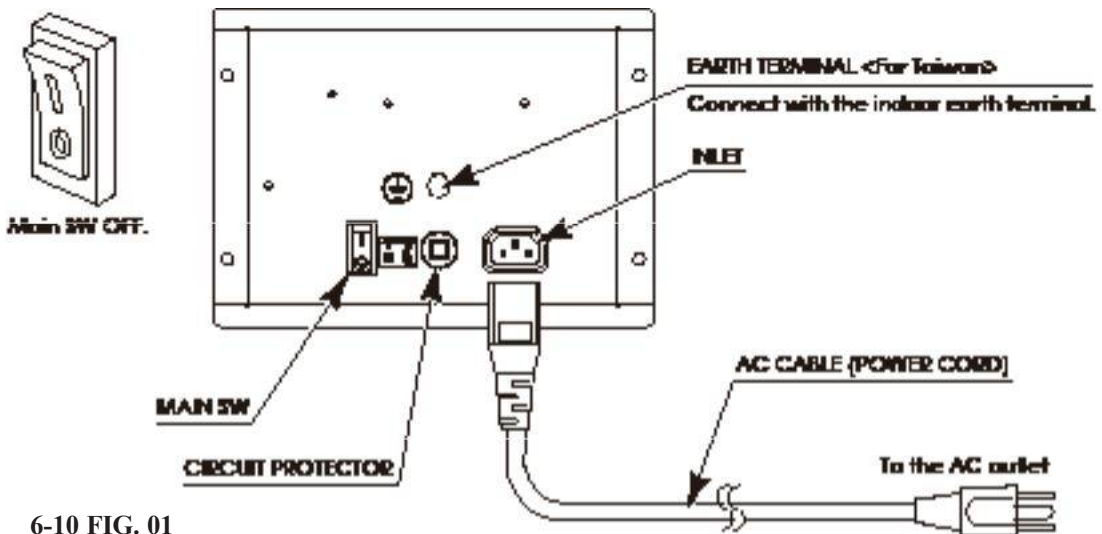

6-10 FIG. 01

2

Connect one end of the earth wire to the AC earth terminal, and the other end to the indoor earth terminal.

The accessory power cord contains earth wire. Connect power cord to AC unit inlet, and then insert power cord plug into "power outlet with earth terminal". If there is no "power outlet with earth terminal", be sure to always establish grounding by some means; for example, by connecting the AC unit earth terminal to the earth system with an earth wire set

aside for that purpose. When using a conversion adapter sold on the market to provide power, connect the adaptor's earth wire terminal to an "earth terminal that is securely grounded".

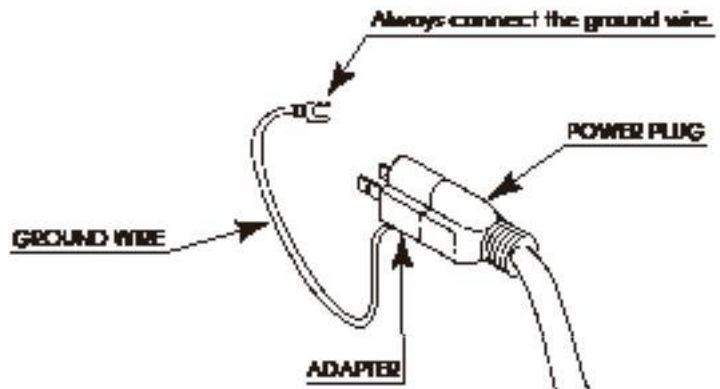

6-10 FIG. 02

3

When using an earth wire set aside separately, connect one end of the earth wire to AC unit earth terminal and the opposite end to indoor earth terminal. The AC unit earth terminal uses a bolt and nut combination. Remove the nut, pass the earth terminal through the bolt, and then tighten the nut.

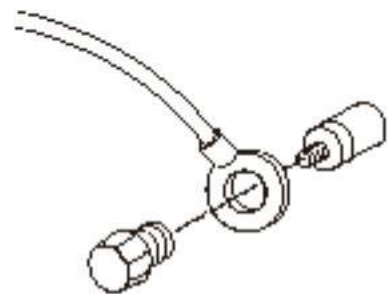

6-10 FIG. 03 <For Taiwan>

4

Lay out power cord indoors. Attach power cord cover to protect the cord. If grounding is established by using an earth wire set aside separately, lay out this earth wire and protect it at the same time.

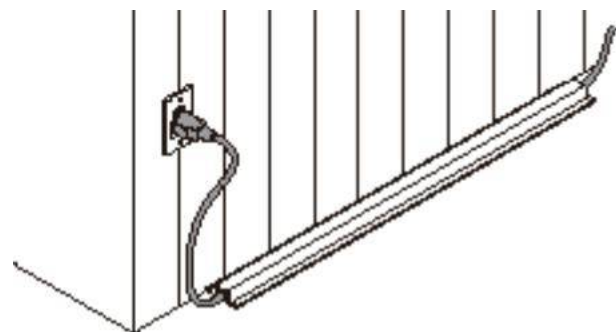

6-10 FIG. 04

6-7 CHECKING THE ASSEMBLY

Refer to Chapter 9 “Explanation of Test and Data Display” and enter Test Mode.

Use Test Mode to check whether or not the product has been assembled correctly and whether or not everything is normal with the LINDBERGH RED EX, connected boards, and input/output devices.

(1) MONITOR TEST

A screen for testing the monitor is displayed when MONITOR TEST is selected on the System Test Menu Screen in System Test Mode. The monitor is adjusted before it is shipped from the factory, but look at the test screen to see if further adjustment is necessary. If further adjustment is necessary, refer to Chapter 13 and adjust the monitor.

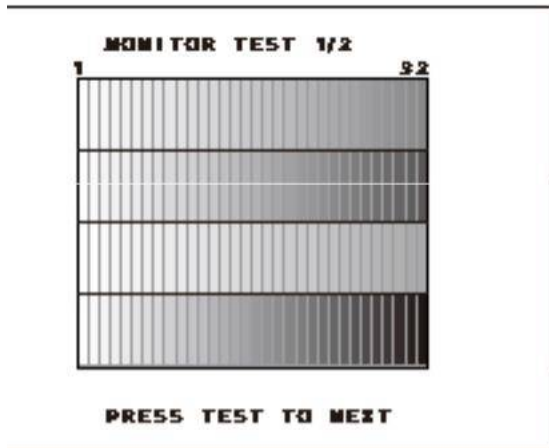

6-12 FIG. 01

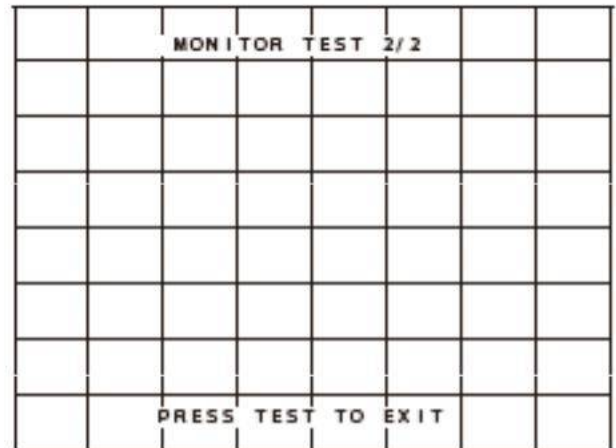

6-12 FIG. 02

(2) SPEAKER TEST

A screen for testing the speakers is displayed when SPEAKER TEST (PCI) is selected on the System Test Menu Screen in System Test Mode. A sound test can be performed by turning the RIGHT SPEAKER or LEFT SPEAKER “ON” and “OFF.”

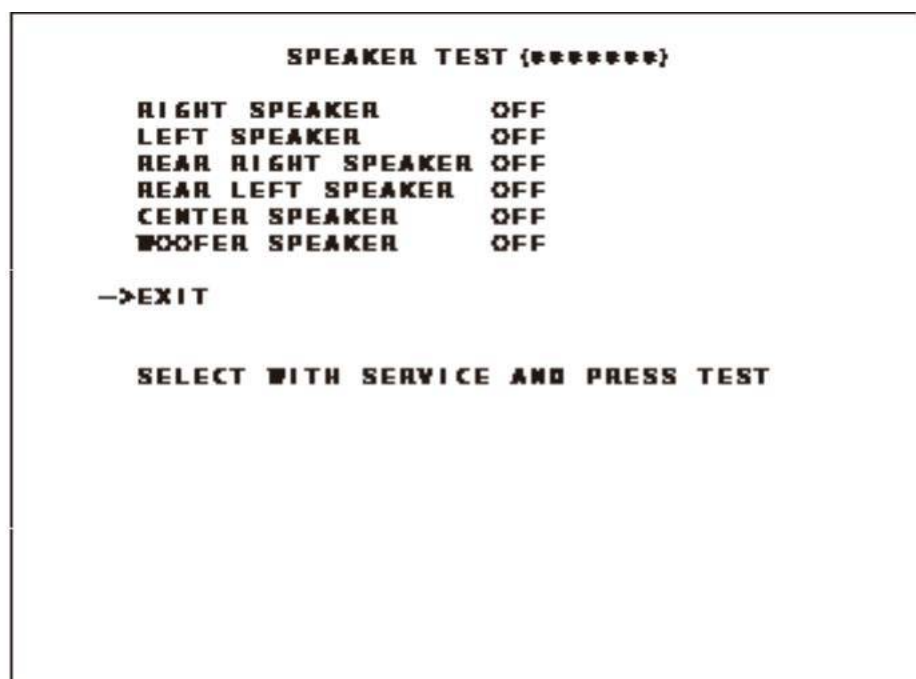

6-12 FIG. 03

(3) INPUT TEST

A screen for testing the switches is displayed when INPUT TEST is selected on the GAME TEST MODE Screen in Game Test Mode.

Refer to “9-3-2 INPUT TEST” and check to make sure it works correctly.

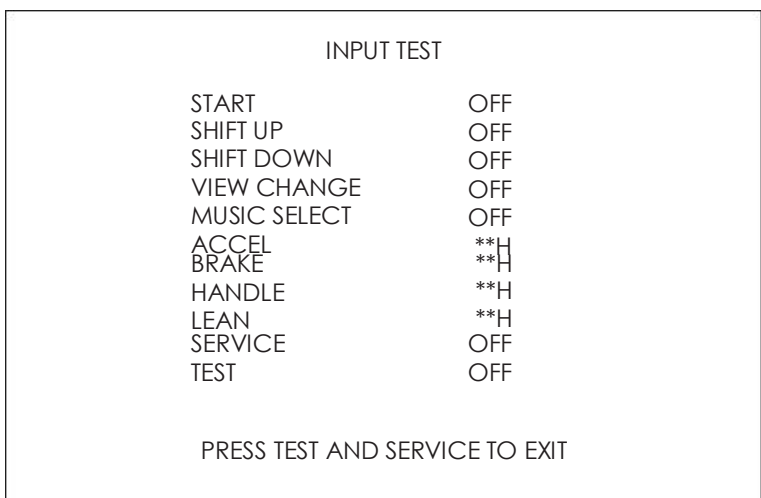

6-12 FIG. 04 INPUT TEST SCREEN

(4) OUTPUT TEST

A screen for testing the lamp and wire connections is displayed when OUTPUT TEST is selected on the GAME TEST MODE Screen in Game Test Mode. Refer to “9-3-3 OUTPUT TEST” and check to make sure the lamps light up properly and that the motorcycle mechanism is working correctly.

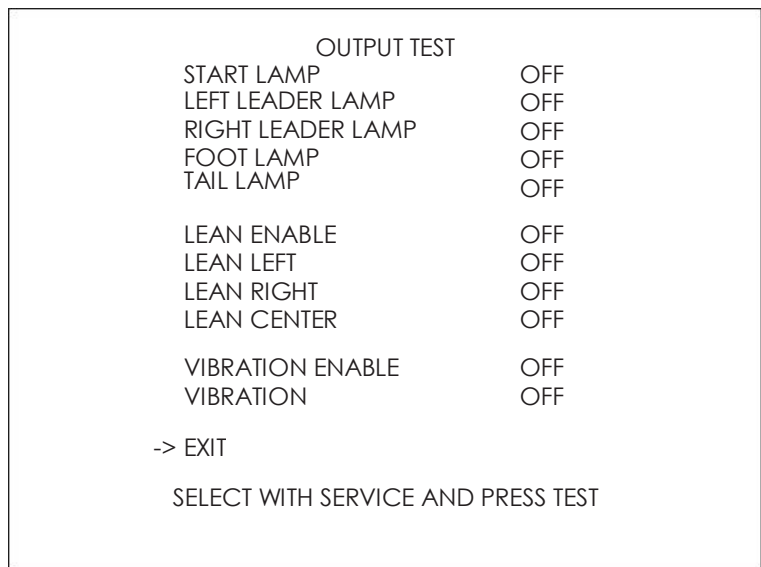

6-12 FIG. 05 OUTPUT TEST SCREEN

(5) INPUT ADJUSTMENT

A screen for adjusting the controller is displayed when INPUT ADJUSTMENT is selected on the GAME TEST MODE Screen in Game Test Mode. Before making the game available for play, always test the game and check to make sure no adjustments are necessary and that it is functioning correctly. (See 9-3-5.)

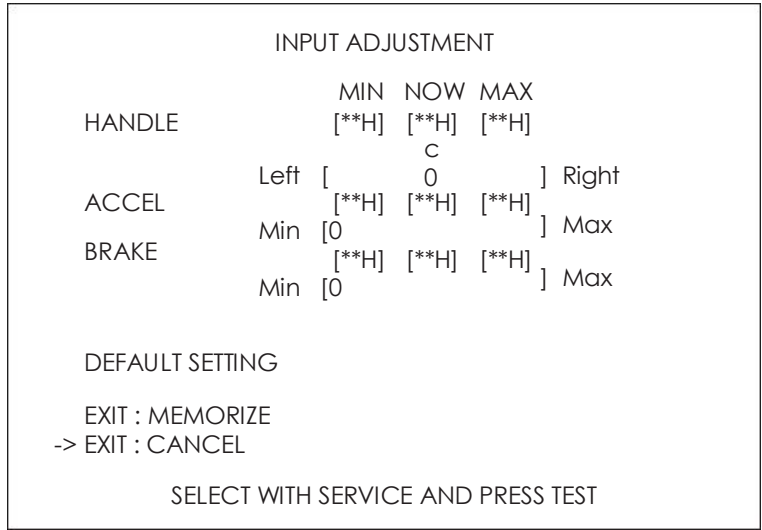

6-12 FIG. 06 INPUT ADJUSTMENT SCREEN

7 PRECAUTIONS WHEN MOVING THE MACHINE

WARNING

- When moving the machine, be sure to pull out the plug from the power supply. Moving the machine with the plug still inserted can cause the power cord to be damaged, resulting in a fire and/or electric shock.
- When moving the machine on the floor, retract the adjusters, and ensure that the casters make contact with the floor. Pay careful attention so that the casters do not run over power cords and earth wires. Damaging the power cords can cause an electric shock and/or short circuit.
- When lifting the cabinet, be sure to hold the handles and the bottom part. Lifting the cabinet by holding other portions may damage parts and installation portions due to the empty weight of the cabinet, and may cause personal injury.
- When moving the DLP projector, do not push it from the rear side. Push it from sideways. Pushing the DLP projector from the rear side can have the DLP projector fall down, causing personal injury, etc. In case the floor has slanted surfaces or step-like differences, be sure to move the machine by 2 or more persons.

CAUTION

Do not hold or press the plastic parts when moving the machine. Failure to observe this instruction may break the parts, and eventually the broken pieces may cause a personal injury.

IMPORTANT

- Disassemble the product into the individual units before moving it. If the product is tilted or the cabinet is set on an uneven surface in an assembled state, the joints could break.
- Do not allow ropes to come in contact with the surface of the machine directly or they may scratch it. Put some kind of protective material under the rope where it will touch the machine.

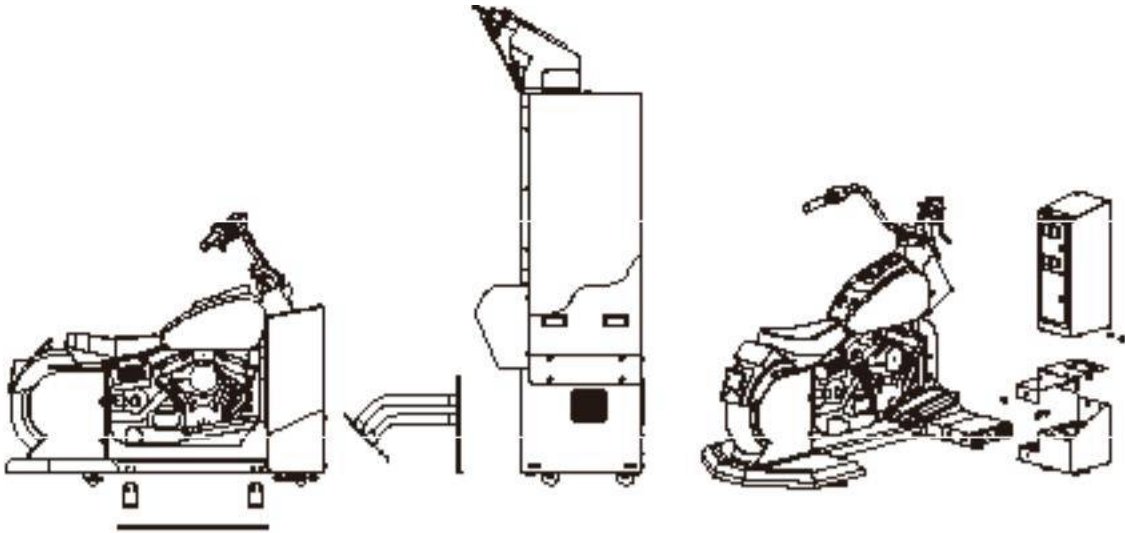

7 FIG. 01

Remove the mat and DVD DRIVE when moving the product and separate the rear cabinet. (See Chapter 6.)
 If there is a difference in floor level of 1 cm or more, add a ramp or separate the coin chute tower as well.

Do not push the product holding the shaded areas.

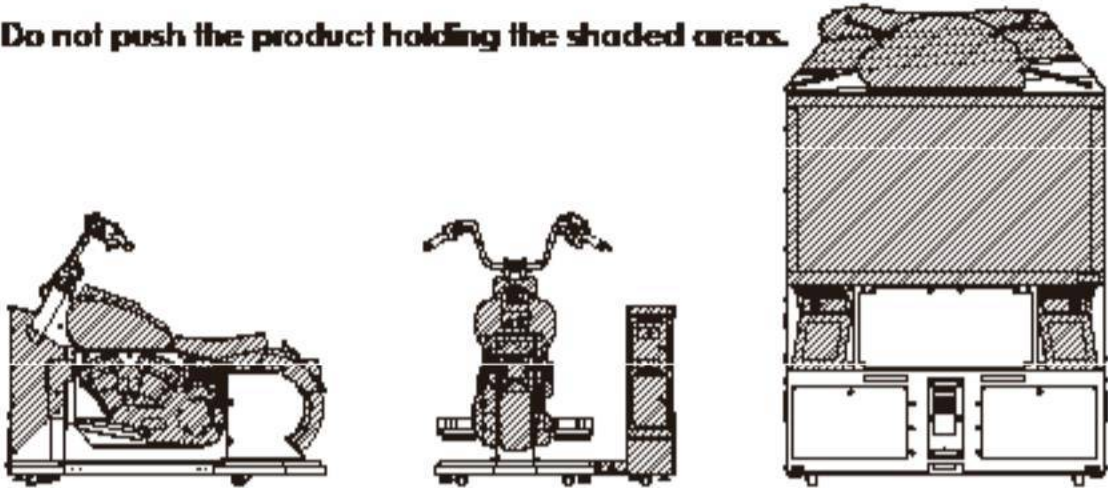

7 FIG. 02

The product can be moved with the coin chute tower attached, but do not pull or push on it in order to move the cabinet.

8 GAME DESCRIPTION

8-1 HOW TO PLAY

1 When you insert coins, they will be counted in the credit display at the bottom of the screen. When you insert enough coins for a game, the message at the bottom will change from “INSERT COIN (S)” to “PRESS START BUTTON,” and the START button will flash.

Up to 24 credits can be counted at once. Coins inserted after 24 credits are recorded will not be counted or returned. However, the number of coins inserted will be counted in the data display and the coin meter.

NOTE: The credit and coin settings can be configured under COIN ASSIGNMENTS in System Test Mode. (See 9-2.)

2 Once you press the START button when the START button is flashing, the game will begin.

3 The modes that can be played after the game starts differ depending on whether or not it has been configured for network play. (See Chapter 18 “Network Play.”)

- Not configured for network play: Single-player Story Mode (see 8-2) only.
- Configured for network play: Select between Single-player Story Mode and Multiple-player Versus Mode (see 8-3).

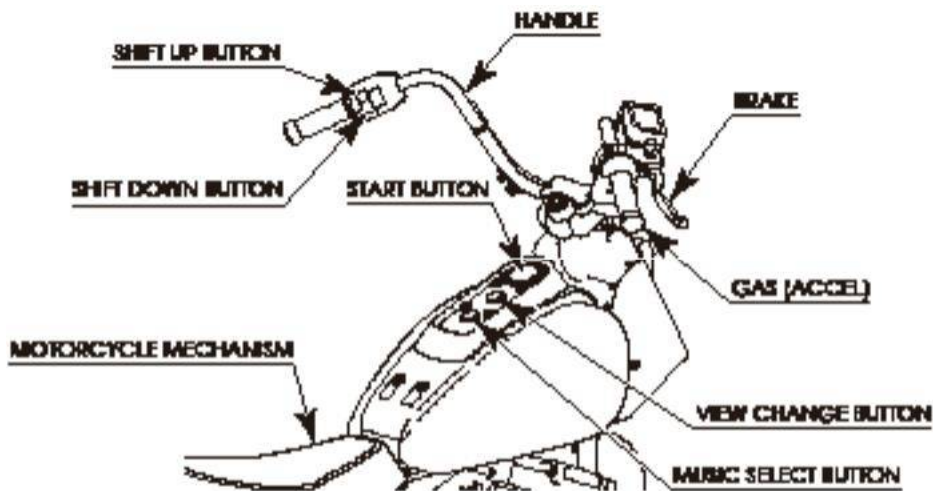

8-1 FIG. 01 Button Positions

8-2 STORY MODE

In story mode, you play against distinctive rivals that appear during the rounds. If you cross the finish line before your rival within the allotted time, you will be able to proceed to the next round. If you are unable to cross the finish line first or within the allotted time, you can proceed to the next round by continuing. In the final round, you will compete against the “Reigning King,” the ultimate rival. If you beat him, you will become the new “Reigning King” and your name will be displayed during the advertisements.

NOTE: If the game is not configured for network play, Story Mode will begin after the game starts.

If the game is configured for network play and there are no entries from the other cabinets, you will be able to play in Story Mode after the game starts.

- 1 You will be taken to the Motorcycle Selection Screen.
Select 1 motorcycle from the many available. Each motorcycle has its own features, so select one that suits you.

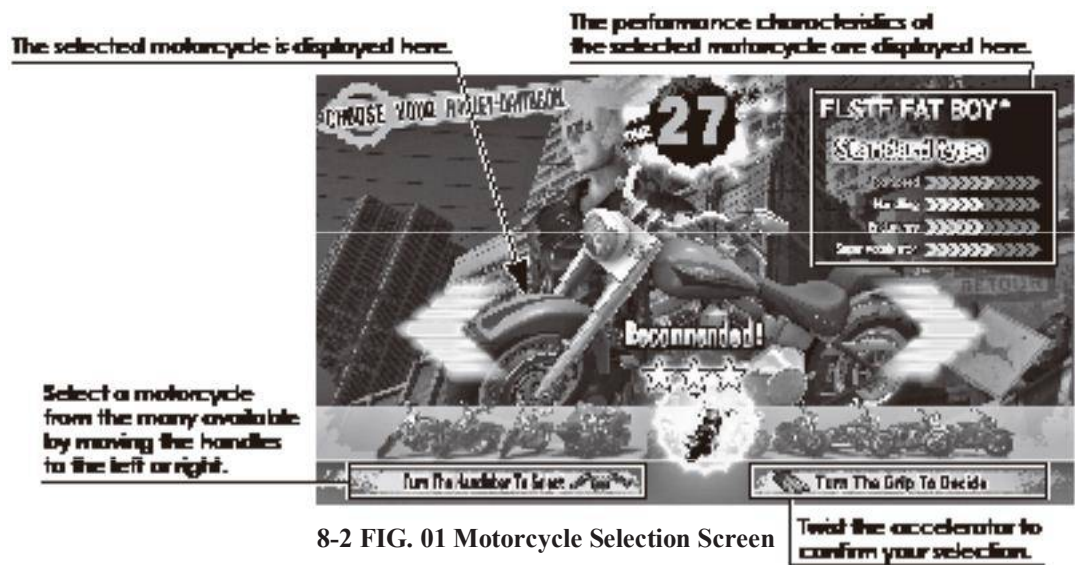

8-2 FIG. 01 Motorcycle Selection Screen

- 2 After selecting your motorcycle, you will be taken to the Music Selection Screen.
Select 1 song from the many available. The selected song will be played during the game to enliven the mood. The song can also be changed during the game by pressing the Music Select Button.



8-2 FIG. 02 Music Selection Screen

- 3** After selecting music, several cut scenes will follow and you will be taken to the Game Play Screen. In Story Mode, you will be able to proceed to the next round if you overtake your rival and cross the finish line first.

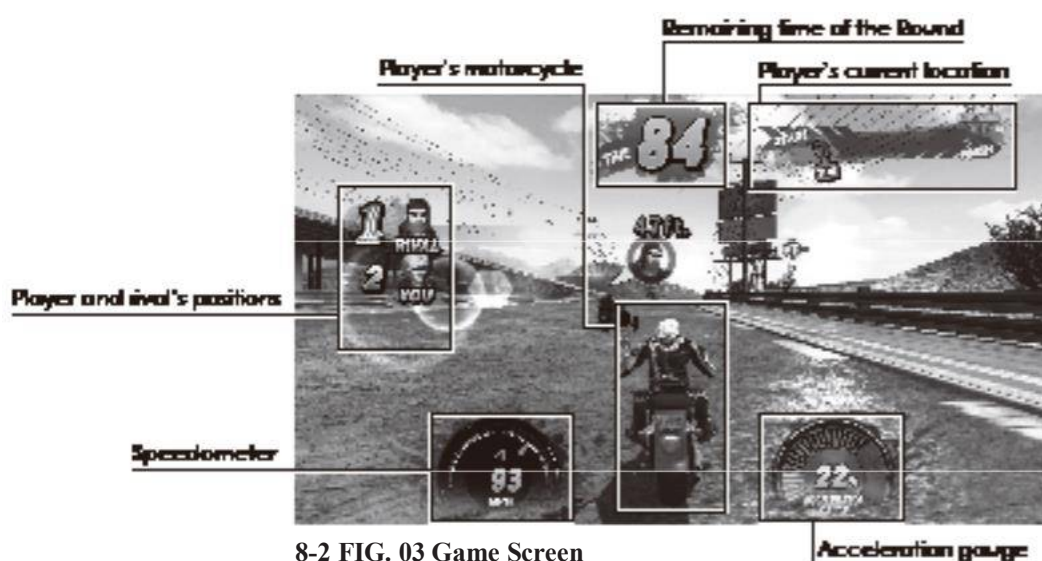

8-2 FIG. 03 Game Screen

The player can perform the following operations during the game:

How to Operate the Motorcycle

Twist the accelerator:

The motorcycle will speed up in proportion to how far the accelerator on the right side of the handle is twisted.

Twist the accelerator twice rapidly:

If the acceleration gauge has filled and the accelerator is twisted twice rapidly, the motorcycle's accelerating power will increase in proportion to how full the gauge is, and it will speed up. Also, if the acceleration gauge is completely full when the accelerator is twisted twice rapidly, the motorcycle's accelerating power will increase even more than normal and can be used for an extended period of time. Additionally, the acceleration gauge will fill up as items are collected.

Tilt the handle:

The motorcycle will turn in the direction the handles are tilted.

Pull the brake lever:

The motorcycle will slow down in proportion to how hard the brake lever on the right side of the handle is pulled.

Push the up/down shift buttons:

If the shift buttons on the left side of the handle are pressed, the motorcycle will switch from automatic to manual, and the gears can be shifted up and down by pressing the up and down shift buttons, respectively. If the buttons are not pressed for a certain period of time, it will automatically switch to automatic.

How to Perform Other Operations

MUSIC SELECT BUTTON:

The current song can be changed by pressing the Music Select Button. Press it to select another song from the many available.

VIEW CHANGE BUTTON:

Switch between 3 different views.

- 4** If you were unable to cross the finish line within the allotted time or could not overtake your rival, the Continue Screen will appear after the round ends. If you wish to CONTINUE, insert the required number of coins and press the START button again. If there are enough credits remaining to CONTINUE, you can join again by pressing the START button.

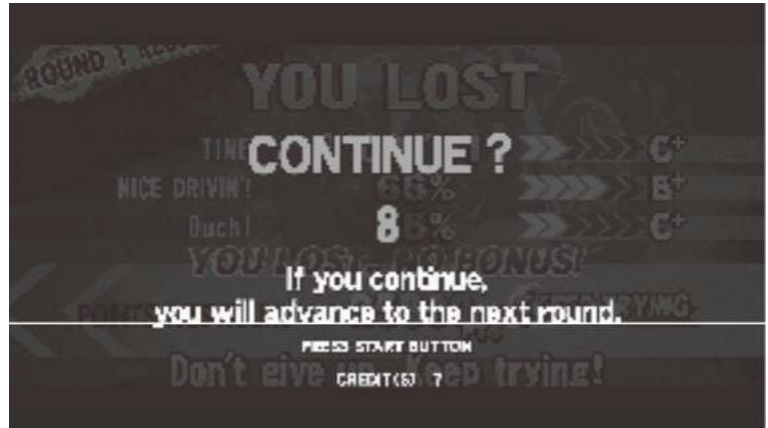

8-2 FIG. 04 Continue Screen

- 5** If you choose to continue, game play will resume on the next round after you select a motorcycle and music. If you continue on the final round, game play will resume on the final round again.
- 6** If you proceed to the next round, you will be taken to the Course Selection Screen to select the next course. If you are on either the first or the final round, however, you will not be able to select a course.

Select the course you wish to compete in from the 2 available and proceed to the next round.

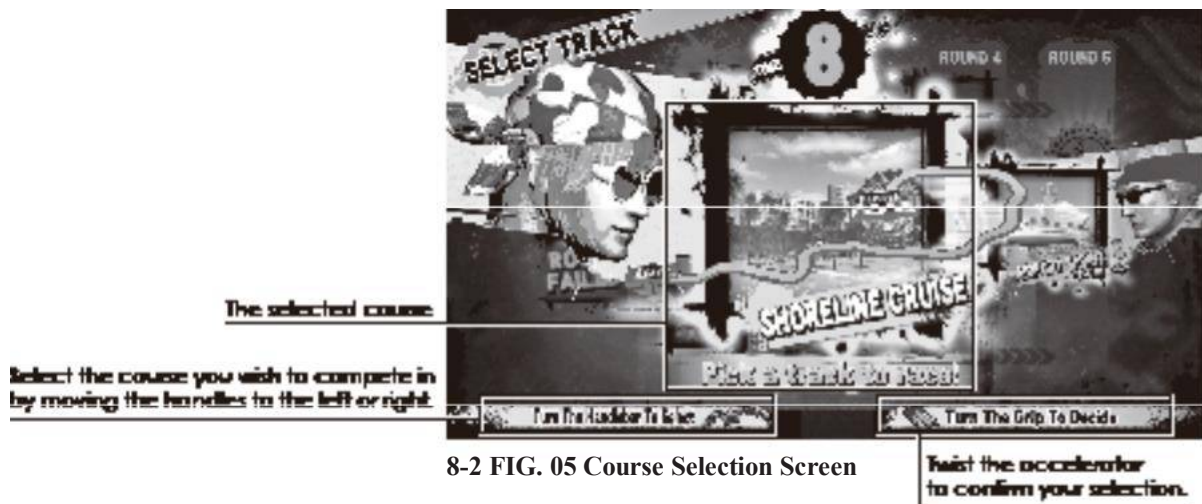

8-2 FIG. 05 Course Selection Screen

- 7** In each round, you will compete with a distinctive rival. If you beat the “Reigning King,” the rival in the final round, you will be able to enter your name and it will be displayed during the advertisements as the Reigning King. Also, if your total points after the final round are within the top 20 among the previous Reigning Kings, your name will be displayed in the rankings as well.
- NOTE: The “Current King” is the player most recently registered as a “Reigning King,” regardless of whether the game was in Story Mode or Versus Mode.*

8-3 VERSUS MODE

Versus Mode is played with multiple players over several rounds and points are received according to ranking. The player with the most points at the end of the final round becomes the new “Reigning King” and can have his or her name displayed during the advertisements.

NOTE: If network play is configured, the game will wait for other players to join after starting and will accept entries from the other cabinets. However, when games are already in progress on the other cabinets or at other times when entries cannot be accepted, the game will automatically proceed to Story Mode without waiting.



8-3 FIG. 01 Entry Waiting Screen

- 1 If other players join on the Entry Waiting Screen, Versus Mode will begin. If no other players join within the allotted time, the game will automatically proceed to Story Mode.
- 2 You will be taken to the Motorcycle Selection Screen. Select 1 motorcycle from the many available. Each motorcycle has its own features, so select one that suits you.
- 3 After selecting your motorcycle, you will be taken to the Music Selection Screen. Select 1 song from the many available. The selected song will be played during the game to enliven the mood. The song can also be changed during the game by pressing the Music Select Button.
- 4 After selecting music, you will be taken to the Course Selection Screen. Select the course you wish to compete in from the 2 available. In Versus Mode, course confirmation is decided by the most votes. If 2 courses have the same number of votes, then the course with the lowest difficulty rating will be chosen.

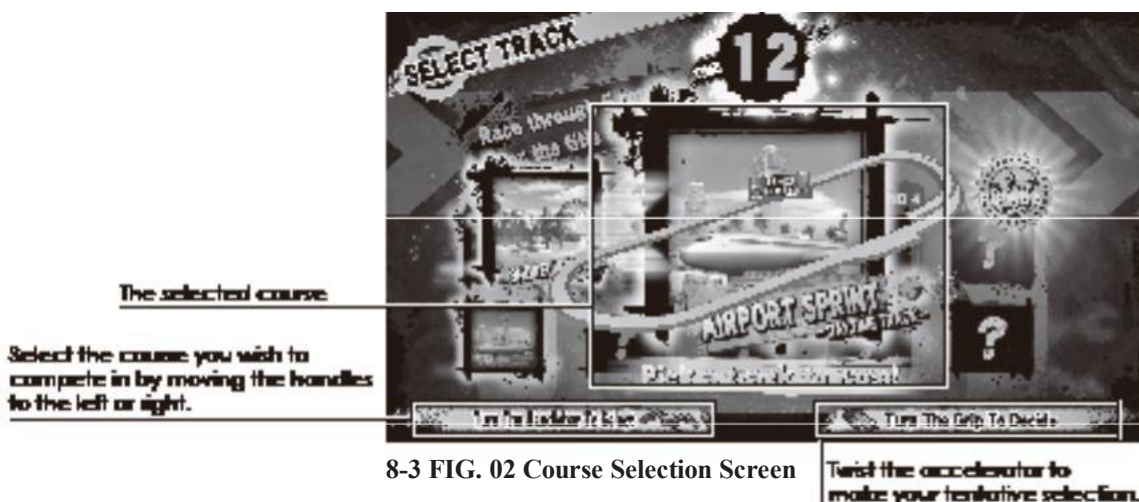

8-3 FIG. 02 Course Selection Screen

- 5 After selecting the course, several cut scenes will follow and you will be taken to the Game Play Screen. In Versus Mode, the players compete 1 round at a time, and the winner is determined by who has the most points after the final round.

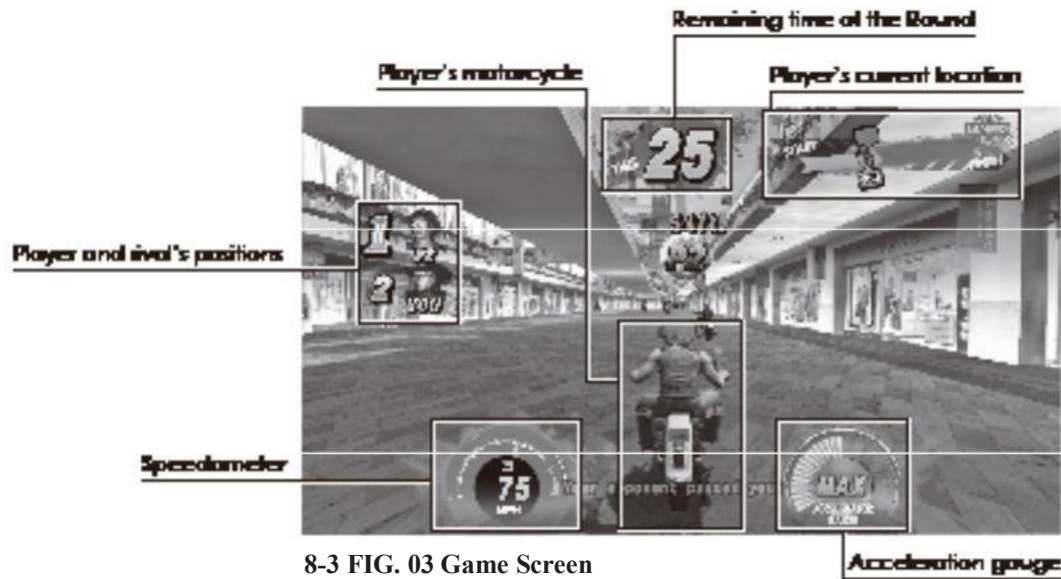

8-3 FIG. 03 Game Screen

- 6 See Step 3 under “8-2 Story Mode” for details on the operations available during game play.

- 7 In Versus Mode, you will be taken to the Continue Screen after the round ends. If you wish to CONTINUE, insert the required number of coins and press the START button again. If there are enough credits remaining to CONTINUE, you can join again by pressing the START button.
NOTE: In Game Test Mode, the settings can be changed so that the player coming in 1st can proceed to the next round. (See 9-3-4.)



8-3 FIG. 04 Continue Screen

- 8 When a game is continued and other players have joined, game play will resume on the next round after the players have selected their motorcycles and music. If no other players have joined, the game will proceed to Story Mode.
- 9 Points are received according to ranking. The player with the most points at the end of the final round will be able to enter his or her name on the Name Entry Screen, and have it displayed during the advertisements as the “Reigning King.”
NOTE: The “Current King” is the player most recently registered as a “Reigning King,” regardless of whether the game was in Story Mode or Versus Mode.

8-4 HINTS FOR PLAYING THE GAME

- Find a motorcycle that matches your playing style.
Each motorcycle has its own unique features. There are fast types, cornering types, strong types, balance types, and others. Assess the features of the motorcycles, find the one that matches your playing style, and learn how to ride it proficiently.
- Find your best course.
The courses have various shapes and gimmicks. Find the best and worst courses for your motorcycle and select the ones that match your playing style.
- Slow down early when approaching sharp curves.
There are some curves in the courses that cannot be cornered at top speed. Try to slow down before the curves and corner them smoothly, rather than running into obstacles and losing time. This is the key to playing better.
- Fill your acceleration gauge by collecting items.
There are several items along the courses that will fill your acceleration gauge. Collect as many as you can so that you will have Super Acceleration ready to use whenever you need it.
- Use Super Acceleration effectively.
Super Acceleration can be used for as long as your acceleration gauge is filled. Assess the shape of the course you are on and think about the best time to use it. For example, it would be effective to use it on long straight aways when your gauge is sufficiently filled.

Items



Acceleration gauge increases by 1.

8-4 FIG. 01



Acceleration gauge increases to the MAX.

8-4 FIG. 02



Acceleration gauge increases by 5.

8-4 FIG. 03

9 EXPLANATION OF TEST AND DATA DISPLAY

WARNING

Do not touch any parts that are not specified in these directions. Touching unspecified locations may lead to electric shock or cause short circuits.

CAUTION

- Be careful that a finger or hand does not get caught when opening/closing the coin chute door.
- When you enter Test Mode, the locks on the handles and motorcycle mechanism will release. If you press the TEST Button while leaning on the motorcycle mechanism which tilts, you could fall off. The locks will be activated again when you exit Test Mode.

IMPORTANT

- When you enter the Test Mode, fractional coin and bonus adder data is erased.
- Adjust the sound to the optimum volume, taking into consideration the environmental requirements of the installation location.
- Removing the coin meter circuitry renders the game inoperable.
- If multiple game machines are connected for network play and you enter Test Mode on one of them, all the others will produce an error. Therefore, do not use Test Mode if people are playing on the other game machines.

This product uses a LINDBERGH RED EX game board and a DVD DRIVE. In the system, a different game can be played by putting a different DVD ROM in the DVD DRIVE.

For this reason, the product's Test Mode consists of two modes: a System Test Mode for systems in which coin settings, for instance, are made for products that use the same system, and a Game Test Mode for setting of difficulty level, etc., and for input/output test of operational units used exclusively with this product.

Perform tests and data checks periodically by manipulating the TEST Button and SERVICE Button in the cabinet. Follow the instructions in this chapter to conduct checks when the game machine is first installed, when money is being collected, or when the game machine does not operate properly.

Shown below are the tests and screens to be used for different problems.

NOTE: "S/M" in the table denotes LINDBERGH RED EX Service Manual, which is provided with the product.

ITEMS	DESCRIPTION	REFERENCE SECTIONS
Game machine installation	1. Investigate each input device on the Input Test Screen.	6-12, 9-3-2
	2. Investigate each output device on the Output Test Screen.	6-12, 9-3-3
	3. Adjust the controllers on the Input Adjustment Screen.	9-3-5
Periodic maintenance	1. Check settings.	9-3-4
	2. Test each input device on the Input Test Screen.	9-3-2
	3. Test each output device on the Output Test Screen.	9-3-3
Control problem	1. Investigate each input device on the Input Test Screen.	9-3-2
	2. Adjust or replace each input device.	9-3-5, Chapters 10 & 11
Monitor problem	On the Monitor Adjustment Check Screen, check to be sure the monitor has been adjusted properly.	Chapter 13, "S/M" Chapter 4
IC board problem	1. Information Display Screen.	"S/M" Chapter 4
	2. Speaker Test.	"S/M" Chapter 4
Date check	Check data on game play times, histograms, etc., and adjust the level of difficulty.	9-3-4, 9-3-8

9-1 SWITCH UNIT AND COIN METER

In Test Mode, the switch unit in the coin chute door is operated.
Use the master key, unlock and open the coin chute door. Inside is a switch unit.

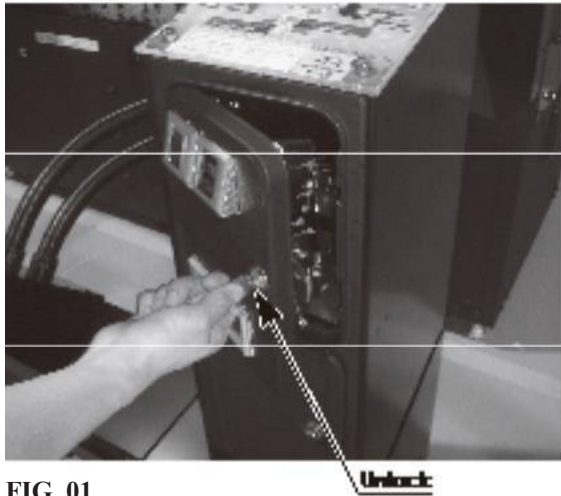

9-1 FIG. 01

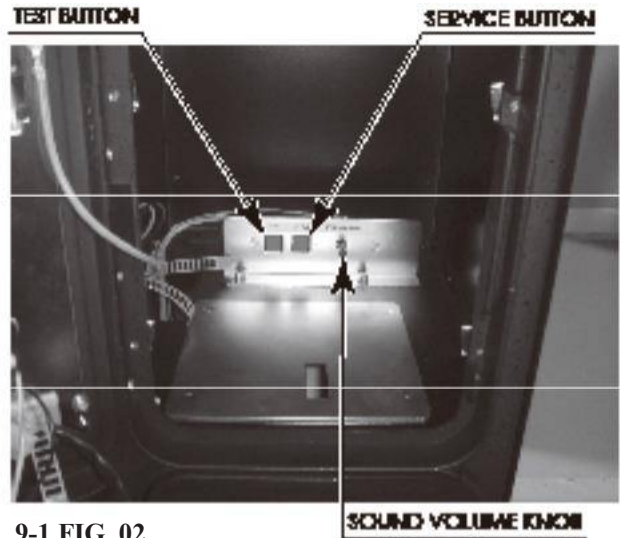

9-1 FIG. 02

- TEST Button** Establishes Test Mode. Becomes the button to confirm selections in Test Mode.
- SERVICE Button** Makes it possible to enter credits for service without increasing the coin meter. Becomes the button to select items in Test Mode.
- Sound Volume Knob** This is the volume knob for speakers at the left and right of the front panel. Turn the knob to the right to increase speaker volume.

Coin Meter

After using a key to unlock the cashbox door, the coin meter can be found at the bottom of the cashbox.

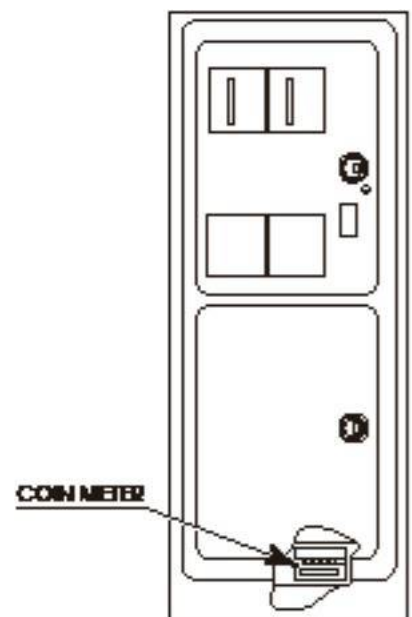

9-1 FIG. 03

9-2 SYSTEM TEST MODE



- Read the LINDBERGH RED EX Service Manual that comes with the product for details on the System Test Mode. However, you should perform the settings for this product according to the manual you are reading.
- The details of changes to Test Mode settings are saved when you exit from Test Mode by selecting EXIT from the system Test Mode menu. Be careful because if the power is turned off before that point, changes to the settings will be lost.

In the System Test Mode, the main activities include checking LINDBERGH RED EX information and actions and the setting of coin/credit. Also, a screen appears for checking screen adjustments. For details, see the LINDBERGH RED EX Service Manual, which is provided with the product.

Use the following settings with this product.

If the settings are not as specified, error messages might appear and operations might not be normal.

COIN ASSIGNMENTS	
COIN CHUTE TYPE	COMMON
SERVICE TYPE	COMMON
NETWORK SETTING	
MAIN NETWORK	
DHCP	DISABLE

NOTE: Settings other than DHCP do not need to be configured.

Replacing the Denomination Sheet

If the COIN ASSIGNMENTS settings were changed in System Test Mode, replace the denomination sheet.

1

Turn the power

2

Remove the 4 hexagon socket screws and take the instruction plate off.

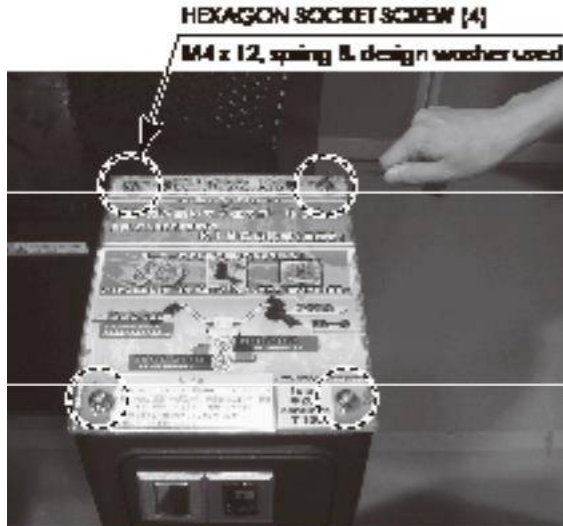

9-2 FIG. 01



9-2 FIG. 02

3

Swap and affix the denomination sheets.

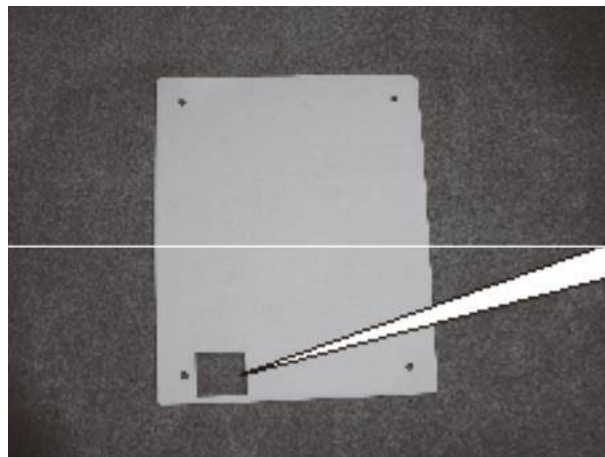

5 FIG. 03



9-3 GAME TEST MODE

When the TEST Button is pressed, the System Test Menu Screen (SYSTEM TEST MENU) appears. Use the SERVICE Button to move the cursor to the desired test item. Select GAME TEST MODE and press the TEST Button to display the Game Test Mode Screen.



To change settings in the Game Test Mode, simply making changes on the setting screen will not be effective. Complete the Test Mode in normal fashion.

9-3-1 GAME TEST MODE

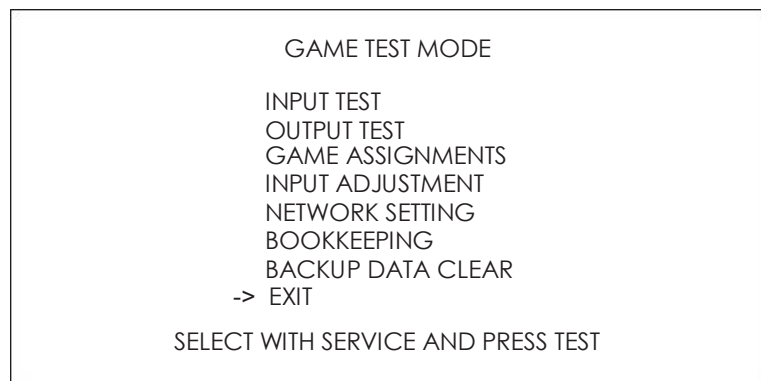

9-3-1 FIG. 01 GAME TEST MODE Screen

Operating Instructions

- Use the SERVICE Button to move the cursor to the desired test item.
- Press the TEST Button to select the test item.
- On the GAME TEST MODE screen, select EXIT and press the TEST Button. The SYSTEM TEST MENU screen reappears.

Explanation of Each Item

INPUT TEST	Tests each input device used for game.
OUTPUT TEST	Tests each output device used for game.
GAME ASSIGNMENTS	Adjusts all game settings.
INPUT ADJUSTMENT	Adjusts the Controller.
NETWORK SETTING	Adjusts all network settings.
BOOKKEEPING	Displays all recorded game data.
BACKUP DATA CLEAR	Erases all types of game records.

9-3-2 INPUT TEST

Select INPUT TEST to display the following screen and check the status of input devices. This test should be used periodically to check that each input device is functioning correctly.

Select INPUT TEST on the GAME TEST MODE Screen and press the TEST Button. A screen will be displayed asking whether or not to initialize the cabinet.

NOTE: If the LEAN option is set to OFF on the GAME ASSIGNMENTS Screen, the INPUT TEST Screen will appear without displaying the Initialize Screen. (See 9-3-4.)

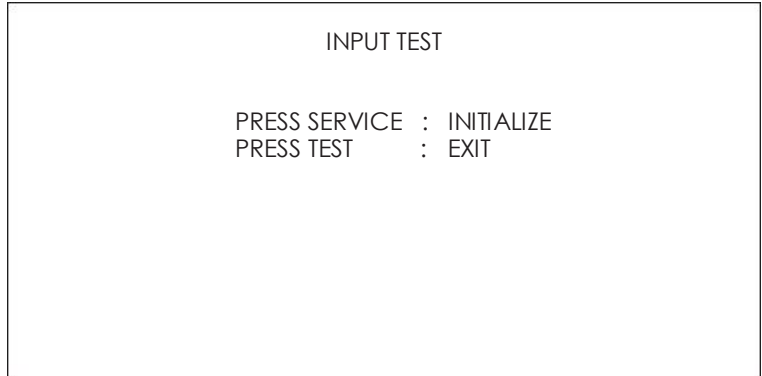

9-3-2 FIG. 01 Initialize Screen

NOTE: The following caution message will be displayed while the cabinet is being initialized:

The seat is being initialized.
For your own safety, please do not touch the seat.

Operating Instructions

Press the SERVICE Button to start initializing the cabinet. When initialization is complete, it will proceed to the INPUT TEST Screen.

Press the TEST Button to return to the GAME TEST MODE Screen.

NOTE: With this game, if the motor or other parts malfunction during the initialization process, the initialization process will be terminated and it will return to the INPUT TEST Screen. If that happens, an error message will be displayed at the bottom of the screen according to the particular problem.

The error message will be displayed not only during the initialization process, but also when there is a problem during the INPUT TEST. Refer to “9-4 Error Messages” to address the problem.

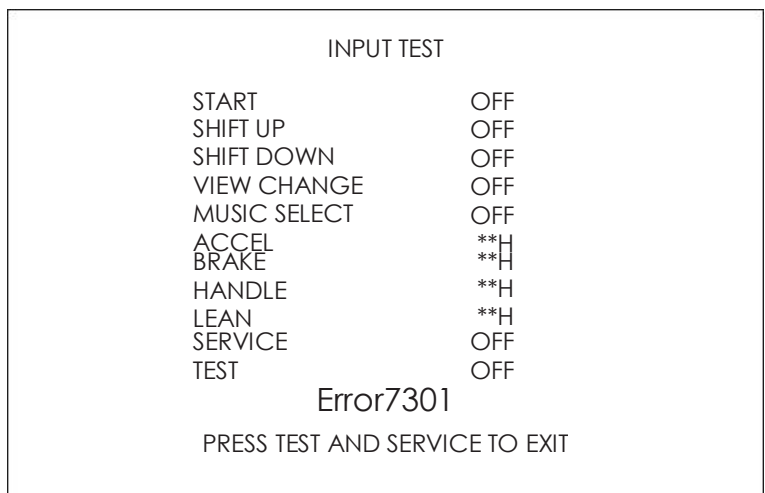

9-3-2 FIG. 02 INPUT TEST Screen (When an error is displayed)

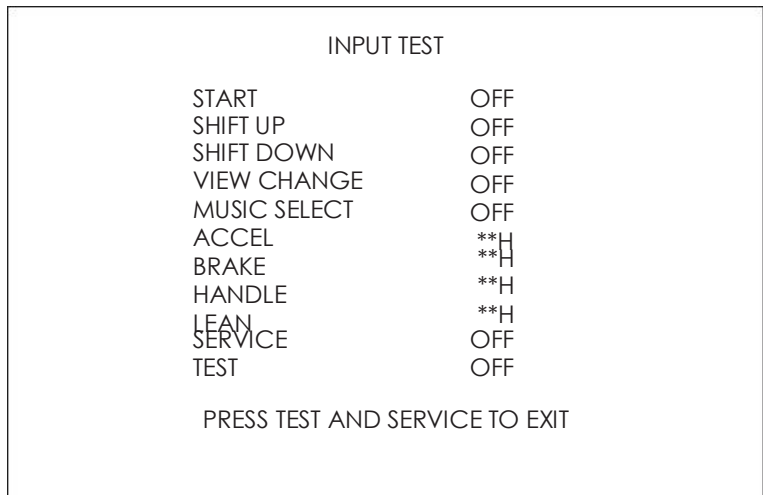

9-3-2 FIG. 03 INPUT TEST Screen

Operating Instructions

When the buttons are pressed, the message should switch from OFF to ON or the numbers should change.

Explanation of Each Item

START	START button
SHIFT UP	SHIFT UP button on left side of HANDLE
SHIFT DOWN	SHIFT DOWN button on left side of HANDLE
VIEW CHANGE	VIEW CHANGE button
MUSIC SELECT	MUSIC SELECT button
ACCEL	Numbers will change when the ACCELERATOR is twisted.
BRAKE	Numbers will change when the BRAKE is pulled.
HANDLE	Numbers will change when the HANDLE is tilted to the left or right.
LEAN	Numbers will change when the MOTORCYCLE MECHANISM is tilted to the left or right. <i>NOTE: If the LEAN option on the GAME ASSIGNMENTS Screen is set to OFF, it will be grayed out and the test will not be available. (See 9-3-4.)</i>
SERVICE	SERVICE Button
TEST	TEST Button

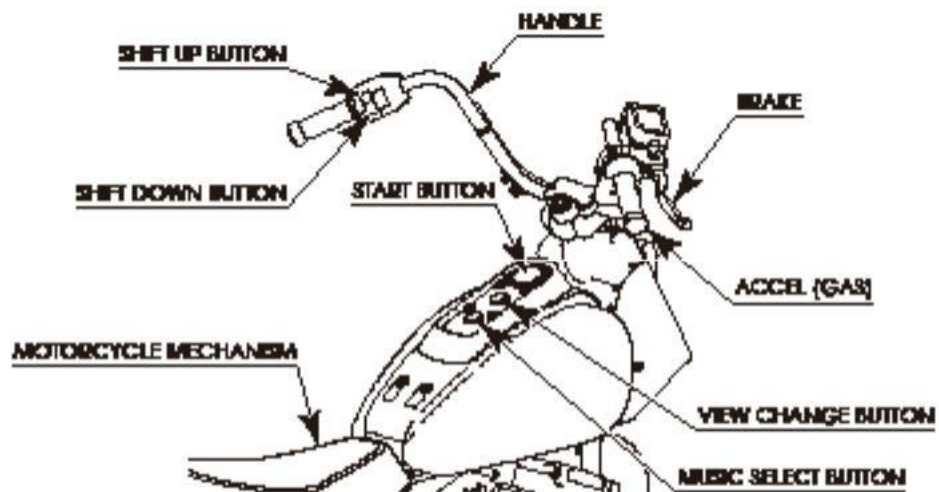

9-3-2 FIG. 04

Press the SERVICE and TEST Buttons simultaneously to return to the GAME TEST MODE screen.

9-3-3 OUTPUT TEST

Perform the output tests for the functions used in the game.
Use this screen periodically to check and make sure the output devices are working properly.

Select OUTPUT TEST on the GAME TEST MODE Screen and press the TEST Button. A screen will be displayed asking whether or not to initialize the cabinet.

NOTE: If the LEAN option is set to OFF on the GAME ASSIGNMENTS Screen, the INPU TEST Screen will appear without displaying the Initialize Screen. (See 9-3-4.)

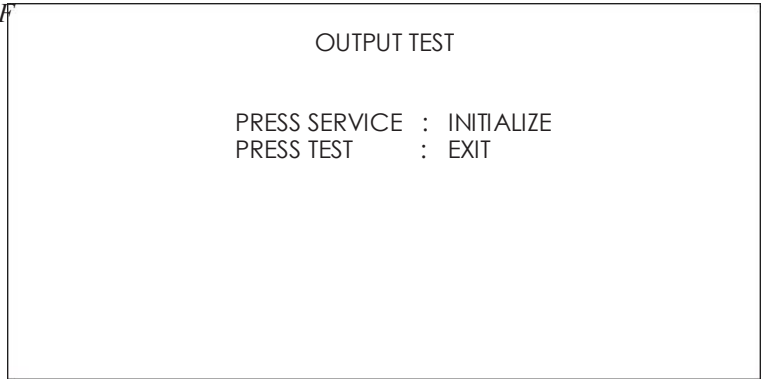

9-3-3 FIG. 01 INITIALIZE Screen

NOTE: The following caution message will be displayed while the cabinet is being initialized:

The seat is being initialized.
For your own safety, please do not touch the seat.

Operating Instructions

Press the SERVICE Button to start initializing the cabinet. When initialization is complete, it will proceed to the OUTPUT TEST Screen.
Press the TEST Button to return to the GAME TEST MODE Screen.

NOTE: With this game, if the motor or other parts malfunction during the initialization process, the initialization process will be terminated and it will return to the OUPUT TEST Screen. If that happens, an error message will be displayed at the bottom of the screen according to the particular problem. The error message will be displayed not only during the initialization process, but also when there is a problem during the OUTPUT TEST. Refer to “9-4 Error Messages” to address the problem.

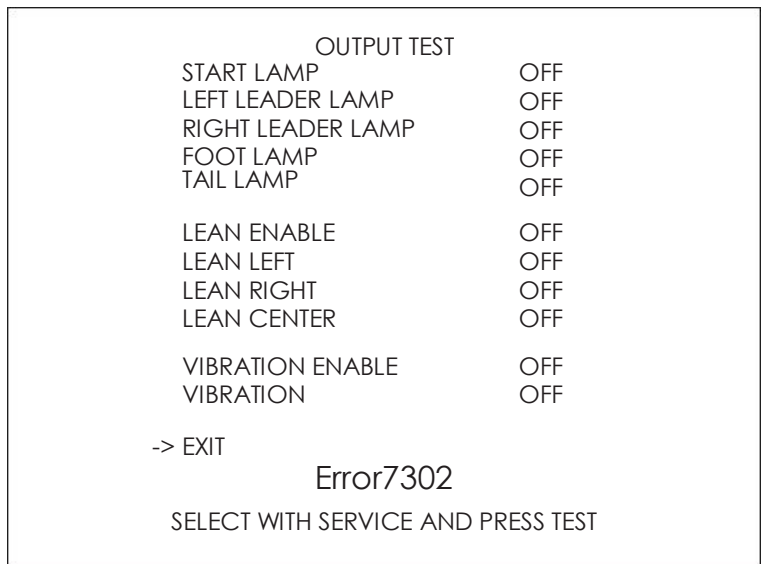

9-3-3FIG. 02 OUTPUT TEST Screen (When an error is displayed)

OUTPUT TEST	
START LAMP	OFF
LEFT LEADER LAMP	OFF
RIGHT LEADER LAMP	OFF
FOOT LAMP	OFF
TAIL LAMP	OFF
LEAN ENABLE	OFF
LEAN LEFT	OFF
LEAN RIGHT	OFF
LEAN CENTER	OFF
VIBRATION ENABLE	OFF
VIBRATION	OFF
-> EXIT	
SELECT WITH SERVICE AND PRESS TEST	

9-3-3 FIG. 03 OUTPUT TEST Screen

Explanation of Each Item

START LAMP	Select START LAMP and press the TEST Button to change it to ON. The Start Button on the cabinet will light up. Press the TEST Button again to change it to OFF.
LEFT LEADER LAMP	Select LEFT LEADER LAMP and press the TEST Button to change it to ON. The upper left lamp on the DLP projector will light up. Press the TEST Button again to change it to OFF.
RIGHT LEADER LAMP	Select RIGHT LEADER LAMP and press the TEST Button to change it to ON. The upper right lamp on the DLP projector will light up. Press the TEST Button again to change it to OFF.
FOOT LAMP	Select FOOT LAMP and press the TEST Button to change it to ON. The lamps on the left and right steps on the cabinet will light up. Press the TEST Button again to change it to OFF.
TAIL LAMP	Select TAIL LAMP and press the TEST Button to change it to ON. The lamp on the back of the cabinet will light up. Press the TEST Button again to change it to OFF.
LEAN ENABLE	Select LEAN ENABLE and press the TEST Button to change it to ON. The lock on the motorcycle mechanism will be released. Press the TEST Button again to change it to OFF. The lock on the motorcycle mechanism will be activated. Also, when the LEAN ENABLE option is set to OFF, selecting LEAN LEFT, LEAN RIGHT, or LEAN CENTER and pressing the TEST Button will change it to ON.
LEAN LEFT	Select LEAN LEFT and press the TEST Button to change it to ON. The motorcycle mechanism will tilt to the left. If the TEST Button is pressed again or the LEAN ENABLE, LEAN RIGHT, or LEAN CENTER options are set to ON and the motorcycle mechanism finishes tilting to the left, it will change to OFF.
LEAN RIGHT	Select LEAN RIGHT and press the TEST Button to change it to ON. The motorcycle mechanism will tilt to the right. If the TEST Button is pressed again or the LEAN ENABLE, LEAN LEFT, or LEAN CENTER options are set to ON and the motorcycle mechanism finishes tilting to the right, it will change to OFF.

LEAN CENTER	Select LEAN CENTER and press the TEST Button to change it to ON. The motorcycle mechanism will return to its upright position. If the TEST Button is pressed again or the LEAN ENABLE, LEAN LEFT, or LEAN RIGHT options are set to ON and the motorcycle mechanism finishes returning to its upright position, it will change to OFF.
VIBRATION ENABLE	Select VIBRATION ENABLE and press the TEST Button to change it to ON. The motorcycle mechanism's motor lock will be released. Press the TEST Button again to change it to OFF. The motor lock will be activated.
VIBRATION	Select VIBRATION and press the TEST Button to change the setting to a number between 1 and 15. Each number corresponds to the level of motor vibration. The higher the number, the stronger the vibration. Press the TEST Button again to change it to OFF. Also, if you select VIBRATION and press the TEST Button when the VIBRATION ENABLE option is set to OFF, the number will be displayed and the VIBRATION ENABLE option will change to ON at the same time.

NOTE: If the LEAN option on the GAME ASSIGNMENTS Screen is set to OFF, the LEAN ENABLE, LEAN LEFT, LEAN RIGHT, and LEAN CENTER options will be grayed out and the test will not be available. (See 9-3-4.) If the VIBRATION option on the GAME ASSIGNMENTS Screen is set to OFF, the VIBRATION ENABLE and VIBRATION options will be grayed out and the test will not be available. (See 9-3-4.)

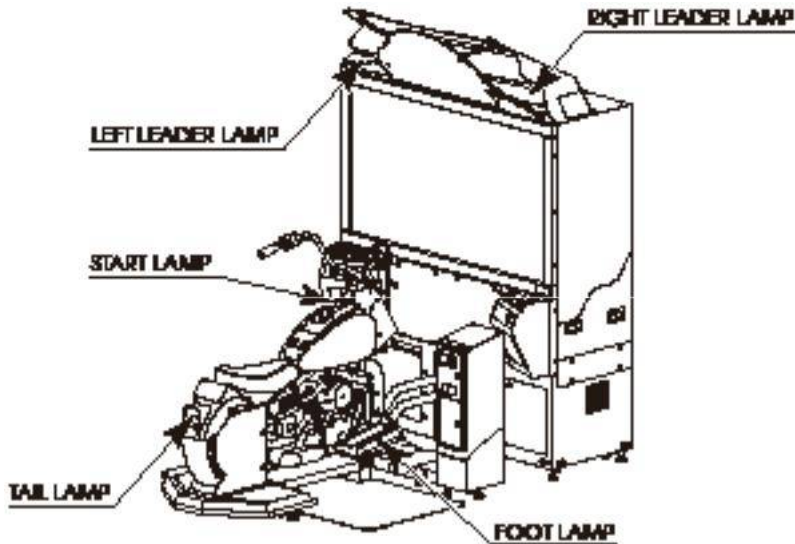

9-3-3 FIG. 04

Move the cursor to EXIT and press the TEST Button to return to the GAME TEST MODE screen.

9-3-4 GAME ASSIGNMENTS



Changes to settings are not enabled until Game Test Mode is exited. After changing settings, be sure to exit Game Test Mode.

Configure the game settings.

GAME ASSIGNMENTS	
CABINET TYPE	DELUXE
LEAN	ON
VIBRATION	ON
ADVERTISE SOUND	ON
ADVERTISE VIBRATION	ON
GAME DIFFICULTY	
STORY MODE	NORMAL
VERSUS MODE	NORMAL
VERSUS MODE 1st CONTINUE	OFF
DRESS CODE	LOW
SPEED DISPLAY	KM
-> EXIT	
SELECT WITH SERVICE AND PRESS TEST	

9-3-4 FIG. 01 GAME ASSIGNMENTS Screen

Explanation of Each Item

CABINET TYPE	Set the cabinet type DELUXE or STANDARD. <i>NOTE: Set the DELUXE in this game machine.</i>
LEAN	If the cabinet lean option is set to ON, it will move. If it is set to OFF, it will not move. <i>NOTE: If CABINET TYPE is not set to DELUXE, it will be grayed out and will not be available.</i>
VIBRATION	If the cabinet motor vibration option is set to ON, it will vibrate. If it is set to OFF, it will not vibrate. <i>NOTE: If CABINET TYPE is not set to DELUXE, it will be grayed out and will not be available.</i>
ADVERTISE SOUND	Set the sound for the advertisements. There are five levels: ON → 3/4 → 1/2 → 1/4 → OFF. The volume gets lower the closer it gets to OFF.
ADVERTISE VIBRATION	Set the motor vibration during advertisements. If it is set to ON, it will vibrate during the advertisements. If it is set to OFF, it will not vibrate. If VIBRATION is set to OFF, this option will be grayed out and will not be available.
GAME DIFFICULTY > STORY MODE	Select from 5 levels of difficulty for Story Mode: VERY EASY → EASY → NORMAL → HARD → VERY HARD. The level of difficulty increases the closer it gets to VERY HARD.
GAME DIFFICULTY > VERSUS MODE	Select from 5 levels of difficulty for Versus Mode: VERY EASY → EASY → NORMAL → HARD → VERY HARD. The level of difficulty increases the closer it gets to VERY HARD.

VERSUS MODE 1st CONTINUE	Set whether or not to allow the player coming in 1st to proceed to the next round in Versus Mode. If the option is set to OFF, all players' game will end on that round (Continue Screen will be displayed).
DRESS CODE	Set the amount of clothing that the female characters in the game wear to LOW or HIGH. The clothing is normal at the LOW setting, and at HIGH it will cover more skin.
SPEED DISPLAY	Set the speedometer to display speed in KM (kirometers per hour; km/h) or MILE (miles per hour; MPH). (Default setting: KM)

NOTE: If STAND ALONE or SUB is selected for the MODE option on the NETWORK SETTING Screen, the options that cannot be selected under GAME ASSIGNMENTS will be grayed out and will not be available.

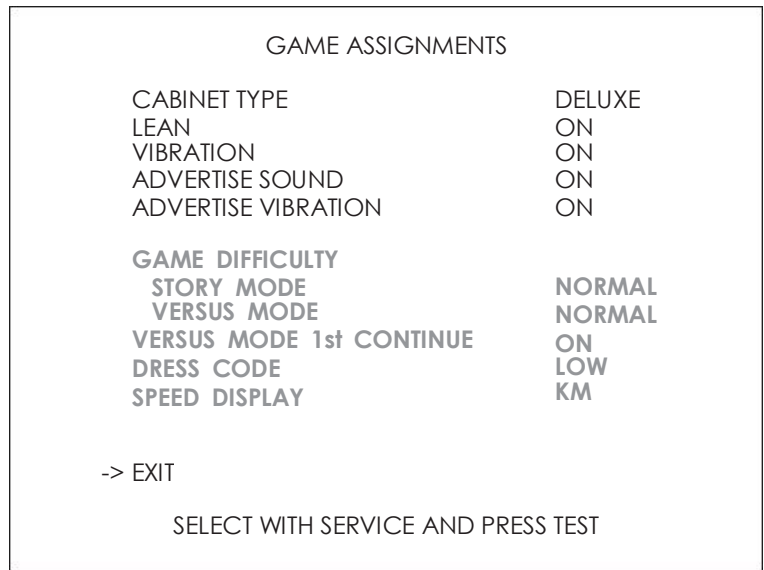

9-3-4 FIG. 02 GAME ASSIGNMENTS Screen (SUB)

Move the cursor to EXIT and press the TEST Button to return to the GAME TEST MODE screen.

9-3-5 INPUT ADJUSTMENT



When adjusting the HANDLE, ACCELERATOR, and BRAKE settings, it is not necessary to tilt the HANDLE, twist the ACCELERATOR, or pull the BRAKE all the way to their limits. If excessive force is applied, it could end up breaking them or causing problems during the game so be careful.

Adjust the controllers used in the game:

INPUT ADJUSTMENT

	MIN	NOW	MAX	
HANDLE	[**H]	[**H]	[**H]	
		c		
	Left [0]	Right
ACCEL	[**H]	[**H]	[**H]	
	Min [0			Max
BRAKE	[**H]	[**H]	[**H]	
	Min [0			Max

DEFAULT SETTING

EXIT : MEMORIZE
-> EXIT : CANCEL

SELECT WITH SERVICE AND PRESS TEST

9-3-5 FIG. 01 INPUT ADJUSTMENT

Explanation of Each Item

HANDLE	This option sets the left-right offset for the handle. Tilt the handle all the way to the left and right and return it to the center position. <i>NOTE: "c" indicates the center position set for the handle.</i>
ACCEL	This option sets the offset for when the accelerator is twisted. Twist the accelerator all the way and return it to the starting position.
BRAKE	This option sets the offset for when the brake lever is pulled. Pull the brake lever all the way and return it to the starting position.
DEFAULT SETTING	This option returns the settings to the default values.

Select "EXIT: MEMORIZE" and press the TEST Button to save the settings and return to the GAME TEST MODE Screen.

Select "EXIT: CANCEL" and press the TEST Button to return to the GAME TEST MODE Screen without saving the settings.

9-3-6 NETWORK SETTING

Configure the network settings for the cabinets.

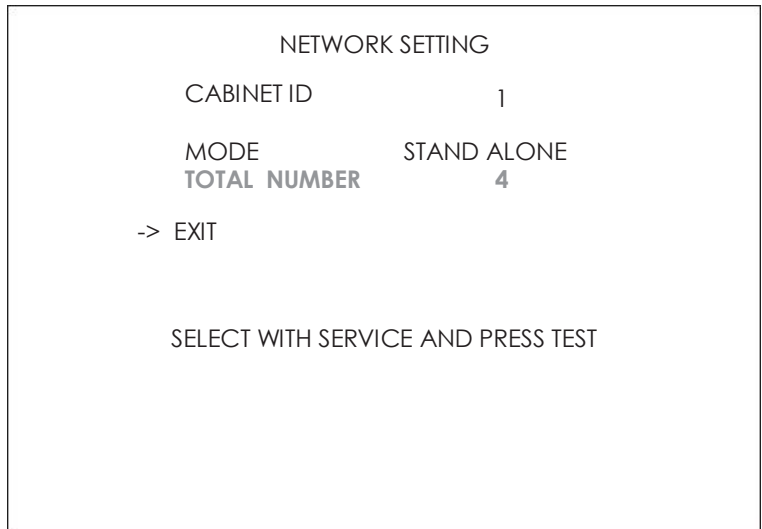

9-3-6 FIG. 01 NETWORK SETTING Screen

Explanation of Each Item

CABINET ID	<p>Assign a number between 1 and 4 to the cabinets, and set the numbers to be identified during communication. If network play will be used, set a different number on each cabinet in the network. It is recommended that you assign the numbers in numerical order from left to right (facing the machines) in order to match them with the results displayed during versus play.</p> <p><i>NOTE: With this game, if the same number is assigned as the CABINET ID for different cabinets in the network, it will give an error when proceeding to the Game Screen and “Error6803” will be displayed on the screen. If that happens, press the TEST Button again and go to SYSTEM TEST MENU → GAME TESTMODE → NETWORK SETTING to change the CABINET IDs to different numbers.</i></p>
MODE	<p>Set the MODE of the cabinet. Choose from STAND ALONE, MAIN, and SUB. STAND ALONE is a setting for when network play will not be used. MAIN is for network play and should be assigned to one of the cabinets. SUB is also for network play and should be assigned to all other cabinets other than the one set as the MAIN cabinet.</p> <p><i>NOTES:</i></p> <ul style="list-style-type: none"> - With this game, if more than one cabinet in the network is set to MAIN, it will give an error when proceeding to the Game Screen and “Error6802” will be displayed on the screen. If that happens, press the TEST Button again and go to SYSTEM TEST MENU → GAME TEST MODE → NETWORK SETTING to change the MODE settings so that only one cabinet is set to MAIN. - With this game, if all the cabinets in the network are set to SUB, it will give an error when proceeding to the Game Screen and “Error6804” will be displayed on the screen. If that happens, press the TEST Button again and go to SYSTEM TEST MENU → GAME TEST MODE → NETWORK SETTING to change the MODE settings so that one of the cabinets is set to MAIN.

TOTAL NUMBER	<p>If the MODE of the cabinet is set to MAIN, set the number of cabinets in the network under TOTAL NUMBER. The number should be equal to the total number of cabinets set to MAIN and SUB. If the MODE of the cabinet is set to something other than MAIN, the TOTAL NUMBER option will be grayed out and will not be available.</p> <p><i>NOTE: With this game, if the TOTAL NUMBER setting does not match the total number of cabinets in the network set to MAIN and SUB, it will give an error when proceeding to the Game Screen and "Error6804," "Error6006," "Error6008," or "Error6009" will be displayed on the screen. If that happens, press the TEST Button again and go to SYSTEM TEST MENU → GAME TEST MODE → NETWORK SETTING to change the TOTAL NUMBER setting to the total number of cabinets that have been set to MAIN and SUB.</i></p>
--------------	---

Move the cursor to EXIT and press the TEST Button to return to the GAME TEST MODE screen.

9-3-7 BOOKKEEPING

The game records can be viewed here.

BOOKKEEPING PAGE 1/7	
COIN 1	0
COIN 2	0
COIN 3	0
COIN 4	0
TOTAL COINS	0
COIN CREDITS	0
SERVICE CREDITS	0
TOTAL CREDITS	0
PRESS TEST TO CONTINUE	

9-3-7 FIG. 01 BOOKKEEPING PAGE 1/7 Screen

Explanation of Each Item

COIN 1	Number of coins inserted in coin chute 1.
COIN 2	Number of coins inserted in coin chute 2.
COIN 3	Number of coins inserted in coin chute 3.
COIN 4	Number of coins inserted in coin chute 4.
TOTAL COINS	Total number of coins inserted in all coin chutes.
COIN CREDITS	Number of credits for coins inserted.
SERVICE CREDITS	Number of credits entered with the SERVICE Button.
TOTAL CREDITS	Total number of all credits.

Press the TEST Button to proceed to the BOOKKEEPING PAGE 2/7 Screen.

BOOKKEEPING PAGE 2/7	
NUMBER OF GAMES	0
FIRST PLAY	0
CONTINUE PLAY	0
TOTAL TIME	0000D 00H 00M 00S
PLAY TIME	0000D 00H 00M 00S
AVERAGE PLAY TIME	00M 00S
LONGEST PLAY TIME	00M 00S
SHORTEST PLAY TIME	00M 00S
PRESS TEST TO CONTINUE	

9-3-7 FIG. 02 BOOKKEEPING PAGE 2/7 Screen

Explanation of Each Item

NUMBER OF GAMES	Total number of games played.
FIRST PLAY	Total number of first plays.
CONTINUE PLAY	Total number of continue plays.
TOTAL TIME	The total operation time
PLAY TIME	Amount of time game has been played.
AVERAGE PLAY TIME	Average length of a single game.
LONGEST PLAY TIME	Longest single game.
SHORTEST PLAY TIME	Shortest single game.

Press the TEST Button to proceed to the BOOKKEEPING PAGE 3/7 Screen.

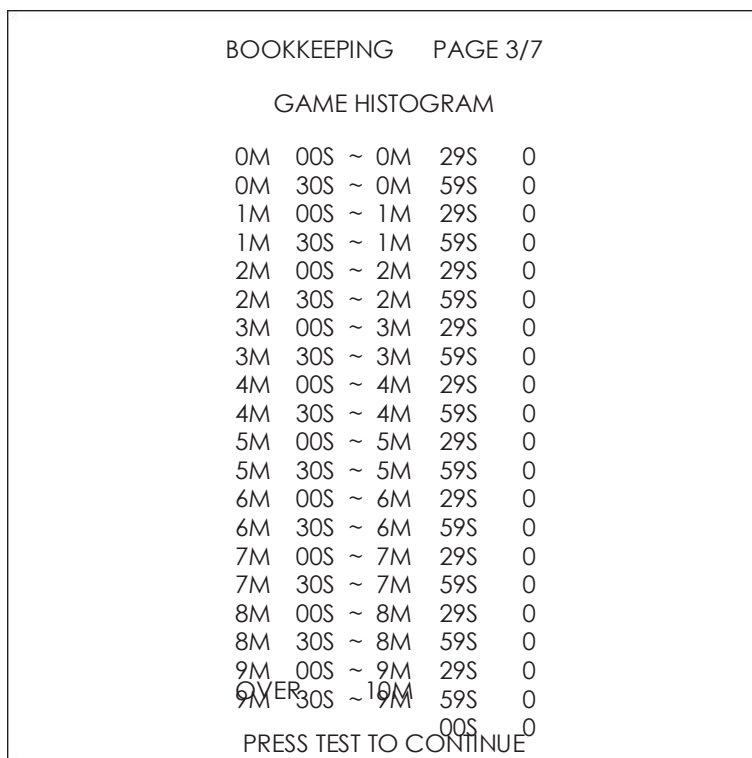

9-3-7 FIG. 03 BOOKKEEPING PAGE 3/7 Screen

This is a list of the total play times in each mode.
 This displays play times on a scale from 0M00S to 9M59S based on 30-second intervals.
 All play times 10 minutes or over are included in the item OVER 10M00S.

Press the TEST Button to proceed to the BOOKKEEPING PAGE 4/7 Screen.

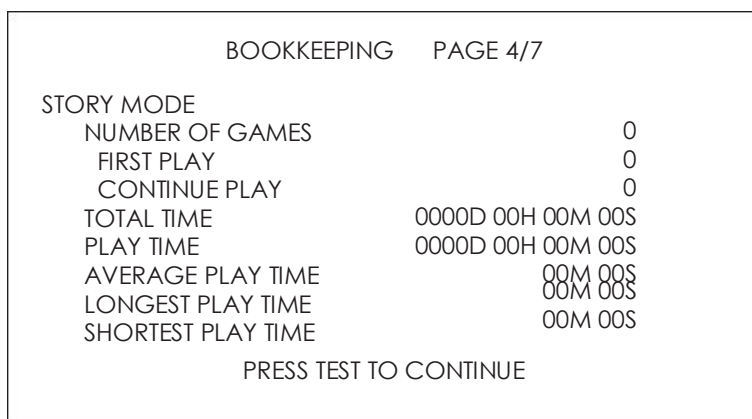

9-3-7 FIG. 04 BOOKKEEPING PAGE 4/7 Screen

Explanation of Each Item

NUMBER OF GAMES	Total number of games played in Story Mode.
FIRST PLAY	Total number of first plays in Story Mode.
CONTINUE PLAY	Total number of continue plays in Story Mode.
TOTAL TIME	The total operation time
PLAY TIME	Amount of time game has been played in Story Mode.
AVERAGE PLAY TIME	Average length of a single game in Story Mode.
LONGEST PLAY TIME	Longest single game in Story Mode.
SHORTEST PLAY TIME	Shortest single game in Story Mode.

Press the TEST Button to proceed to the BOOKKEEPING PAGE 5/7 Screen.

BOOKKEEPING PAGE 5/7					
STORY MODE					
GAME HISTOGRAM					
0M	00S	~	0M	29S	0
0M	30S	~	0M	59S	0
1M	00S	~	1M	29S	0
1M	30S	~	1M	59S	0
2M	00S	~	2M	29S	0
2M	30S	~	2M	59S	0
3M	00S	~	3M	29S	0
3M	30S	~	3M	59S	0
4M	00S	~	4M	29S	0
4M	30S	~	4M	59S	0
5M	00S	~	5M	29S	0
5M	30S	~	5M	59S	0
6M	00S	~	6M	29S	0
6M	30S	~	6M	59S	0
7M	00S	~	7M	29S	0
7M	30S	~	7M	59S	0
8M	00S	~	8M	29S	0
8M	30S	~	8M	59S	0
9M	00S	~	9M	29S	0
OVER	30S	~	10M	59S	0
			00S		0
PRESS TEST TO CONTINUE					

9-3-7 FIG. 05 BOOKKEEPING PAGE 5/7 Screen

This is a list of the total play times in Story Mode.

This displays play times on a scale from 0M00S to 9M59S based on 30-second intervals.

All play times 10 minutes or over are included in the item OVER 10M00S.

Press the TEST Button to proceed to the BOOKKEEPING PAGE 6/7 Screen.

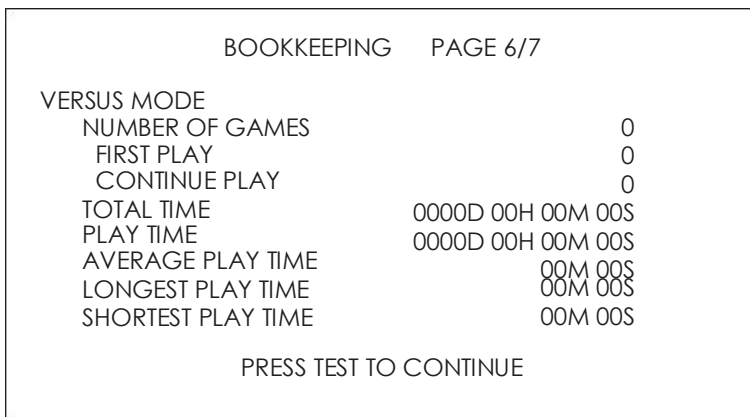

9-3-7 FIG. 06 BOOKKEEPING PAGE 6/7 Screen

Explanation of Each Item

NUMBER OF GAMES	Total number of games played in Versus Mode.
FIRST PLAY	Total number of first plays in Versus Mode.
CONTINUE PLAY	Total number of continue plays in Versus Mode.
TOTAL TIME	The total operation time
PLAY TIME	Amount of time game has been played in Versus Mode.
AVERAGE PLAY TIME	Average length of a single game in Versus Mode.
LONGEST PLAY TIME	Longest single game in Versus Mode.
SHORTEST PLAY TIME	Shortest single game in Versus Mode.

Press the TEST Button to proceed to the BOOKKEEPING PAGE 7/7 Screen.

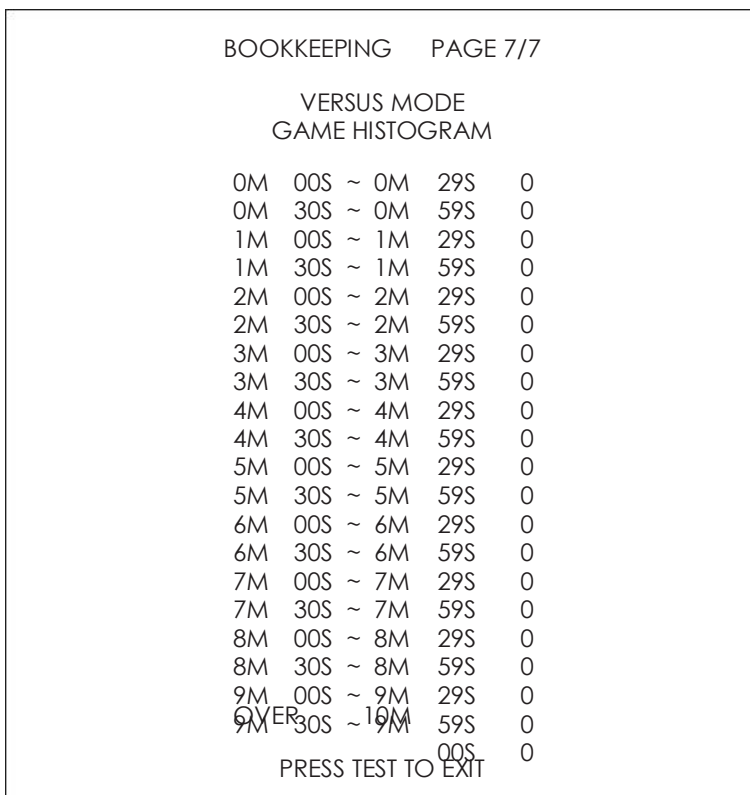

9-3-7 FIG. 07 BOOKKEEPING PAGE 7/7 Screen

This is a list of the total play times in Versus Mode.
 This displays play times on a scale from 0M00S to 9M59S based on 30-second intervals.
 All play times 10 minutes or over are included in the item OVER 10M00S.

Press the TEST Button to return to the GAME TEST MODE Screen.

9-3-8 BACKUP DATA CLEAR

This deletes the various game data (ranking data, BOOKKEEPING data from GAME TEST MODE, and remaining credits).

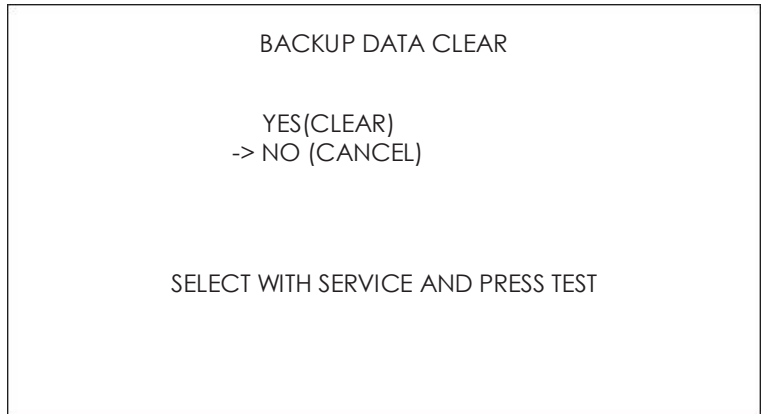

9-3-8 FIG. 01

Explanation of Each Item

YES (CLEAR)	All game records are cleared. After clearing, “COMPLETED” is displayed and press the TEST Button to return to the GAME TEST MODE screen.
NO (CANCEL)	Move the cursor and press the TEST Button to return to the GAME TEST MODE screen without clearing the data.

9-4 ERROR MESSAGES

WARNING

- Should an error message appear, have the facility's maintenance or technical staff deal with the issue. Work by those without the necessary specialized knowledge and technical expertise can result in electric shocks, short circuits, and fires. If such maintenance or technical staff is not available, or if the problem is with the ride mechanisms, immediately turn off the product's power and contact the office listed in this manual or the point of purchase.
- In the event that problems arise beyond those covered in this manual, or if the procedures listed in this document do not solve the problem, do not attempt to solve the problem with careless measures. Immediately turn off the product's power and contact the office listed in this manual or the point of purchase. Improper procedures can result in unforeseen accidents.

IMPORTANT

If an error number or message not listed below is displayed, stop use of the machine and send the LINDBERGH RED EX in for repairs.

This product displays the following messages when it detects an error. Read the error description and follow the steps indicated. Refer to the LINDBERGH Service Manual for details on error messages displayed with the LINDBERGH logo.

NETWORK MESSAGES

DISPLAY	Error6003 Network PacketSize.
CAUSE	The size of the packets transmitted was abnormal during communication.
COUNTERMEASURES	Check to make sure the network cable has been inserted all the way.

DISPLAY	Error6004 Network PacketKind.
CAUSE	The kind of packets transmitted during communication was abnormal.
COUNTERMEASURES	Check to make sure the network cable has been inserted all the way.

DISPLAY	Error6005 Network TimeOut.
CAUSE	Communication was interrupted for a certain length of time due to a problem between the cabinets, the network line being pulled out, etc.
COUNTERMEASURES	Check to make sure the cabinets are on and the network cable has been inserted all the way.

DISPLAY	Error6006 Network SendError.
CAUSE	Sending failed for some reason.
COUNTERMEASURES	Check to make sure the network cable has been inserted all the way.

DISPLAY	Error6007 Network SendTryOut.
CAUSE	Sending failed repeatedly for some reason.
COUNTERMEASURES	Check to make sure the network cable has been inserted all the way.

DISPLAY	Error6008 Network RecvError.
CAUSE	An unknown error occurred while receiving data.
COUNTERMEASURES	Check to make sure the network cable has been inserted all the way.

DISPLAY	Error6009 Network RecvDisconnect.
CAUSE	The connection was broken while data was being received.
COUNTERMEASURES	Check to make sure the cabinets are on and available for play.

DISPLAY	Error6802 Network Setting Many Main.
CAUSE	Multiple cabinets in the network were set to MAIN.
COUNTERMEASURES	Under the LINDBERGH RED EX settings, go to SYSTEM TEST MENU→ GAME TEST MODE→NETWORK SETTING and change the MODE setting.

DISPLAY	Error6803 Network Setting Same Cabinet ID.
CAUSE	Multiple cabinets in the network were assigned the same ID. (CABINET ID is set under NETWORK SETTING→CABINET ID in GAME TEST MODE.)
COUNTERMEASURES	Under the LINDBERGH RED EX settings, go to SYSTEM TEST MENU→ GAME TEST MODE→NETWORK SETTING and change the CABINET ID setting.

DISPLAY	Error6804 Network Setting Error.
CAUSE	There was a problem sending data during communication due to incorrect settings or some other reason.
COUNTERMEASURES	Under the LINDBERGH RED EX settings, go to SYSTEM TEST MENU→ GAME TEST MODE→NETWORKSETTING and check to make sure all the settings are correct.

MOTOR-RELATED ERRORS

DISPLAY	Error7301 Serial AlarmEncoder.
CAUSE	The encoder alarm went off.
COUNTERMEASURES	Check the servo driver motor wiring and then reboot the cabinet.

DISPLAY	Error7302 Serial AlarmOvercurrent.
CAUSE	The overcurrent alarm went off.
COUNTERMEASURES	Turn off the cabinet for a brief period of time and then turn it back on.

DISPLAY	Error7303 Serial AlarmOverheat.
CAUSE	The overheat/overload alarm went off.
COUNTERMEASURES	Turn off the cabinet for a brief period of time and then turn it back on.

DISPLAY	Error7304 Serial DataError.
CAUSE	Communication data was corrupt.
COUNTERMEASURES	Check the wire to the LINDBERGH RED EX COM1 port.

DISPLAY	Error7702 Serial TimeOut.
CAUSE	There was no response from the serial motor driver or it is not connected.
COUNTERMEASURES	Check the wire to the LINDBERGH RED EX COM1 port.

DISPLAY	Error7703 Serial Initial.
CAUSE	The software could not be reset during the initialization process.
COUNTERMEASURES	Reboot the cabinet.

DISPLAY	Error7704 Serial ZeroSearch.
CAUSE	The cabinet is not moving due to a home-position search error.
COUNTERMEASURES	Check to make sure the cabinet is not stuck for some reason.

DISPLAY	Error7705 Serial CenterSearch.
CAUSE	The cabinet is not moving due to a center search error.
COUNTERMEASURES	Check to make sure the cabinet is not stuck for some reason. Check to make sure the movement lock has not come off. Check to make sure there is nothing around the cabinet obstructing its movement.

DISPLAY	Error7801 Roll Volume
CAUSE	The wrong value came back from the roll volume.
COUNTERMEASURES	Check to make sure there is nothing wrong with the roll volume wiring.

10 HANDLE

TOP IMPORTANT

- In order to prevent electric shock and short circuit hazards, be sure to turn the power off before performing work. However, the unit must be switched on when using test mode. Do not touch any part of the unit except those areas indicated.
- Be careful not to damage the wires. Damaged wires may cause electric shock or short circuit.
- Exercise due caution in performing soldering work. If soldering iron is handled carelessly, there could be fires or burns.
- Be sure to perform volume's move value setting in the INPUT ASSIGNMENTS in the Game Test Mode after replacing or adjusting the Volume. Failure to do so could prevent the game from operating properly.

0-1 FRONT BRAKE VOLUME

A tamperproof screw wrench (for M4) is required for the following procedure.

10-1-1 Adjusting the Volume

1

Turn the power

2

Remove the 4 tamperproof screws and take the VR cover off.

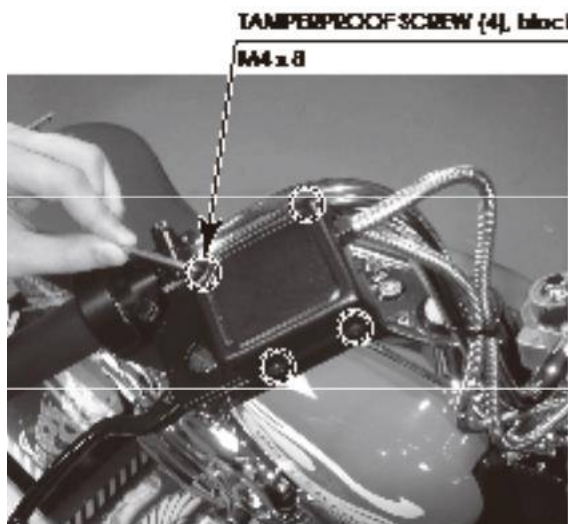

10-1-1 FIG. 01

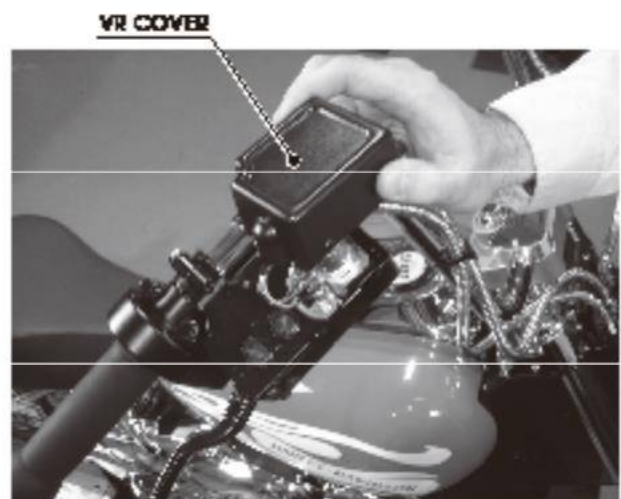

10-1-1 FIG. 02

- Loosen the 2 screws, move the VR bracket, and adjust the angle and way the gears fit together. The brake lever should be released, and the D-cut surface of the volume rotating shaft should be in the position shown in the figure when doing so.

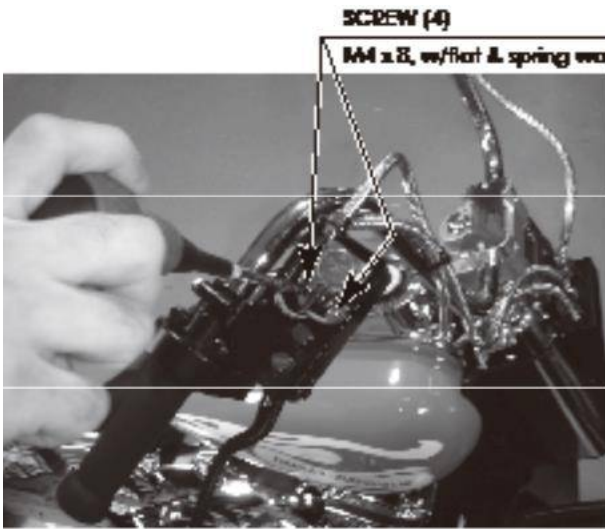

10-1-1 FIG. 03



10-1-1 FIG. 04

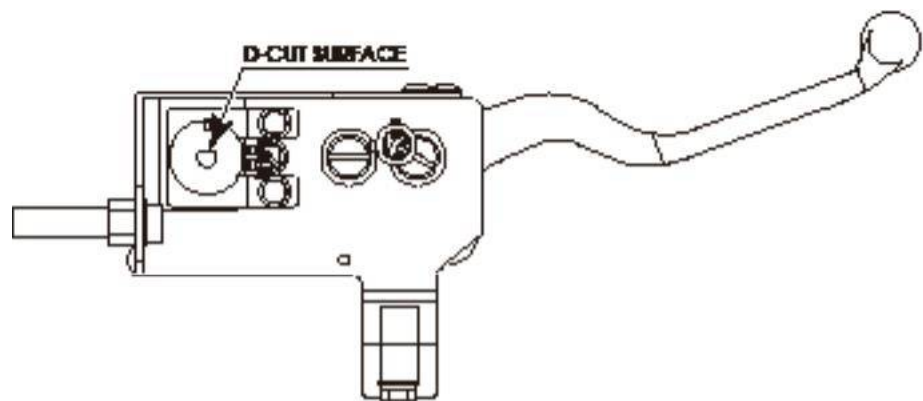

10-1-1 FIG. 05

- After performing the adjustment, use the 2 screws to fully tighten the VR bracket on.
- Operate the brake lever and check to make sure the gears rotate smoothly.
- Refer to Step 2 and attach the VR cover.
- Turn on the power and be careful not to touch the motorcycle mechanism when doing so. The motorcycle mechanism initialization operation will be performed automatically after the power is turned on.
- Set the volume value on the INPUT ADJUSTMENT Screen in Game Test Mode. The recommended value for the front brake volume is “30H±8H” with the brake lever released. Check to make sure the value increases when the brake lever is pulled. (See “9-3-5 INPUT ADJUSTMENT.”)

10-1-2 Replacing the Volume

A replacement volume (220-5753) and 3 heat-shrinkable tubes (310-5029-F20) are required. The following tools and soldering equipment will be used:

- Tamperproof screw wrench (for M4)
- Nipper
- Cutter
- Wire stripper
- Soldering iron
- Industrial dryer

1

Turn the power

2

Refer to Step 2 under “10-1-1 Adjusting the Volume” and remove the VR cover.

3

Remove the 2 screws fastening the VR bracket in place and take the volume off including the VR bracket.

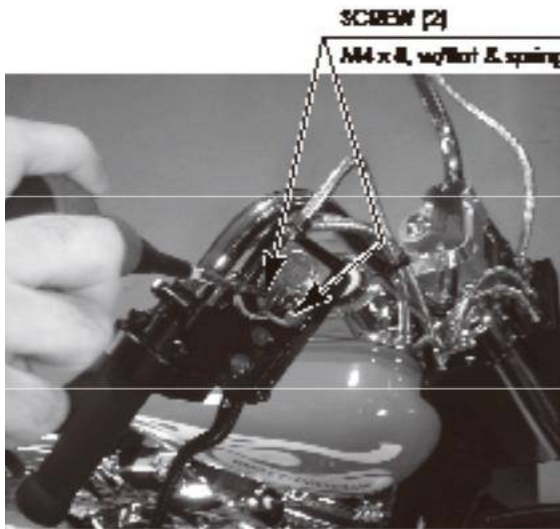

10-1-2 FIG. 01



10-1-2 FIG. 02

4

Remove the 2 hexagon socket screws and pull the gear off the volume shaft.

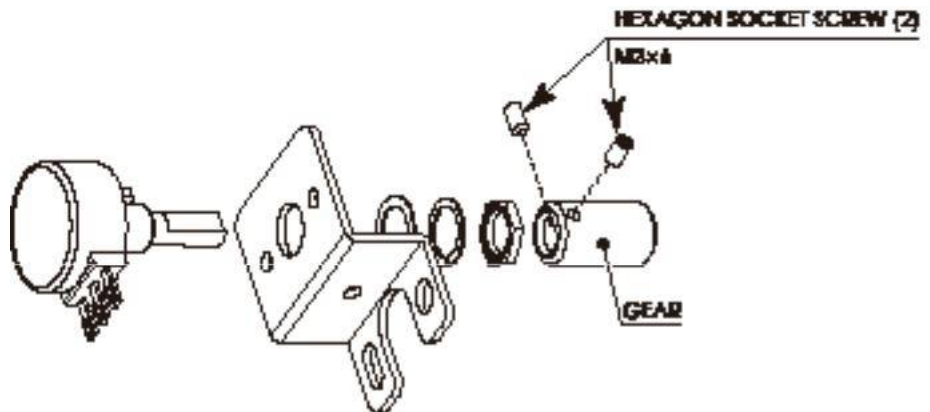

10-1-2 FIG. 03

5 Remove the nut fastening the VR bracket in place and take the volume off the VR bracket. (See 10-1-2 FIG. 03.)

6 The wires connected to the volume will proceed to be used. Use a tool such as nippers or a cutter to remove the old heat-shrinkable tubes from the places where the wires are connected.

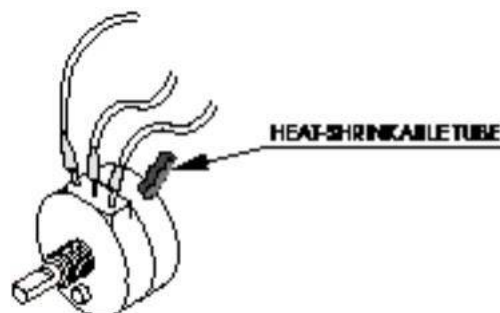

10-1-2 FIG. 04

7 Use a soldering iron to melt the solder and separate the wires from the old volume. Be careful when using the soldering iron.

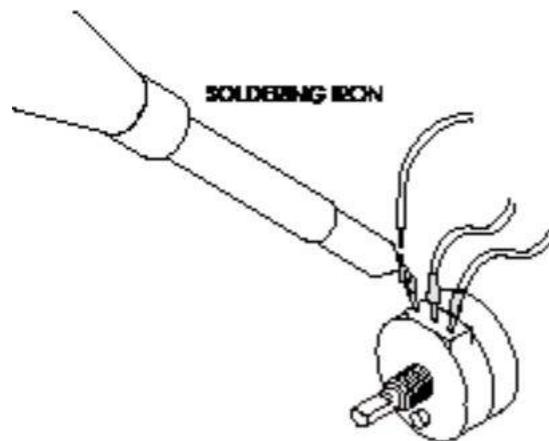

10-1-2 FIG. 05

8 If the exposed conductive wire at the end is less than 5 mm, use a tool such as a wire stripper or cutter to cut the coating back.

9 Pass the wires through the 3 heat-shrinkable tubes.

10 Solder the wires to the terminals on the new volume. Check the wiring diagram and be careful not to mix up the wires.

11 Cover the soldered parts with the heat-shrinkable tubes and apply heat with an industrial dryer until the heat-shrinkable tubes tightly cover the soldered parts.

12 Refer to Steps 3-5 and work in reverse order to attach the volume.

13 Refer to “10-1-1 Adjusting the Volume” and adjust the volume.

10-1-3 GREASING

TOP IMPORTANT

- Be sure to use the designated grease. Using undesignated grease can cause parts damage.
- Do not apply grease to locations other than as specified. Doing so may create a risk of operational problems and deterioration of parts.
- The designated periods for greasing serve only as a guide. Whenever there are squeaks or other anomalies, apply grease at designated locations.

Use spray grease once every three months to grease up the gear mesh portion of the constituent parts.

Use "Grease Mate" (part number 090-0066) for the spray grease.

Refer to Steps 1 and 2 under "10-1-1 Adjusting the Volume" and remove the VR cover. Apply grease between the gears that turn the volume shaft.

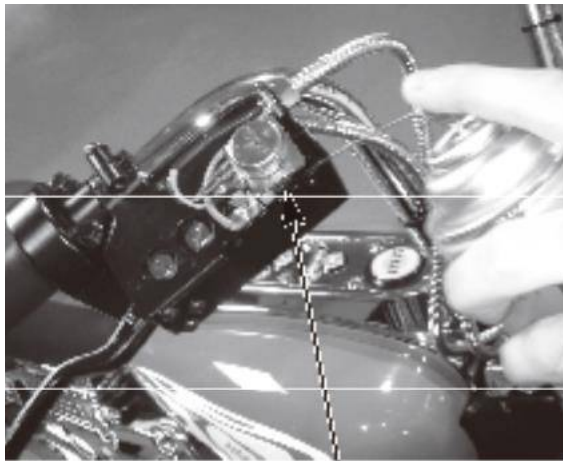

10-1-3 FIG. 01

GEAR MESH PORTION

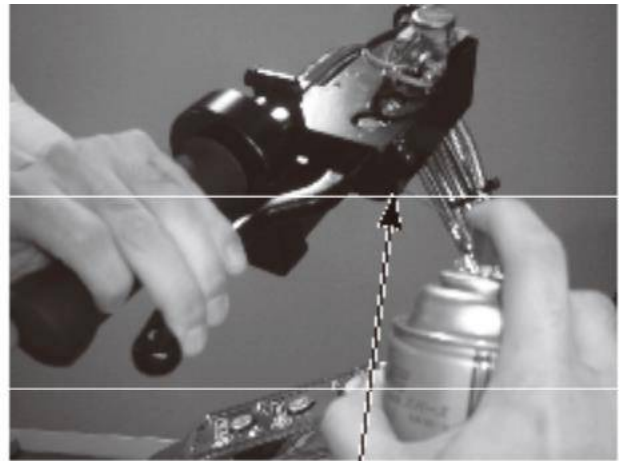

10-1-3 FIG. 02

GEAR MESH PORTION

10-2 ACCELERATOR VOLUME

10-2-1 Adjusting the Volume

A tamperproof screw wrench (for M4) is required for the following procedure.

1 Turn the power

2 of. Remove the 4 tamperproof screws and take the VR cover off.

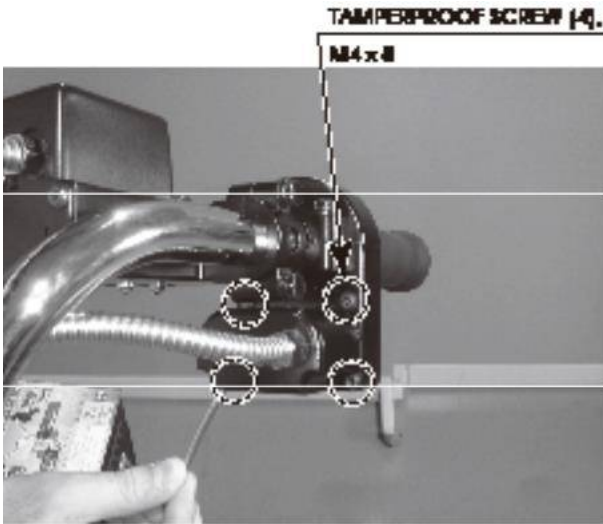

10-2-1 FIG. 01



10-2-1 FIG. 02

3 Loosen the screw, move the VR bracket, and adjust the angle and way the gears fit together. The accelerator should be released, and the D-cut surface of the volume rotating shaft should be in the position shown in the figure when doing so.

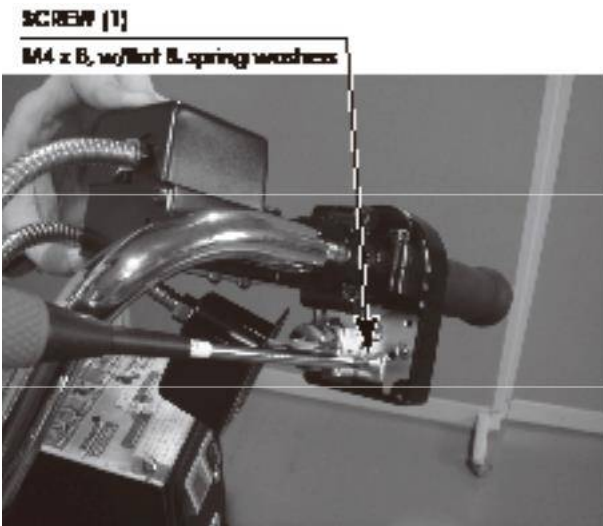

10-2-1 FIG. 03

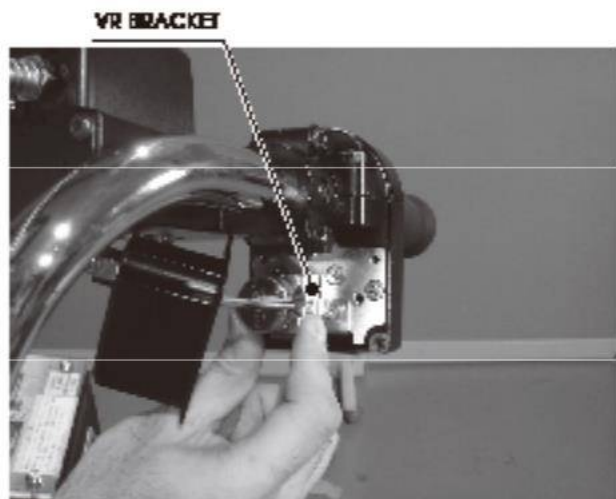

10-2-1 FIG. 04

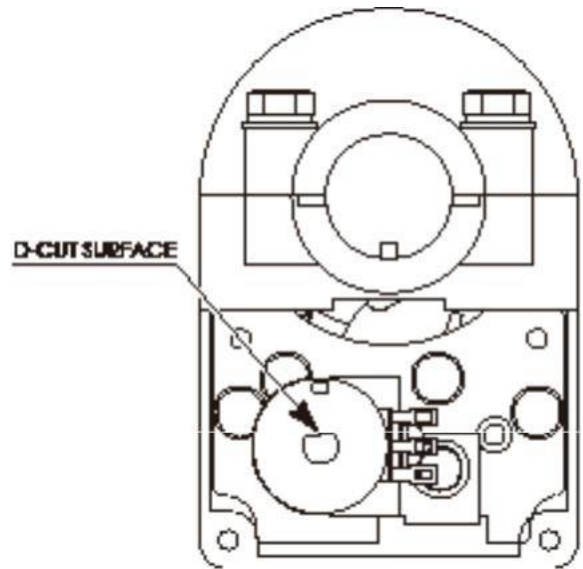

10-2-1 FIG. 05

-
- 4** After performing the adjustment, use the screw to fully tighten the VR bracket on.
-
- 5** Operate the accelerator and check to make sure the gears rotate smoothly.
-
- 6** Refer to Step 2 and attach the VR cover.
-
- 7** Turn on the power and be careful not to touch the motorcycle mechanism when doing so. The motorcycle mechanism initialization operation will be performed automatically after the power is turned on.
-
- 8** Set the volume value on the INPUT ADJUSTMENT Screen in Game Test Mode. The recommended value for the accelerator volume is “30H±8H” with the accelerator released. Check to make sure the value increases when the accelerator is twisted. (See “9-3-5 INPUT ADJUSTMENT.”)

10-2-2 Replacing the Volume

A replacement volume (220-5753) and 3 heat-shrinkable tubes (310-5029-F20) are required. The following tools and soldering equipment will be used:

- Tamperproof screw wrench (for M4)
- Nipper
- Cutter
- Wire stripper
- Soldering iron
- Industrial dryer

1 Turn the power

2 Refer to Step 2 under “10-2-1 Adjusting the Volume” and remove the VR cover.

3 Remove the screw and take the volume off.

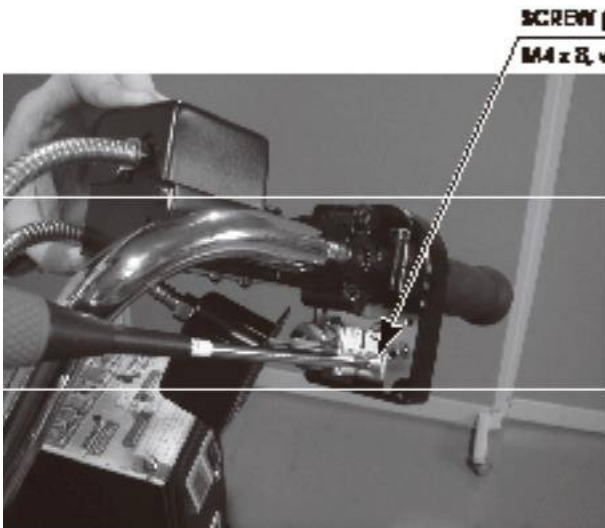

10-2-2 FIG. 01

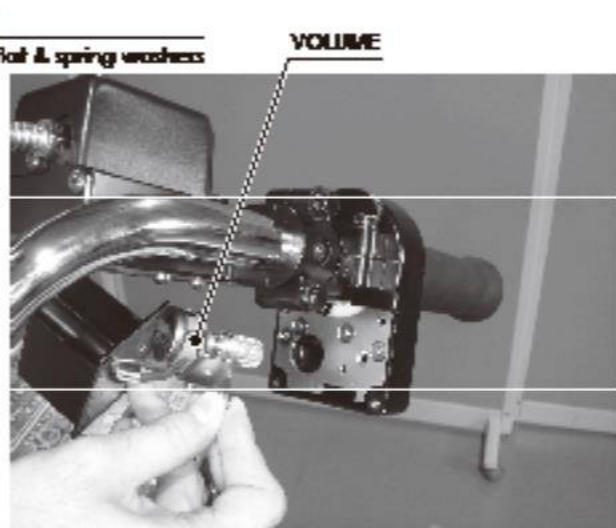

10-2-2 FIG. 02

4 Remove the 2 hexagon socket screws and pull the gear off the volume shaft.

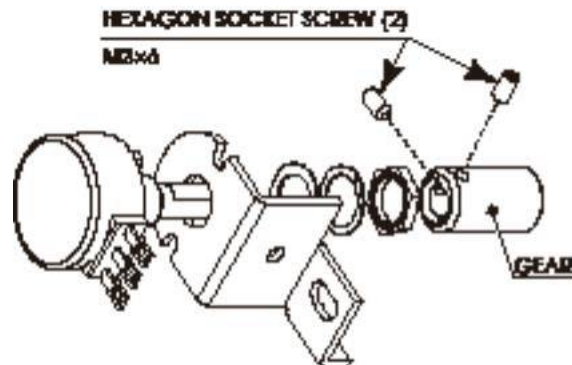

10-2-2 FIG. 03

5 Remove the nut fastening the VR bracket in place and take the volume off the VR bracket. (See 10-2-2 FIG. 03.)

-
- 6** The wires connected to the volume will proceed to be used. Use a tool such as nippers or a cutter to remove the old heat-shrinkable tubes from the places where the wires are connected.

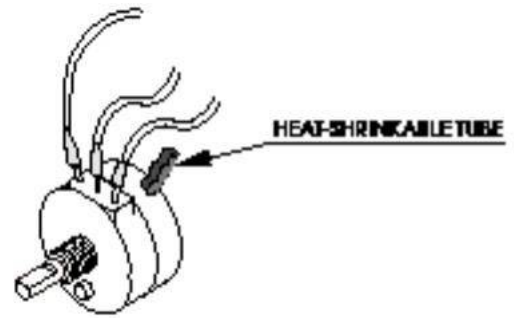

10-2-2 FIG. 04

7

Use a soldering iron to melt the solder and separate the wires from the old volume. Be careful when using the soldering iron.

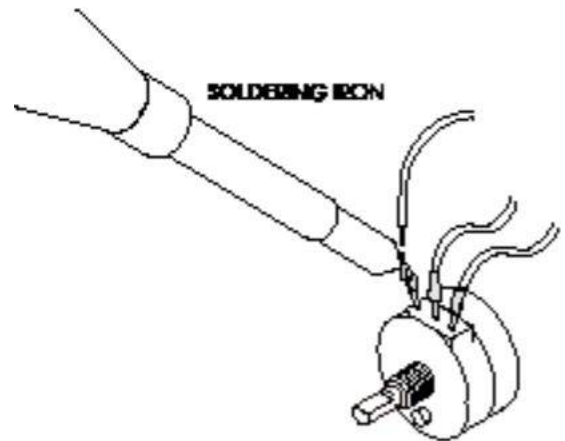

10-2-2 FIG. 05

-
- 8** If the exposed conductive wire at the end is less than 5 mm, use a tool such as a wire stripper or cutter to cut the coating back.
-
- 9** Pass the wires through the 3 heat-shrinkable tubes.
-
- 10** Solder the wires to the terminals on the new volume. Check the wiring diagram and be careful not to mix up the wires.
-
- 11** Cover the soldered parts with the heat-shrinkable tubes and apply heat with an industrial dryer until the heat-shrinkable tubes tightly cover the soldered parts.
-
- 12** Refer to Steps 3-5 and work in reverse order to attach the volume.
-
- 13** Refer to "10-2-1 Adjusting the Volume" and adjust the volume.

10-2-3 GREASING

STOP IMPORTANT

- Be sure to use the designated grease. Using undesignated grease can cause parts damage.
- Do not apply grease to locations other than as specified. Doing so may create a risk of operational problems and deterioration of parts.
- The designated periods for greasing serve only as a guide. Whenever there are squeaks or other anomalies, apply grease at designated locations.

Use spray grease once every three months to grease up the gear mesh portion of the constituent parts.

Use "Grease Mate" (part number 090-0066) for the spray grease.

Refer to Steps 1 and 2 under "10-2-1 Adjusting the Volume" and remove the VR cover. Apply grease between the gears that turn the volume shaft.

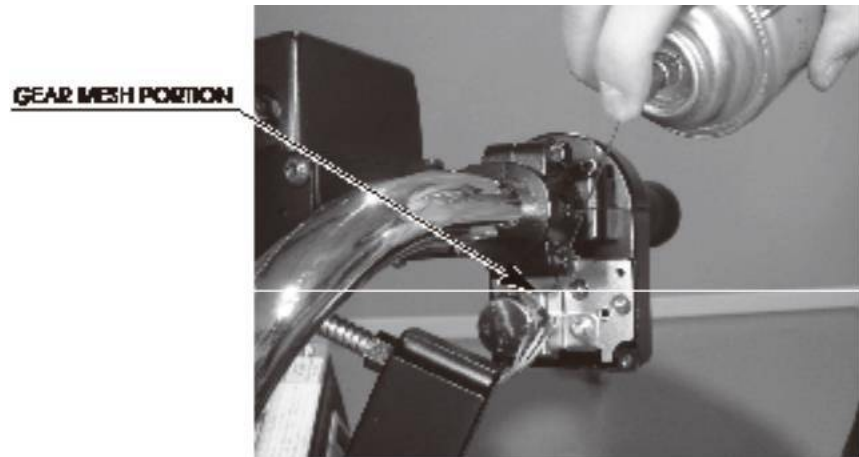

10-2-3 FIG. 01

10-3 HANDLE VOLUME

10-3-1 Adjusting the Volume

1 Turn the power

off. **2** Remove the 4 screws and take Handle Front Cover Lid B off.

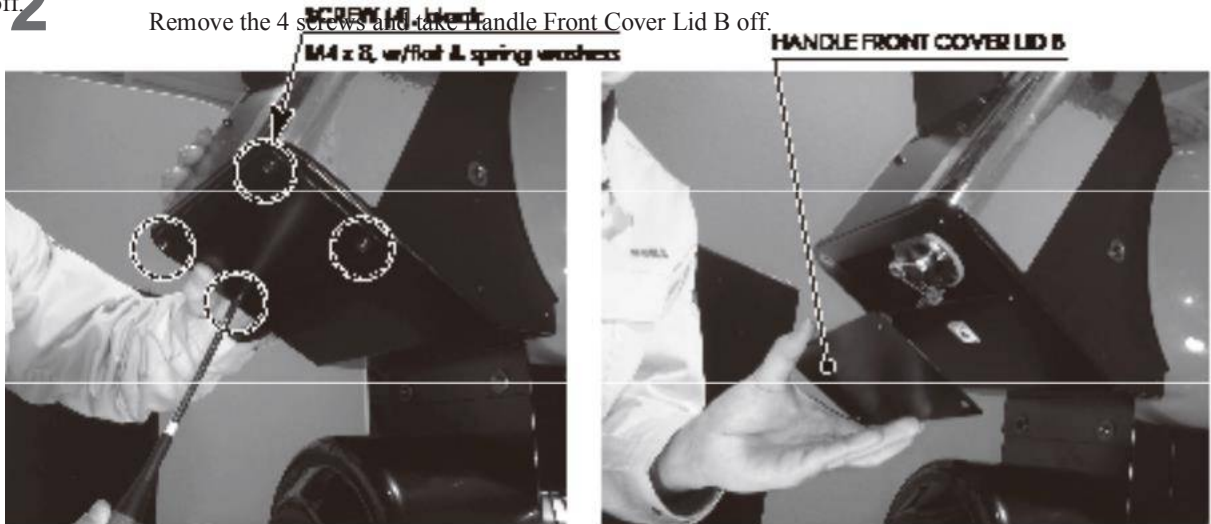

10-3-1 FIG. 01

10-3-1 FIG. 02

3 Loosen the 2 screws, move the VR bracket, and adjust the angle and way the gears fit together. The handle should be in the center position, and the D-cut surface of the volume rotating shaft should be in the position shown in the figure when doing so.

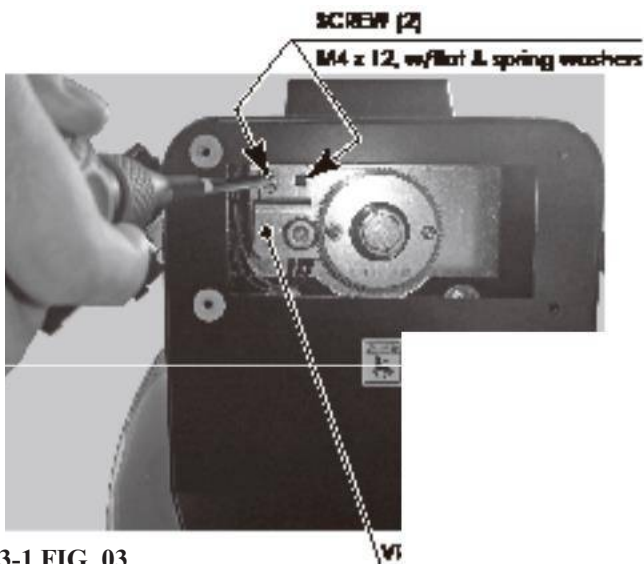

10-3-1 FIG. 03

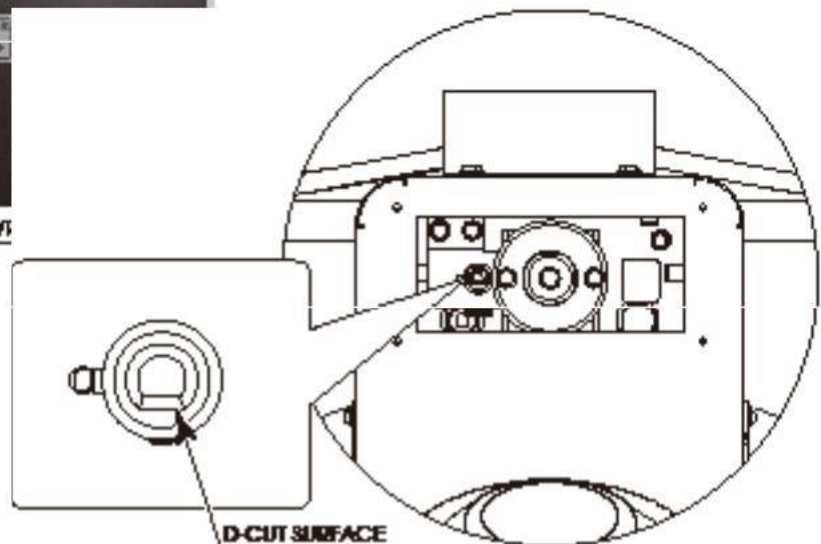

10-3-1 FIG. 04

4

After performing the adjustment, use the 2 screws to fully tighten the VR bracket on.

5

Operate the handle and check to make sure the gears rotate smoothly.

6

Refer to Step 2 and attach Handle Front Cover Lid B.

7

Turn on the power and be careful not to touch the motorcycle mechanism when doing so. The motorcycle mechanism initialization operation will be performed automatically after the power is turned on.

8

Set the volume value on the INPUT ADJUSTMENT Screen in Game Test Mode. The recommended value for the handle volume is “30H±8H” with the handle in the center position. Check to make sure the value decreases when the handle is turned to the left and increases when it is turned to the right. (See “9-3-5 INPUT ADJUSTMENT.”)

10-3-2 Replacing the Volume

A replacement volume (220-5753) and 3 heat-shrinkable tubes (310-5029-F20) are required. The following tools and soldering equipment will be used:

- Tamperproof screw wrench (for M4)
- Nipper
- Cutter
- Wire stripper
- Soldering iron
- Industrial dryer

1 Turn the power

2 Remove the 2 screws and take the handle front tube bracket off. Be careful not to damage the wires when doing so.

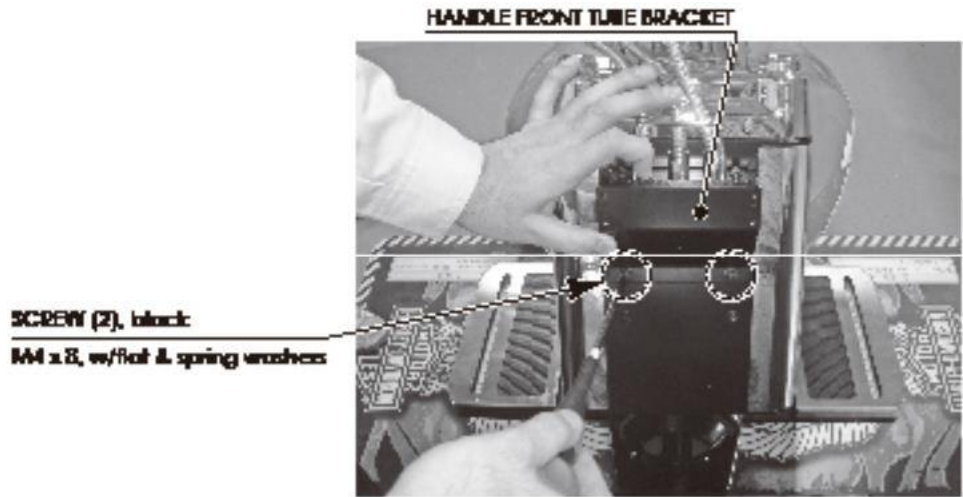

10-3-2 FIG. 01

3 Detach the 3 connectors

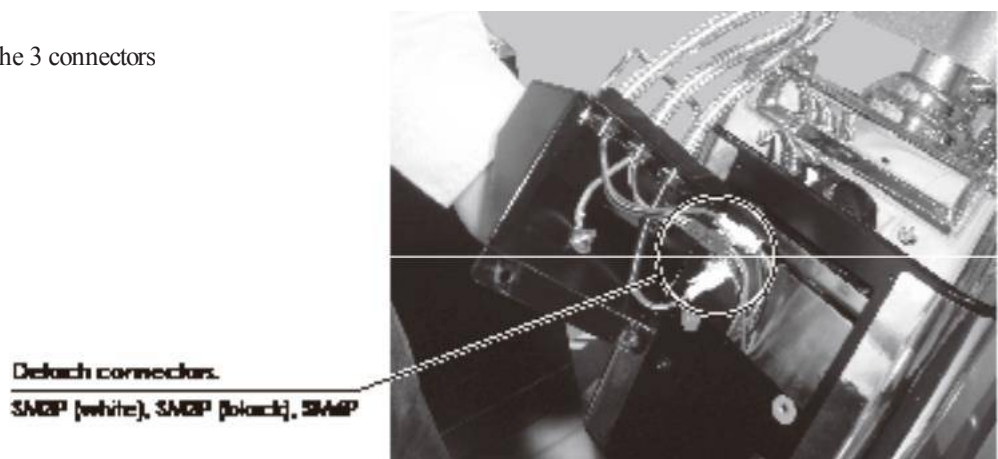

10-3-2 FIG. 02

4

Lay out a sheet of protective fabric and set the handle front tube bracket on top of it.

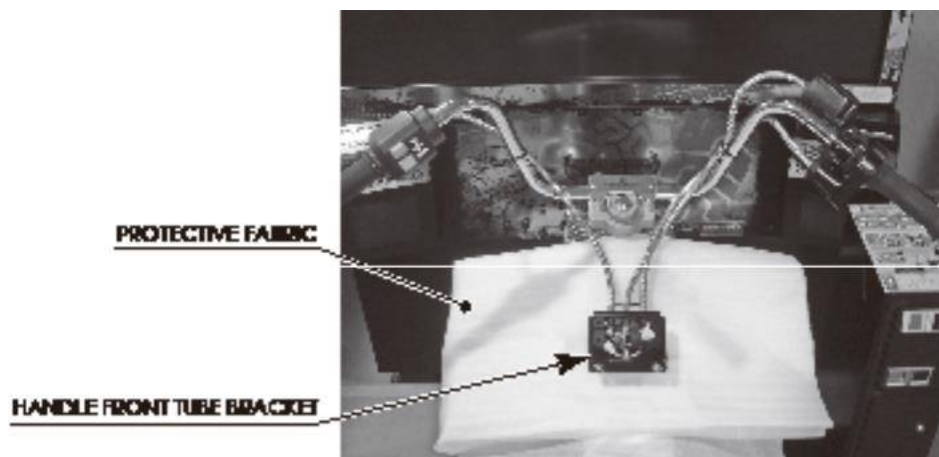

10-3-2 FIG. 03

5

Remove the 4 tamperproof screws.

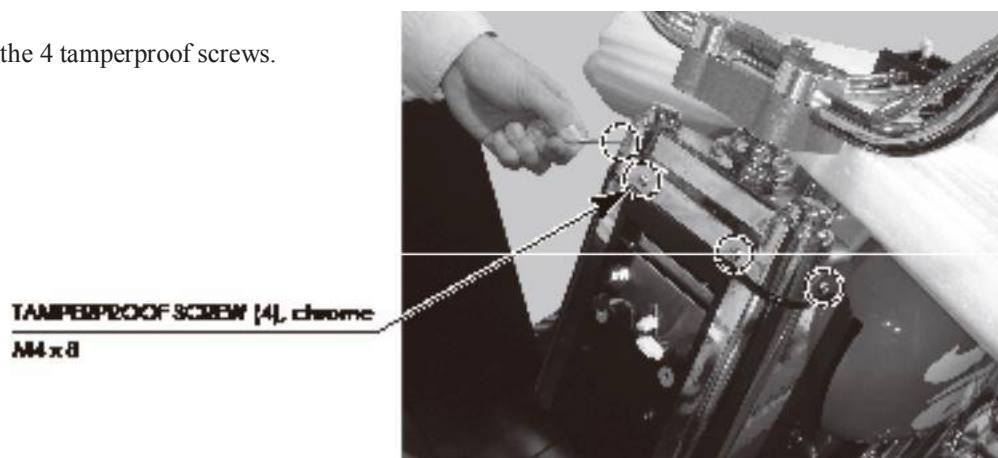

10-3-2 FIG. 04

6

Remove the 4 tamperproof screws and take Handle Front Cover Lid A off.

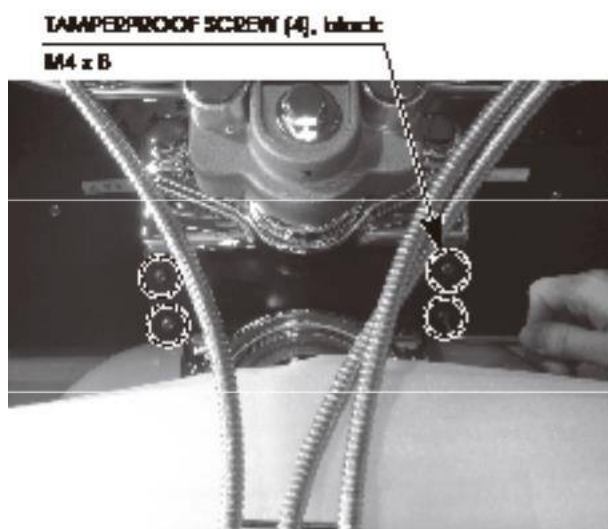

10-3-2 FIG. 05

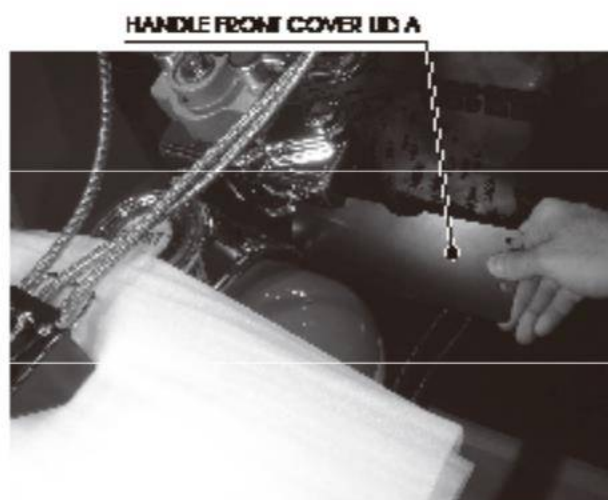

10-3-2 FIG. 06

7

Remove the 6 screws and take the handle front cover off. Be careful not to damage the wires when doing so.

SCREW (2), black
M4 x 10, w/flat & spring washers,
large flat washer used

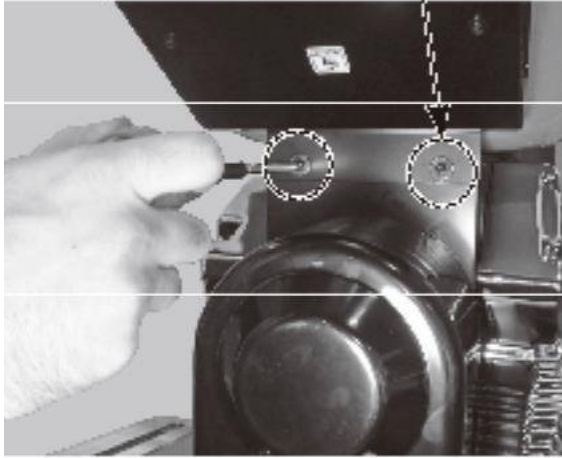

10-3-2 FIG. 07

SCREW (4), black
M4 x 10, w/flat & spring washers,
large flat washer used



10-3-2 FIG. 08

HANDLE FRONT COVER

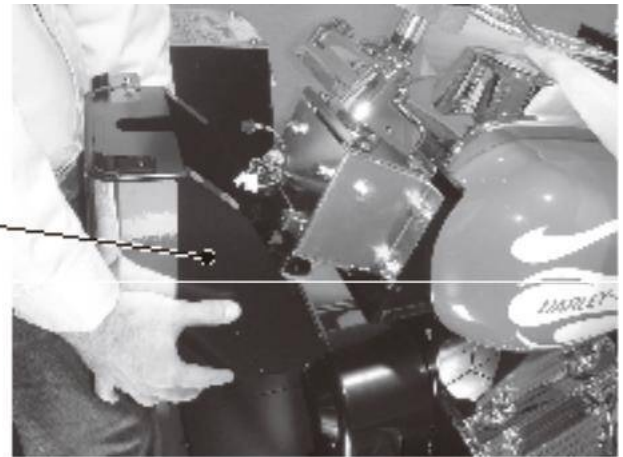

10-3-2 FIG. 09

8

Remove the 2 screws and take the volume off.

SCREW (2)
x 12, w/flat & spring washers

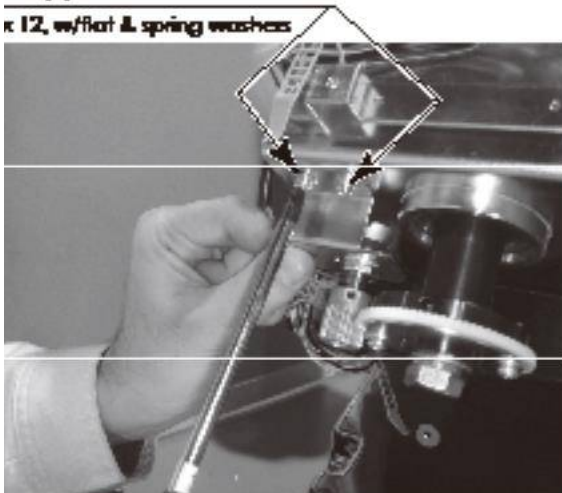

10-3-2 FIG. 10

VOLUME



10-3-2 FIG. 11

9

Remove the 2 hexagon socket screws and pull the gear off the volume shaft.

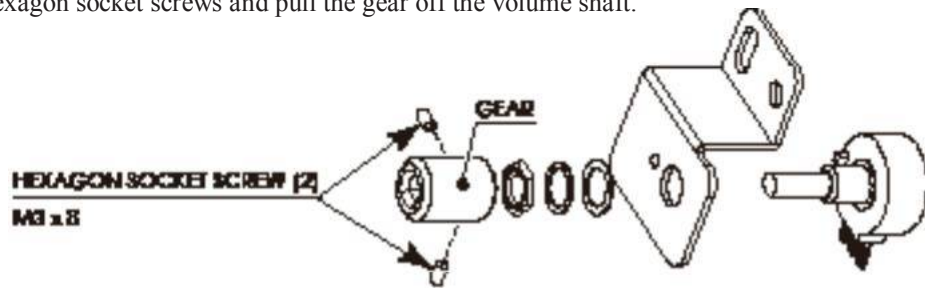

10-3-2 FIG. 12

10

Remove the nut fastening the VR bracket in place and take the volume off the VR bracket. (See 10-3-2 FIG. 03.)

11

The wires connected to the volume will proceed to be used. Use a tool such as nippers or a cutter to remove the old heat-shrinkable tubes from the places where the wires are connected.

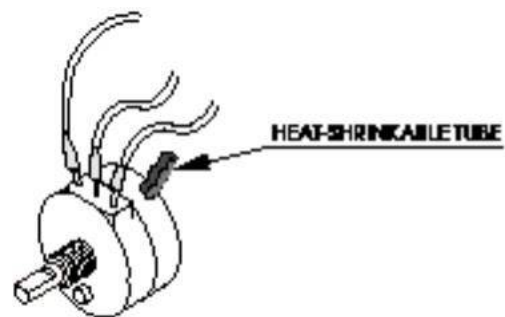

10-3-2 FIG. 13

12

Use a soldering iron to melt the solder and separate the wires from the old volume. Be very careful when using the soldering iron.

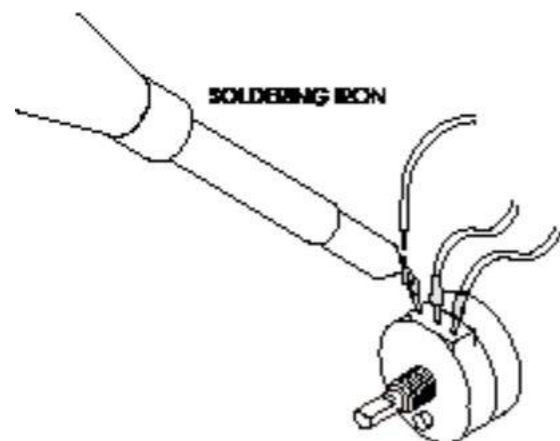

10-3-2 FIG. 14

13

If the exposed conductive wire at the end is less than 5 mm, use a tool such as a wire stripper or cutter to cut the coating back.

14

Pass the wires through the 3 heat-shrinkable tubes.

15 Solder the wires to the terminals on the new volume. Check the wiring diagram and be careful not to mix up the wires.

16 Cover the soldered parts with the heat-shrinkable tubes and apply heat with an industrial dryer until the heat-shrinkable tubes tightly cover the soldered parts.

17 Refer to Steps 2-10 and work in reverse order to attach the volume, handle front tube bracket, Handle Front Cover Lid A, and handle front cover.

18 Refer to “10-3-1 Adjusting the Volume” and adjust the volume.

10-3-3 GREASING

STOP IMPORTANT

- Be sure to use the designated grease. Using undesig-nated grease can cause parts damage.
- Do not apply grease to locations other than as specified. Doing so may create a risk of operational problems and deterioration of parts.
- The designated periods for greasing serve only as a guide. Whenever there are squeaks or other anomalies, apply grease at designated locations.

Use spray grease once every three months to grease up the gear mesh portion of the constituent parts. Use "Grease Mate" (part number 090-0066) for the spray grease. Refer to Steps 1 and 2 under "10-3-1 Adjusting the Volume" and remove Handle Front Cover Lid B. Apply grease between the gears that turn the volume shaft.



10-3-3 FIG. 01

11 MOTORCYCLE MECHANISM

⚠ WARNING

- Always disengage the power before beginning work. Otherwise there could be an electric shock or short circuit. Note that when using TEST mode there will be electricity running through the machine. Do not touch any parts that are not specified in these directions.
- Be careful not to damage the wires. Damaged wires may cause electric shock or short circuit or present a fire risk.
- Be very careful when soldering. Handling a soldering iron carelessly may result in a fire or a burn.

1-1 ROLL (LEAN) VOLUME

11-1-1 Adjusting the Volume

1

Turn the power

2

Remove the 6 truss screws and take the front shaft cover off.

TRUSS SCREW (6), black
M4 x 8, large flat washer used



11-1-1 FIG. 01

FRONT SHAFT COVER

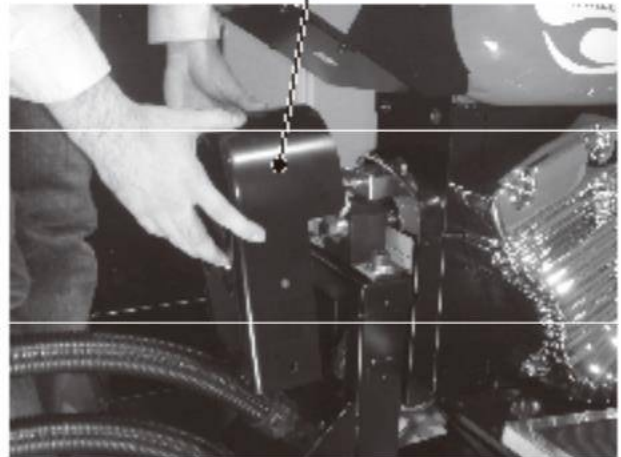

11-1-1 FIG. 02

- 3 Loosen the 2 screws, move the VR bracket, and adjust the angle and way the gears fit together. The motorcycle mechanism should be in the center position, and the D-cut surface of the volume rotating shaft should be in the position shown in the figure when doing so.

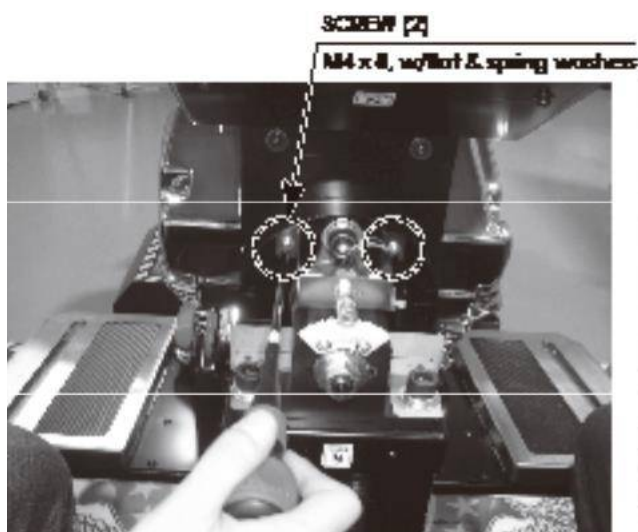

11-1-1 FIG. 03

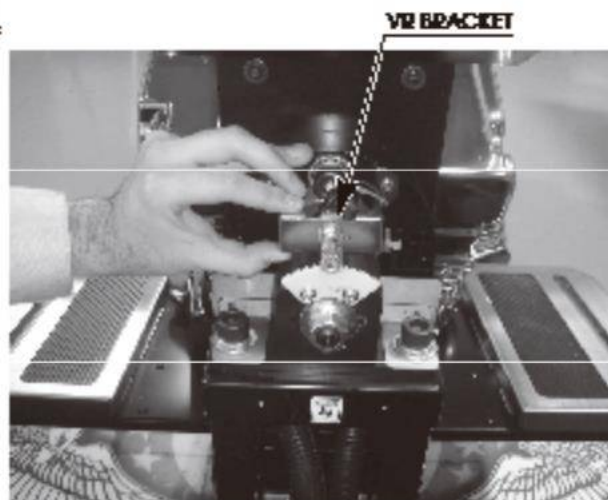

11-1-1 FIG. 04

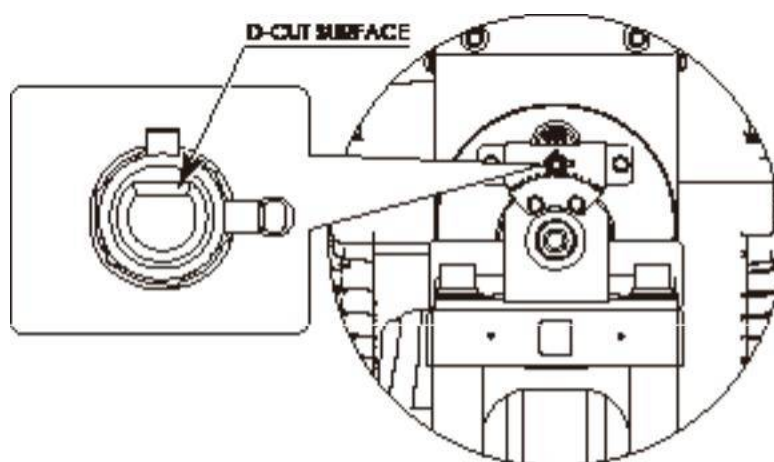

11-1-1 FIG. 05

- 4 After performing the adjustment, use the 2 screws to fully tighten the VR bracket on.
- 5 Refer to Step 2 and attach the front shaft cover.
- 6 Operate the motorcycle mechanism and check to make sure the gears rotate smoothly.
- 7 Turn on the power and be careful not to touch the motorcycle mechanism when doing so. The motorcycle mechanism initialization operation will be performed automatically after the power is turned on.
- 8 Set the volume value on the INPUT ADJUSTMENT Screen in Game Test Mode. The recommended value for the roll volume is “80H±8H” with the motorcycle mechanism in the center position. Check to make sure the value decreases when the motorcycle mechanism is tilted to the right and increases when it is tilted to the left. (See “9-3-2 INPUT TEST.”)

11-1-2 Replacing the Volume

A replacement volume (220-5753) and 3 heat-shrinkable tubes (310-5029-F20) are required. The following tools and soldering equipment will be used:

- Tamperproof screw wrench (for M4)
- Nipper
- Cutter
- Wire stripper
- Soldering iron
- Industrial dryer

1 Turn the power

2 Refer to “11-1-1 Adjusting the Volume” and remove the front shaft cover.

3 Undo the cord clamp.

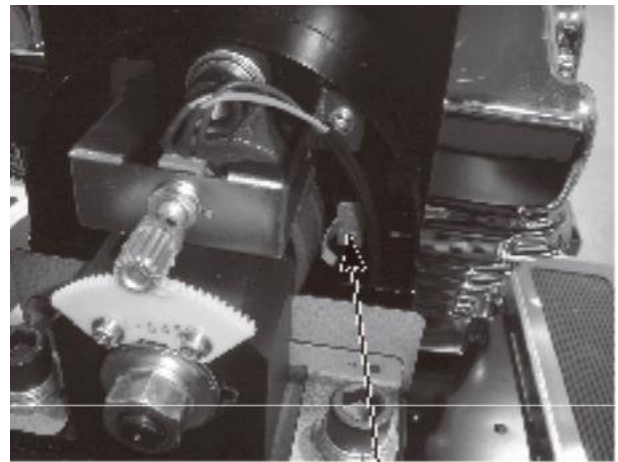

11-1-2 FIG. 01

Undo cord clamp.

(1)

4 Remove the 2 screws and take the volume off. Be careful not to drop or lose the screws when doing so.

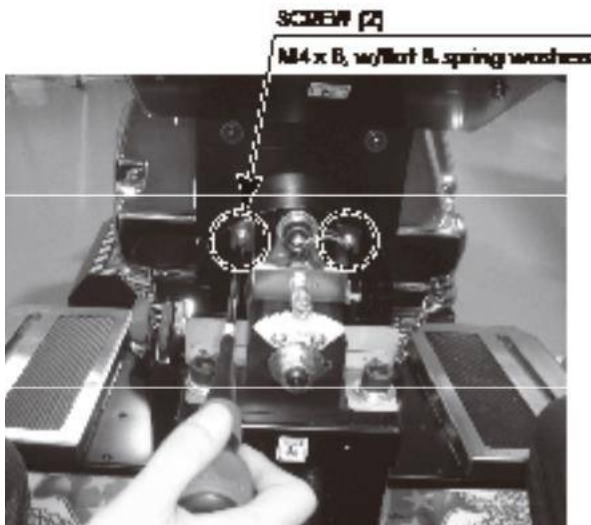

11-1-2 FIG. 02



11-1-2 FIG. 03

5

Remove the 2 hexagon socket screws and pull the gear off the volume shaft.

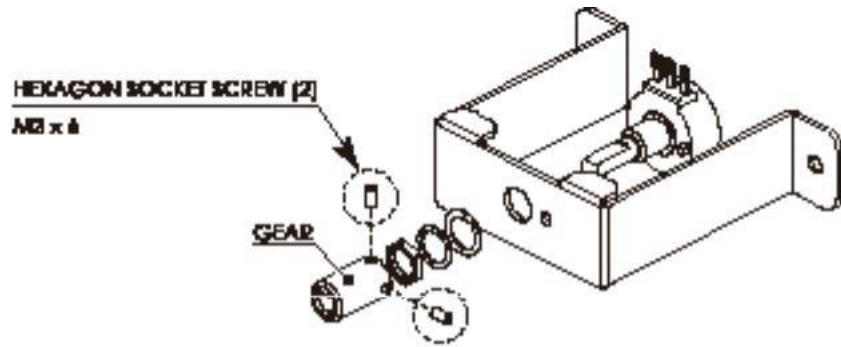

11-1-2 FIG. 04

6

Remove the nut fastening the VR bracket in place and take the volume off the VR bracket. (See 11-1-2 FIG. 04.)

7

The wires connected to the volume will proceed to be used. Use a tool such as nippers or a cutter to remove the old heat-shrinkable tubes from the places where the wires are connected.

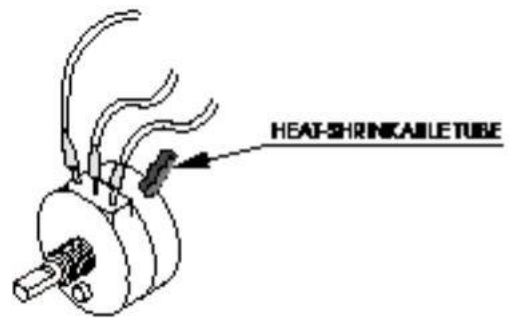

11-1-2 FIG. 05

8

Use a soldering iron to melt the solder and separate the wires from the old volume. Be very careful when using the soldering iron.

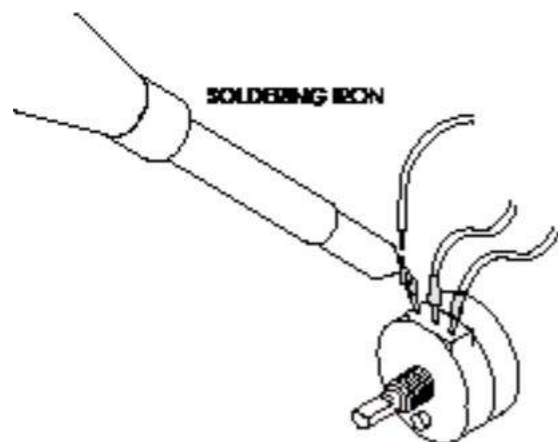

11-1-2 FIG. 06

-
- 9** If the exposed conductive wire at the end is less than 5 mm, use a tool such as a wire stripper or cutter to cut the coating back.
-
- 10** Pass the wires through the 3 heat-shrinkable tubes.
-
- 11** Solder the wires to the terminals on the new volume. Check the wiring diagram and be careful not to mix up the wires.
-
- 12** Cover the soldered parts with the heat-shrinkable tubes and apply heat with an industrial dryer until the heat-shrinkable tubes tightly cover the soldered parts.
-
- 13** Refer to Steps 3-6 and work in reverse order to attach the volume.
-
- 14** Refer to “11-1-1 Adjusting the Volume” and check the volume.
-

11-1-3 GREASING

STOP IMPORTANT

- Be sure to use the designated grease. Using undesignated grease can cause parts damage.
- Do not apply grease to locations other than as specified. Doing so may create a risk of operational problems and deterioration of parts.
- The designated periods for greasing serve only as a guide. Whenever there are squeaks or other anomalies, apply grease at designated locations.

Use spray grease once every three months to grease up the gear mesh portion of the constituent parts.

Use "Grease Mate" (part number 090-0066) for the spray grease.

Refer to Steps 1 and 2 under "11-1-1 Adjusting the Volume" and remove the front shaft cover. Apply grease between the gears that turn the volume shaft.



11-1-3 FIG. 01

11-2 REPLACING THE SIDE GUIDE PLATES

The side guide plates are important parts which prevent accidents. Always inspect them before the doors open every day to make sure they are not damaged and have not come off. If the game is played despite the side guide plates being damaged or having come off, it could result in an accident such as the customer getting his or her fingers caught.

The following work requires a hexagon wrench with a WAF of 2.5 mm.

1 Turn the power off.

2 Remove the 2 hexagon socket screws and take the side guide plate off.

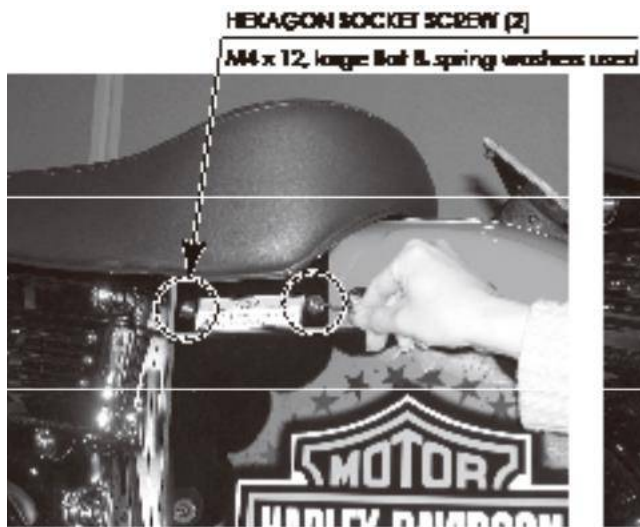

11-2 FIG. 01



11-2 FIG. 02

3 Affix STICKER W PINCH HLT ENG to the new side guide plate as shown in the figure.

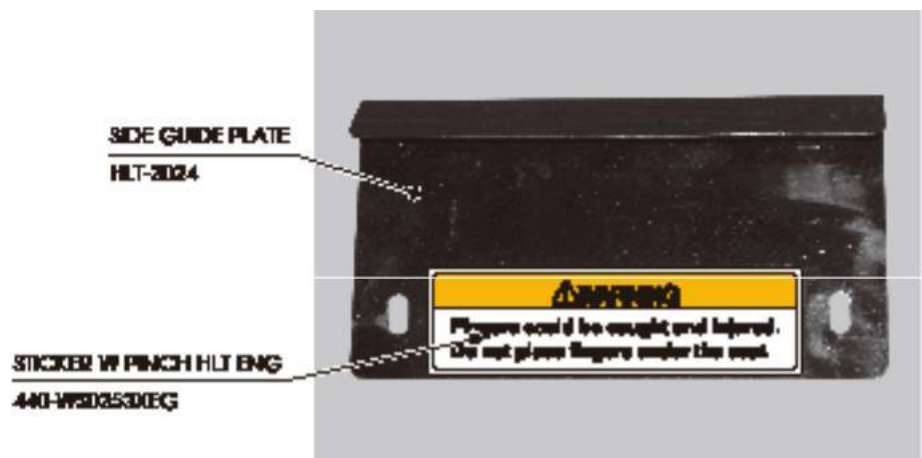

11-2 FIG. 03

4

Use the 2 hexagon socket screws to loosely attach the new side guide plate.

HEXAGON SOCKET SCREW (2)
M4 x 12, large flat & spring washers used

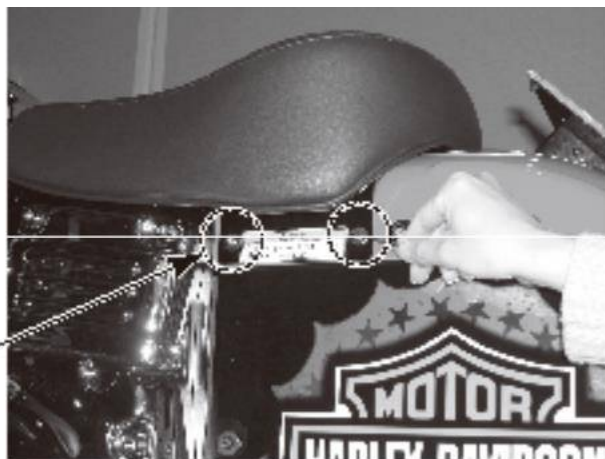

11-2 FIG. 04

5

Adjust the side guide plate so that the clearance between it and the seat is about 1 mm, and fully tighten the 2 hexagon socket screws.

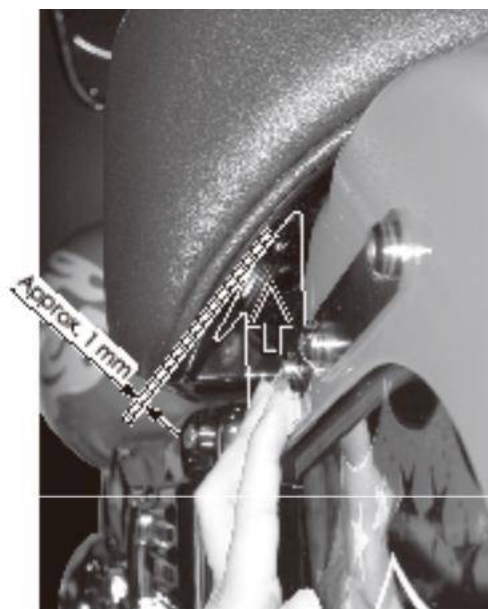

11-2 FIG. 05

6

Refer to Steps 1-5 and replace the plate on the other side following the same procedure.

11-3 REPLACING THE VIBRATION UNIT HARNESS

If the motorcycle mechanism does not vibrate, replace the vibration unit harness. If that does not fix it, replace the vibration unit itself.

The following work requires nippers and a hexagon wrench with a WAF of 2.5 mm.

1 Turn the power

2 of Remove the 6 hexagon socket screws and take the switch plate off. Be careful not to damage the wires when doing so.

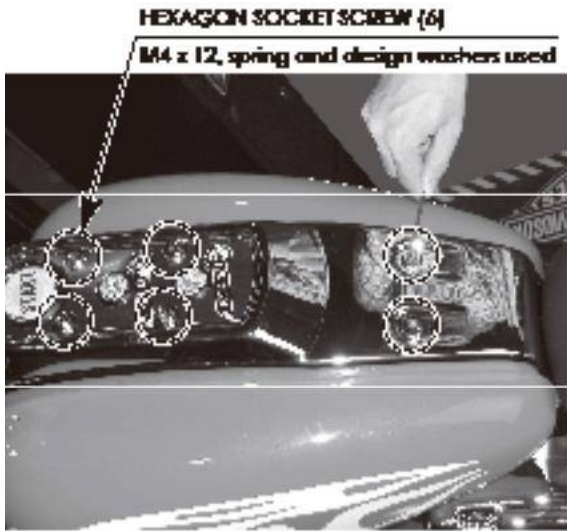

11-3 FIG. 01

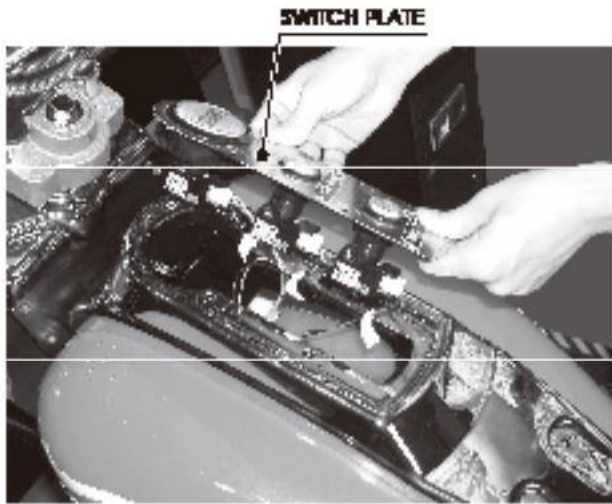

11-3 FIG. 02

3 Detach the connector and remove the switch plate.

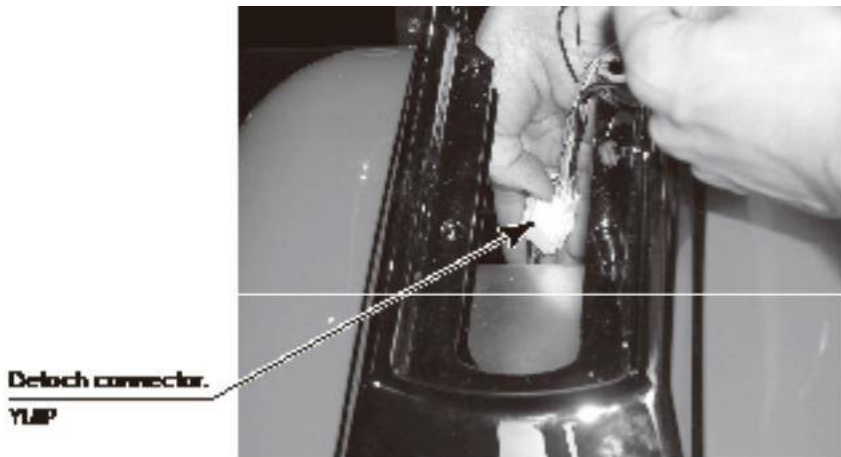

11-3 FIG. 03

4

Take Tank Center

off.

TANK CENTER



11-3 FIG. 04

5

Remove the 4 screws and take Tank L off.

SCREW (4), black

MMx12, w/spring washer, large flat washer used

TANK L

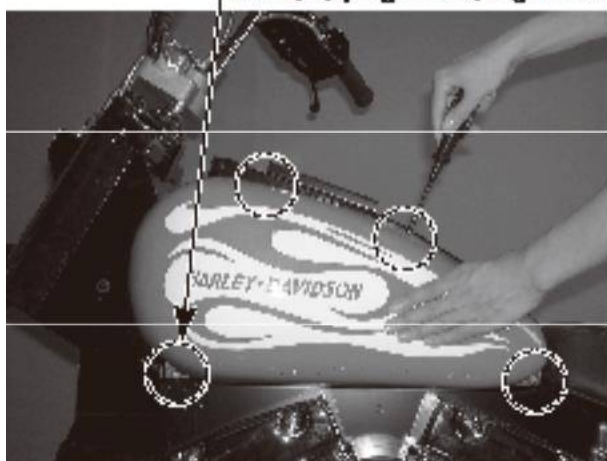

11-3 FIG. 05

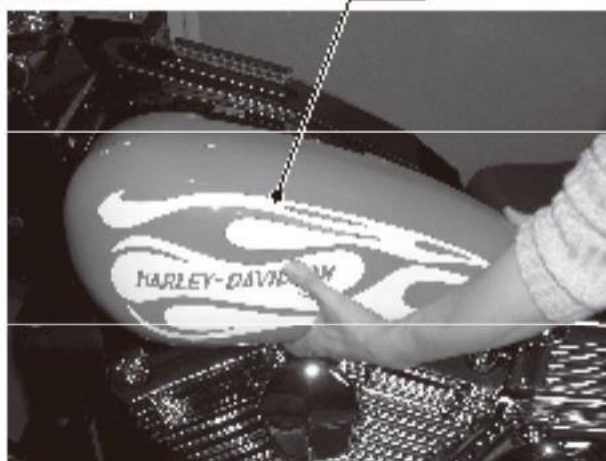

11-3 FIG. 06

6

Refer to Step 5 and take Tank R off.

7

Using the nippers, cut the cable tie. Be careful not to damage the wires when doing so.

CABLE TIE



11-3 FIG. 07

NOTE: When attaching it, use 2 cable ties that have been joined together to fasten the core and wires together. Cut the extra part of the cable tie off. Be careful not to damage the wires when doing so.

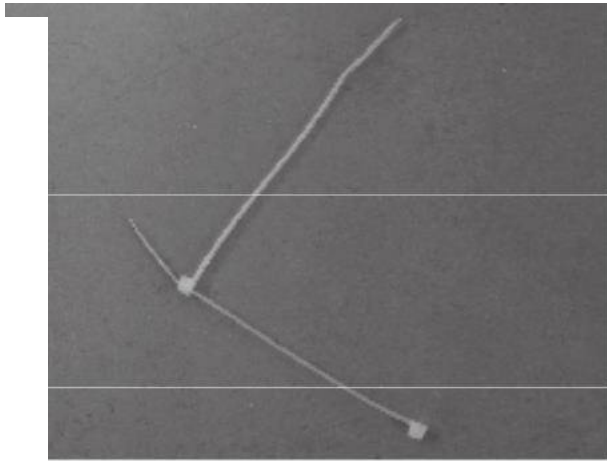

11-3 FIG. 08

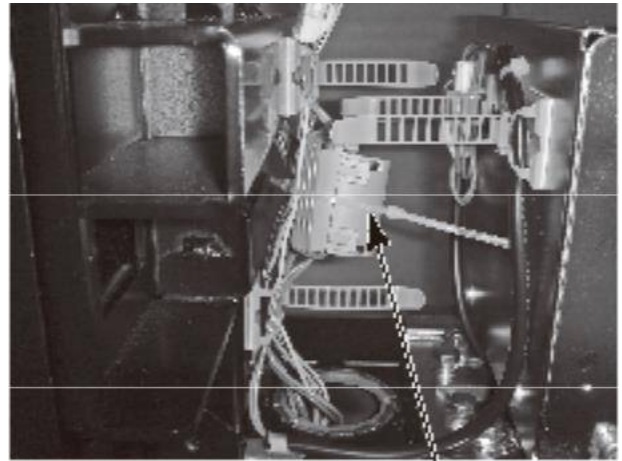

11-3 FIG. 09

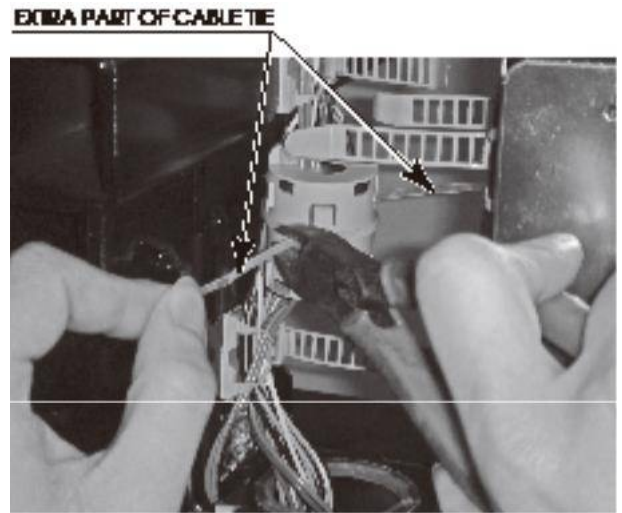

11-3 FIG. 10

8

Undo the 3 cord clamps

Undo cord clamps.

24

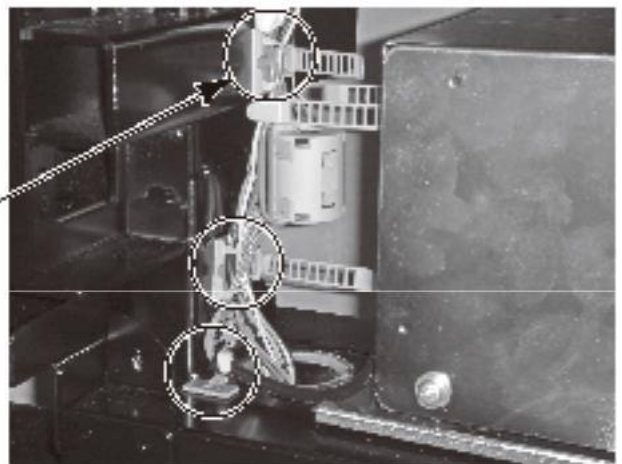

11-3 FIG. 11

9

Detach the

connector.

Detach connectors.
YLZP

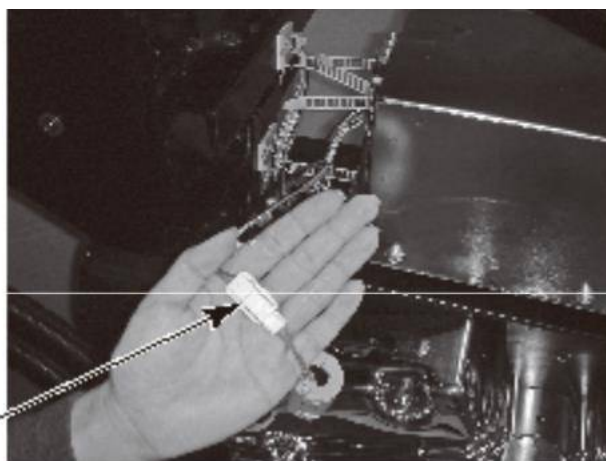

11-3 FIG. 12

10

Remove the 4 hexagon bolts and take the vibration unit off.

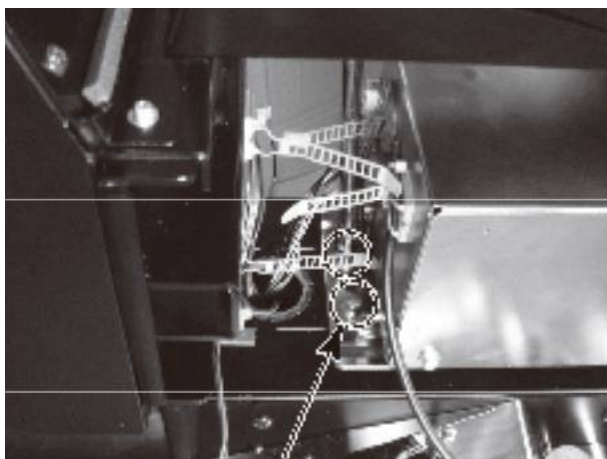

11-3 FIG. 13

HEXAGON BOLT (4)
Nut, washer & spring washers

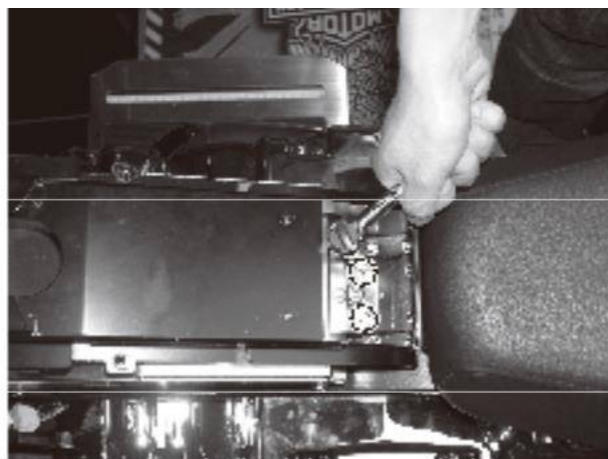

11-3 FIG. 14

VIBRATION UNIT

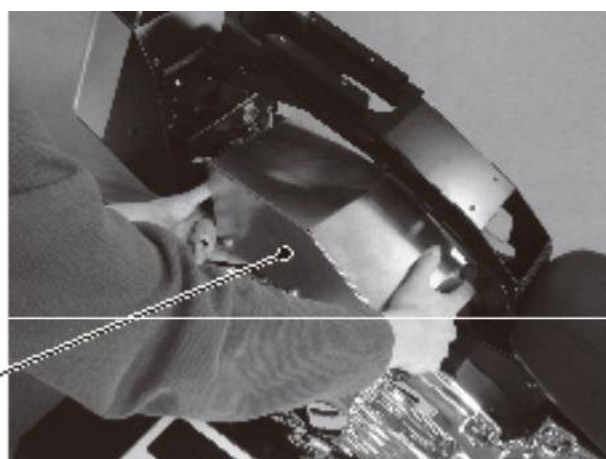

11-3 FIG. 15

11 Set the vibration unit on a level surface.

12 Undo the clamps and open the core.

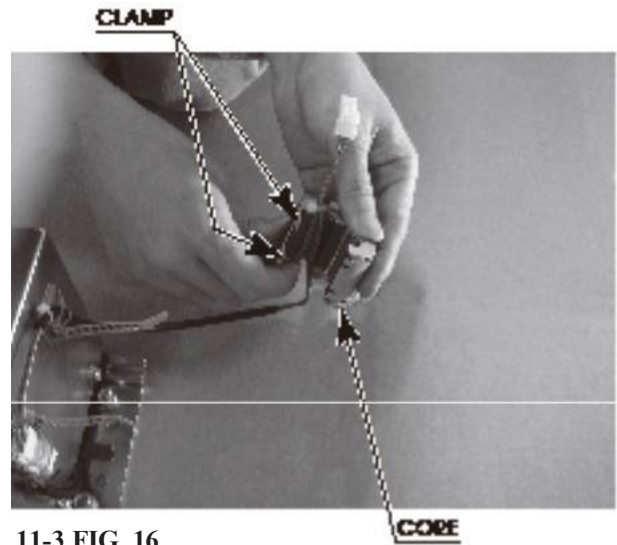

11-3 FIG. 16

13 Use the nippers to cut the cable tie, and take the core out. Be careful not to damage the wires when doing so. When attaching it, wrap the wires around the core 2.5 times and fasten them to it using a cable tie.

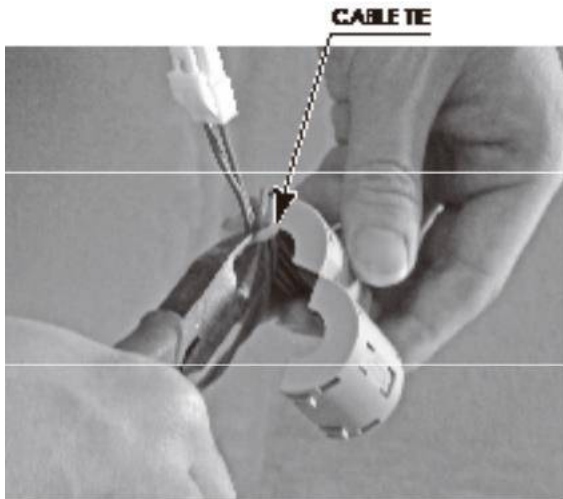

11-3 FIG. 17

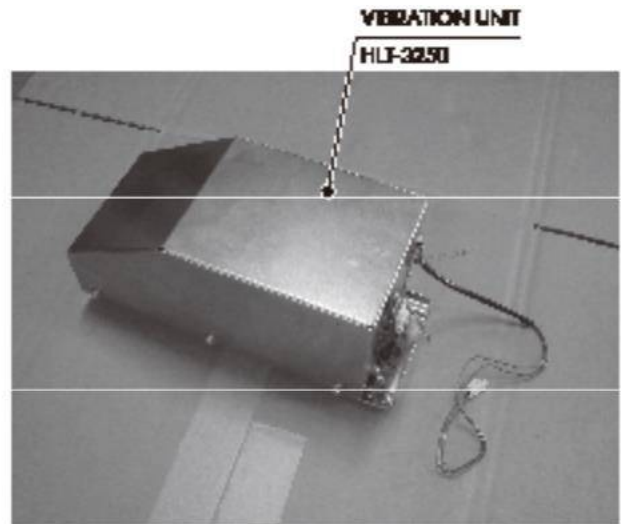

11-3 FIG. 18

14 Undo the 2 cord clamps.

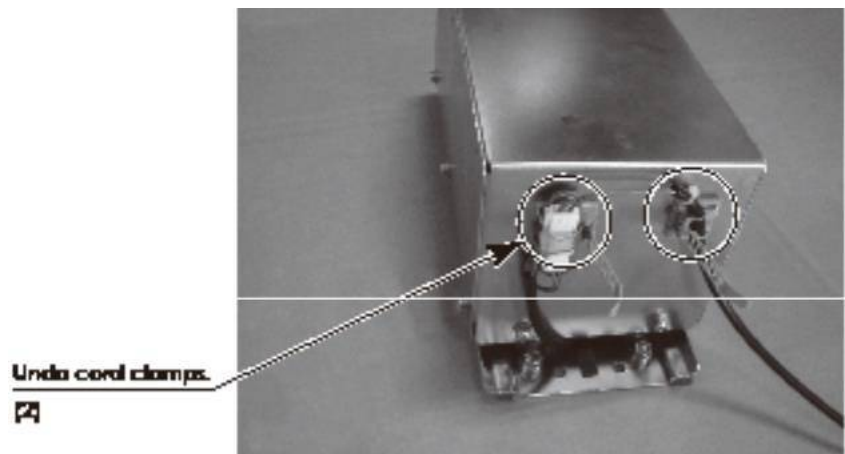

11-3 FIG. 19

15

Detach the connector and replace the vibration unit harness.

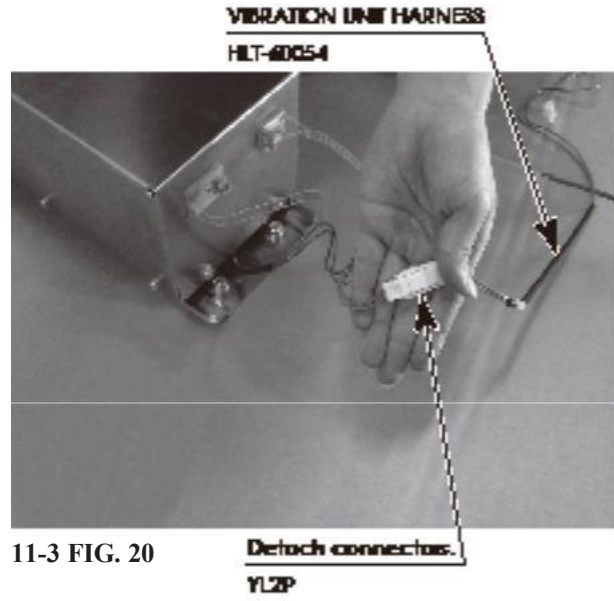

11-3 FIG. 20

12 COIN SELECTOR

2-1 CLEANING THE COIN SELECTOR

TOP IMPORTANT

- Remove and clean smears by using a soft cloth dipped in water or diluted chemical detergent and then squeezed dry.
- Never apply machine oil, etc. to the Coin Selector.
- After cleaning the Coin Selector, insert a regular coin in the normal working status and ensure that the Selector correctly functions.

The Coin Selector should be cleaned once a month. When cleaning, follow the procedure below:

1 Turn the power off.

2 Unlock the coin chute door with the master key and open it.



12-1 FIG. 01

3

Open the gate and dust off by using a soft brush. Remove and clean smears by using a soft cloth dipped in water or diluted chemical detergent and then squeezed dry.

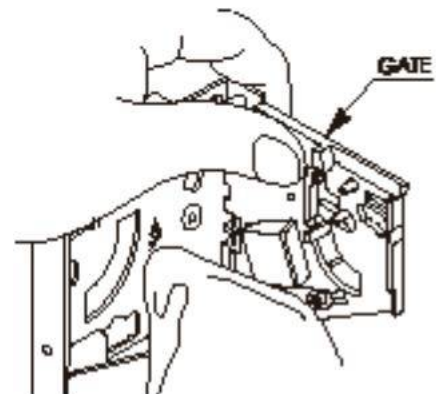

12-1 FIG. 02

-
- 4** Remove the cradle. When removing the retaining ring (E ring), be very careful so as not to bend the rotary shaft.

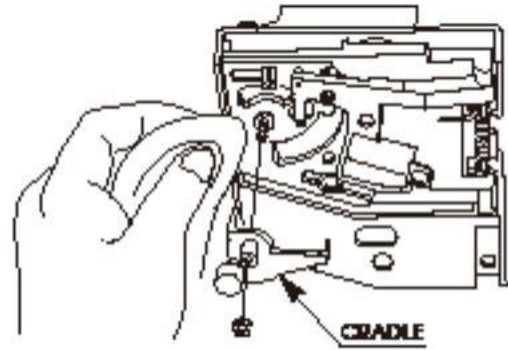

12-1 FIG. 03

-
- 5** Remove stain from the rotary shaft and shaft receiving portions by wiping off with a soft cloth, etc.

-
- 6** After wiping off dirt, wipe away moisture with a dry cloth and make sure that the coin selector is completely dry.

12-2 HANDLING THE COIN JAM

If the coin is not rejected when the REJECT button is pressed, open the coin chute door and open the selector gate. After removing the jammed coin, put a normal coin in and check to see that the selector correctly functions.

2-3 COIN INSERTION TEST

Once every month, when performing the Coin SW Test, simultaneously check the following:

- Does the Coin Meter count satisfactorily?
- Does the coin drop into the Cashbox correctly?
- Is the coin rejected when inserted while keeping the Reject Button pressed down?
- Are extra coins and incorrect coins properly returned?

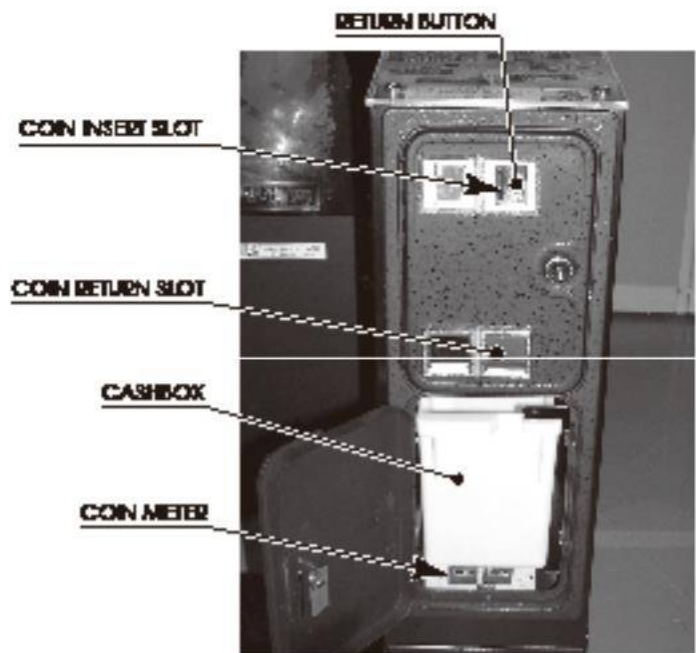

12-3 FIG. 01

13 DLP PROJECTOR

CAUTION

The DLP projector is adjusted prior to leaving the factory. Avoid any unnecessary adjustment. Failure to observe this can have a bad influence upon the players' or the customers' physical conditions.

IMPORTANT

- If the adjustment method in this manual does not resolve the problem contact the office listed in this manual or your supplier.
- “Snow” on the screen/changes in brightness for a short period are due to the high pressure mercury lamp in the projector. This is not a defect and does not need repairs.
- The life of the high pressure mercury lamp is the average number of hours 50% of lamps last for. Therefore a life of 8,000 hours does not mean that the lamp cannot last beyond 8,000 hours.
- There is no way of knowing when the lamp is going to cease to function. Once it ceases to function, the DLP projector will be unable to display anything and the product cannot be used. Have a spare lamp ready at all times.
- Do not stick tape, stickers or anything else onto the screen. Any kind of adhesive may damage the surface of the screen.

The projector remembers adjustments.

If there is any distortion, etc. that requires adjustment on the TEST screen, use the remote control.

The average life of the projector's high pressure mercury lamp is approximately 8,000 hours (50 % survival).

However this may change depending on circumstances.

The lamp will not last forever. If the screen is dark or continually disappears the lamp must be changed immediately.

After changing the projector lamp you must reset the timer setting.

13-1 CLEANING THE SCREEN

OP IMPORTANT

Since the Projector screen is susceptible to damage, pay careful attention to its handling. Do not clean the screen with volatile chemicals, solvents or alkaline/acidic cleaners.

Clean the screen surface once a week.

Dip a soft cloth in water 40 degrees centigrade or below, wring it out firmly, and use it to gently wipe the screen.

If there are stains that can't be removed with warm water, use a neutral detergent diluted to 2-3%.

Refrain from using other chemicals, solvents, bleaches and cleaners because they may affect the screen.

Also do not use chemically-treated cloths.

The screen is easily damaged, so avoid scratching it with hard objects or striking it with a duster or other objects.

If the stains are serious, contact the office detailed in this manual or the point-of-purchase for this product.

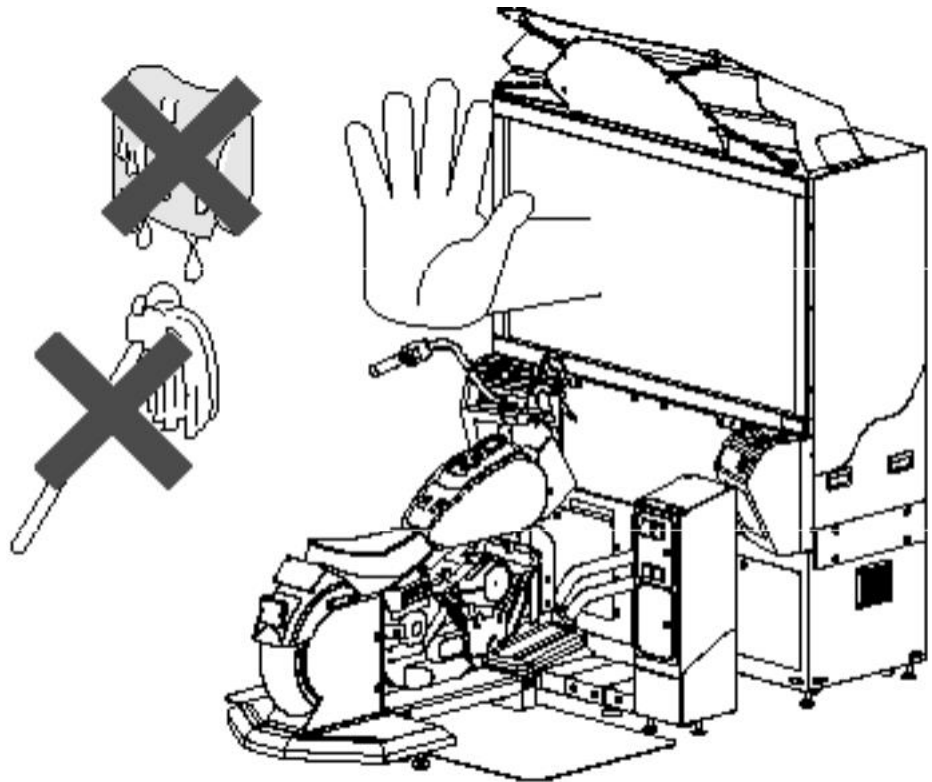

13-1 FIG. 01

14 REPLACING THE FLUORESCENT AND HALOGEN LAMPS

⚠ WARNING

- When working with the product, be sure to turn the power off. Working with the power on may cause an electric shock or short circuit.
- There is danger that hot lamps can cause burns. Exercise due caution when replacing lamps.
- Use lamps of the specified ratings. Using lamps with different ratings may cause fires or damage.
- Such things as deteriorated insulation in lighting fixtures can cause a short circuit and/or smoke. Make sure there are no abnormalities. For example, check if you can smell anything burning, if any sockets have been discolored and if the lamp has to be replaced frequently.

⚠ CAUTION

- To perform work safely and securely, be sure to prepare a step which is in a secure and stable condition. Performing work without using the step can cause violent falling down accidents.
- Be careful when handling the plastic made parts. Failure to observe this may cause injury due to damage or fragments resulting from damage.

14-1 REPLACING THE FLUORESCENT LAMP

1

Remove the 4 marquee screws, and take marquee off.

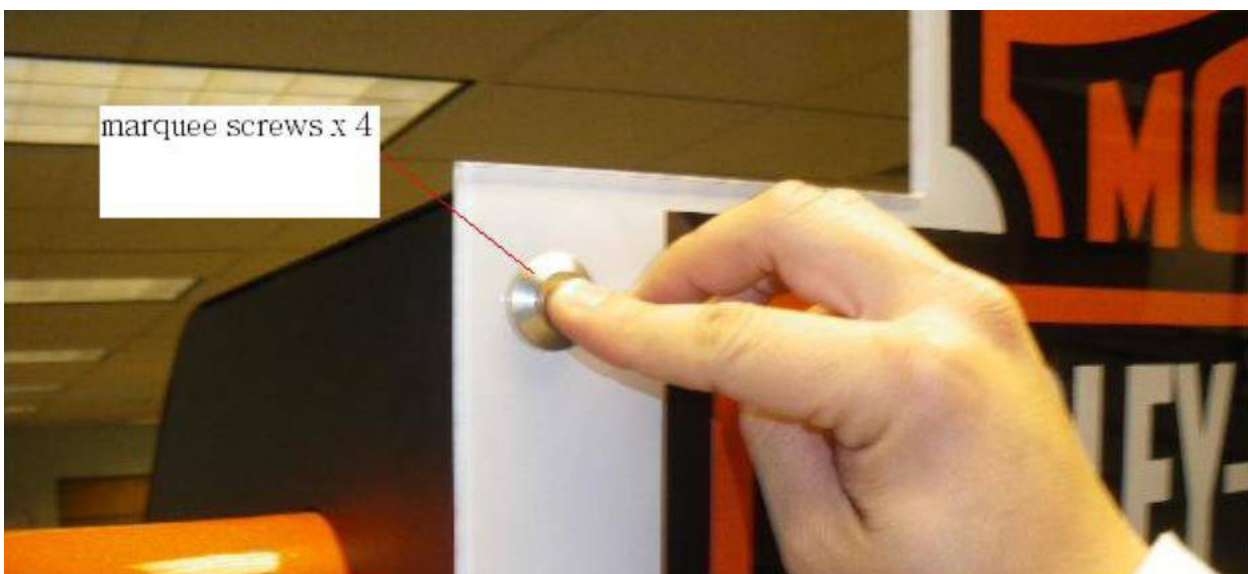

2

Carefully Replace Fluorescent lamp..

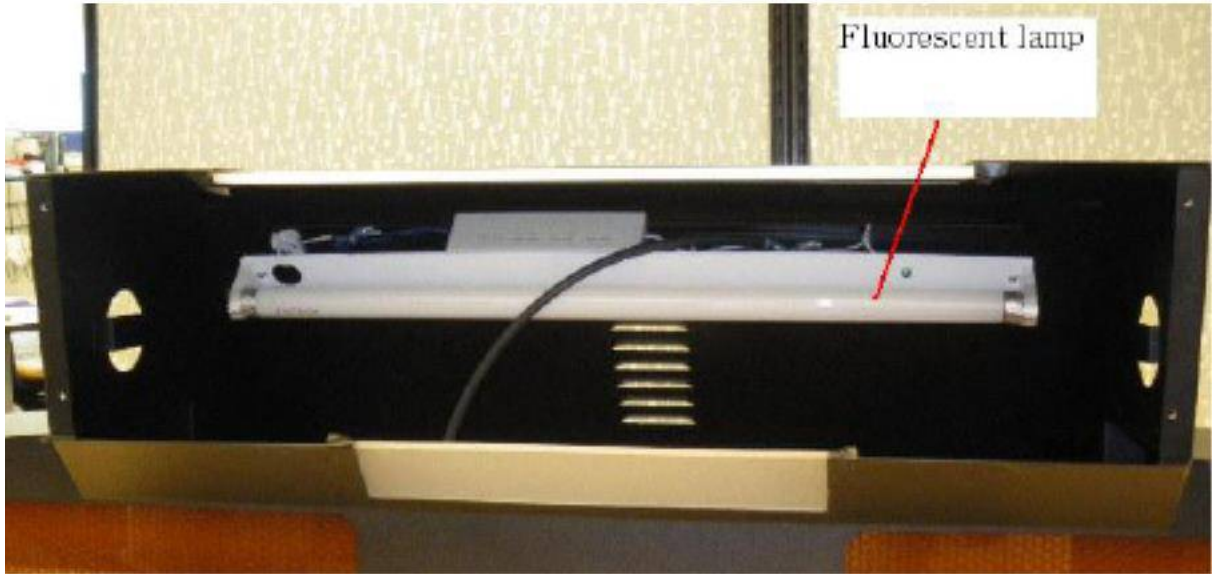

15 PERIODIC INSPECTION

⚠ WARNING

- Be sure to check once a year to see whether power cords are damaged, the plug is securely inserted, dust has accumulated between the socket outlet and the power plug, etc. Using the product with accumulated dust can cause fire and electric shock.
- Periodically, around once a year, get in touch with the office herein stated or the distributor, etc. where the product was purchased from, regarding internal cleaning. Using the product with accumulated dust in the interior can cause a fire or accident. Note that professional cleaning will require a fee.
- There is the danger of accidents involving electrical shorts circuits or fire caused by factors such as the deterioration of insulation in electrical and electronic equipment over time. Check that there are no abnormalities such as odors from burning.
- Do not use a water jet (high pressure washing device) or hose to clean this product. It was not designed to be cleaned by a water jet. Water could get inside and cause electrocution or short circuits. The product could also be damaged in such a way that it is difficult to repair.

NOTE: The Service Manual referenced in the table is the separate "LINDBERGH RED EX Service Manual."

ITEMS	DESCRIPTION	PERIOD	REFERENCE
CABINET	Confirm that adjusters contact floor	Daily	2
HANDLE	Inspect volume	Monthly	10
	Inspect gear meshing	Every 3 months	10
	Apply grease	Every 3 months	10
MOTORCYCLE MECHANISM	Inspect volume	Monthly	11-1-1
	Inspect gear meshing	Every 3 months	11-1-1
	Apply grease	Every 3 months	11-1-3
	Inspect side guide plates	Daily	11-2
VIBRATION UNIT	Inspect screws for looseness	Monthly	11-3
COIN CHUTE TOWER	Coin switch inspection	Monthly	12-1
	Coin insertion test	Monthly	12-3
	Cleaning	Monthly	12-1
	Inspect door cushions	Monthly	See next page
DLP PROJECTOR	Screen cleaning	Weekly	13-1
	Check screen adjustment	Monthly or when moving	13
LINDBERGH RED EX	Memory test	Monthly	Service Manual, 4
	Settings check	Monthly	Service Manual, 4
	Cleaning	Every 3 months	17-2
BILLBOARD	Inspect lighting fixtures (fluorescent lamp)	As appropriate	14-1
SPEAKER UNIT	Inspect lighting fixtures (halogen lamp)	As appropriate	14-2
POWER CABLE	Inspection, Cleaning	1 year	6-10
CABINET INTERIOR	Cleaning	1 year	As above
CABINET SURFACES	Cleaning	As appropriate	See next page

Cleaning the Cabinet Surfaces

When the cabinet surfaces become dirty, remove stains with a soft cloth soaked in water or diluted (with water) chemical detergent and then wrung dry. To avoid damaging the finish, do not use such solvents as thinner, benzene, etc. (other than ethyl alcohol) or abrasives (bleaching agent and chemical dust-cloth).

Some general-purpose household, kitchen, and furniture cleaning products may contain strong solvents that degrade plastic parts, coatings, and print. Before using any cleaning product, read the product's cautionary notes carefully and test the product first on a small area that is not highly visible.

Replacing the Door Cushions

If the coin chute or cash box doors produce a loud vibrating noise, replace the door cushions.

1

Turn the power off.

2

Unlock the coin chute door with the master key and open it. Unlock the cash box door with the key and open it.

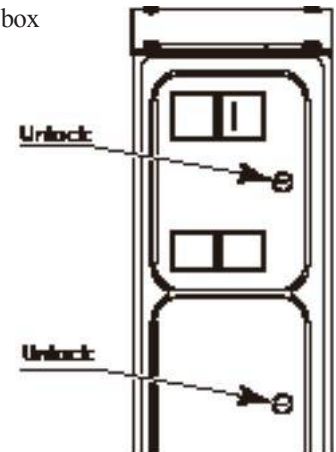

15 FIG. 01

3

Replace the door cushions with the ones supplied.

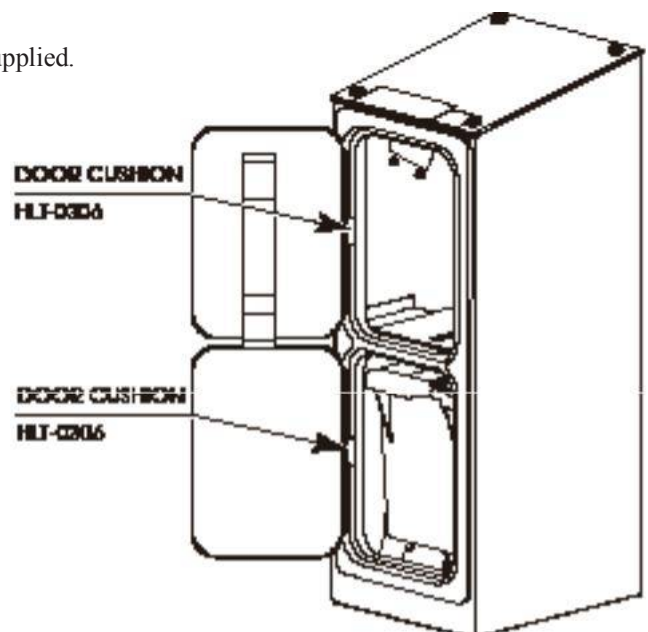

15 FIG. 02

16 TROUBLESHOOTING

16-1 TROUBLESHOOTING TABLE

⚠ WARNING

- The work described below should be carried out by the site maintenance personnel or other qualified professional. Work carried out by personnel without the necessary skill or technology can cause accident.
- If no improvements can be noted even after the following measures have been taken, disengage the power and contact the point of purchase or the office indicated in these instructions. If the power is left on while there is an abnormality, a fire, electric shock or other serious accident can occur.
- When working with the product, be sure to turn the power off. Working with the power on may cause an electric shock or short circuit.
- Be careful not to damage the wires. Damaged wires may cause an electric shock, short circuit or present a risk of fire.
- Once the reason that the breaker or circuit protector activated has been removed, restore the breaker or circuit protector to its original condition. If the product is used while the reason for activation has not yet been removed, heat and/or fire could be generated.

If a problem occurs, first inspect the connection of any wiring connectors.

NOTE: The Service Manual referenced in the table is the separate "LINDBERGH RED EX Service Manual."

16-1 TABLE 01

PROBLEMS	CAUSE	COUNTERMEASURES
With main switch ON, no activation.	Power is not supplied.	Securely insert the power plug into the plug socket.
	Power supply/voltage is not correct.	Make sure that power supply/voltage is correct.
	The circuit protector functioned due to the momentary overload.	After eliminating the cause of overload, reinstate the AC unit's circuit protector. <See below>
Billboard's fluorescent lamp does not light up.	Connector is not properly connected.	Firmly connect the connector between cabinet and billboard.
	Fluorescent lamp or glow lamp has expired.	Replace the fluorescent lamp and/or glow lamp. <See 14-1>
There is sound and the fluorescent lamp is on, but the monitor is completely black.	Video signal connector or monitor power connector is not properly connected.	Check to make sure the connector between the monitor and game board is properly connected.
	Characteristic of DLP projector.	Depending on the model, it may take approx. 2 minutes for the video signal to come through after turning the power on.
	Problem with monitor.	Contact the point of purchase for this product.

PROBLEM	CAUSE	COUNTERMEASURE
No sound.	Volume is not properly adjusted.	Adjust the sound on the switch unit. <See 9-1>
	Connector is not properly connected.	Check the connectors going to the game board, amps, speakers, and volume.
	Problem with board, amps, or speakers.	Check by performing the speaker test. <See Service Manual, 4>
The color on the DLP projector screen is incorrect.	Video signal connector is not properly connected.	Check to make sure the video signal connector is properly connected and fastened in place.
	Faulty screen adjustment.	Perform appropriate adjustments. <See chapter 13>
Monitor screen shakes or shrinks.	Power supply/voltage is not correct. Power is not sufficient.	Make sure that power supply/voltage is correct.
Switch or volume input does not work.	Connector is not properly connected.	Check the connection of the connector between the I/O board and the cabinet.
		Check the connection of the connector between the I/O board and the game board.
		Check the power to the I/O board.
Handle, accelerator, or brakes do not work as intended.	Faulty volume setting.	Configure the setting in Test Mode. <See 9-3-5>
	Faulty volume attachment or gear meshing.	Make adjustments and check them in Test Mode. <See chapter 10>
	Connector is not properly connected.	Check the connection of the handle, accelerator, and brake connectors.
	Volume is broken.	Replace the volume. <See chapter 10>
Motorcycle mechanism does not move as intended.	Faulty initialization operation.	Turn the power on again and make sure the initialization operation finishes properly.
	Faulty volume attachment or gear meshing.	Make adjustments and check them in Test Mode. <See 11-1-1>
	Volume is broken.	Replace the volume. <See 11-1-2>
	Wire is broken or disconnected.	Check wires around moving parts for poor contact. When replacing wires, fasten them down where they will not come in contact with moving parts.
Motorcycle mechanism does not move.	Faulty initialization operation.	Make sure the initialization operation finishes properly.
	Setting is not correct.	Check the LEAN setting on the GAME ASSIGNMENTS Screen. <See 9-3-4>
	Connector is not properly connected.	Check the connection of the connectors between the game board and the servo driver, and between the servo driver and the servomotor.
	Servomotor's thermal element was triggered.	Rise in internal temperature triggered element. Once it cools down, it will automatically recover.
	Servo driver's fuse blew due to momentary overload.	Contact the point of purchase for this product.

PROBLEM	CAUSE	COUNTERMEASURE
Network play does not work.	Network play settings are not correct.	Configure the settings correctly. <See 9-3-6 and 19-3>
	Network cable has come loose.	Connect the network cable properly. <See 19-2>
	Network cable cannot be properly connected.	Connect the network cable properly. <See 19-2>
	Network cable is broken.	Replace the network cable. Contact the point of purchase for this product.
Halogen lamp does not turn on.	Halogen lamp has expired.	Replace the halogen lamp. <See 14-2>
	Fuse is blown.	Replace the fuse. <See 16-2>
No vibration.	Setting is not correct.	Check the VIBRATION setting on the GAME ASSIGNMENTS Screen. <See 9-3-4>
	Connector is not properly connected.	Check the connection of the connector between the motor control board and the motor.
	Motor has expired.	Replace the vibration unit. <See 11-3>
Leader lamp, foot lamp, or tail lamp does not turn on.	Connector is not properly connected.	Check the connection of the connector.

CIRCUIT PROTECTOR

Functions due to the activation of bimetal. To restore the function, wait for approximately 1 minute or longer until the bimetal cools off. (Press the button.)

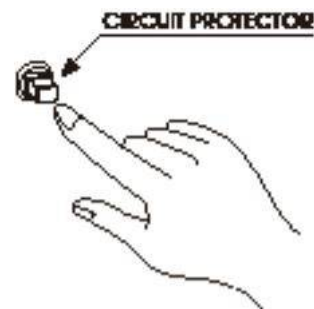

16-1 FIG. 01

17 GAME BOARD (LINDBERGH RED EX)

WARNING

- The work described below should be carried out by the site maintenance personnel or other qualified professional. Work carried out by personnel without the necessary skill or technology can cause accident.
- In order to prevent electric shock and short circuit hazards, be sure to turn power off before performing work.
- Be careful not to damage the wires. Damaged wires may cause electric shock or short circuit or present a fire risk.
- Do not use this product with connectors other than those that were connected and used with the LINDBERGH RED EX at the time of shipping. Do not carelessly connect wires to connectors that were not used at the time of shipping, as this may cause overheating, smoke or fire damage.
- When connecting the connectors, be sure to attach them correctly. There is only one correct way in which they must be connected. Attempting to connect them incorrectly may cause damage to the pins on the connectors, and cause electric shock, short circuit or fire.

CAUTION

In this product, setting changes are made during the Test Mode. The LINDBERGH RED EX need not be operated. Use the LINDBERGH RED EX, etc. as is with the same setting made at the time of shipment so as not to cause electric shock and malfunctioning.

IMPORTANT

Static electricity from your body may damage some electronics devices on the IC board. Before handling the IC board, touch a grounded metallic surface so that the static electricity can be discharged.

17-1 CLEANING THE LINDBERGH BOARD

STOP IMPORTANT

Be sure to clean game boards once in 3 months. Dust accumulating in game boards may not function properly.

Once every 3 months remove the LINDBERGH RED EX from the cabinet and use a vacuum cleaner to clean around the LINDBERGH RED EX's air vents and installation area.

1 Refer to 17-1, and remove the LINDBERGH RED EX from the cabinet.

2 Clean around the air vent of LINDBERGH boards with a vacuum cleaner.

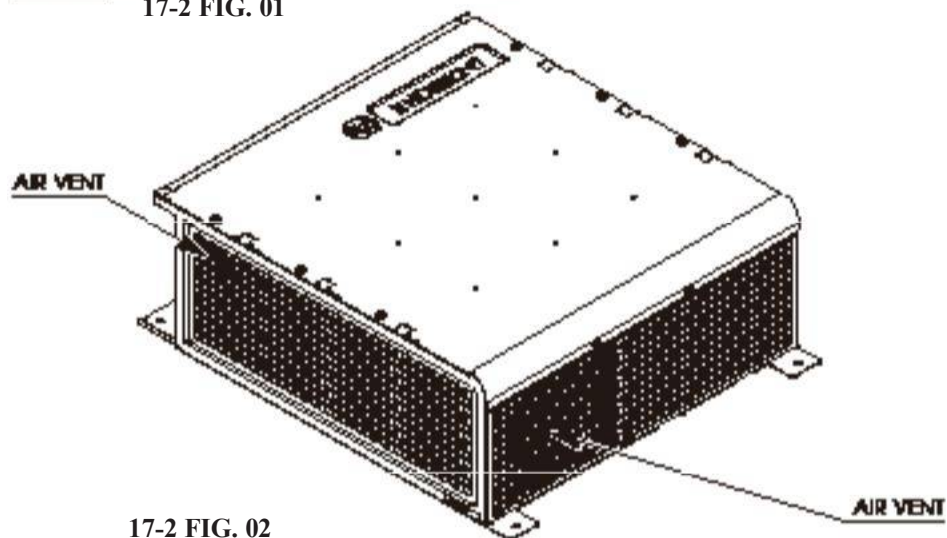
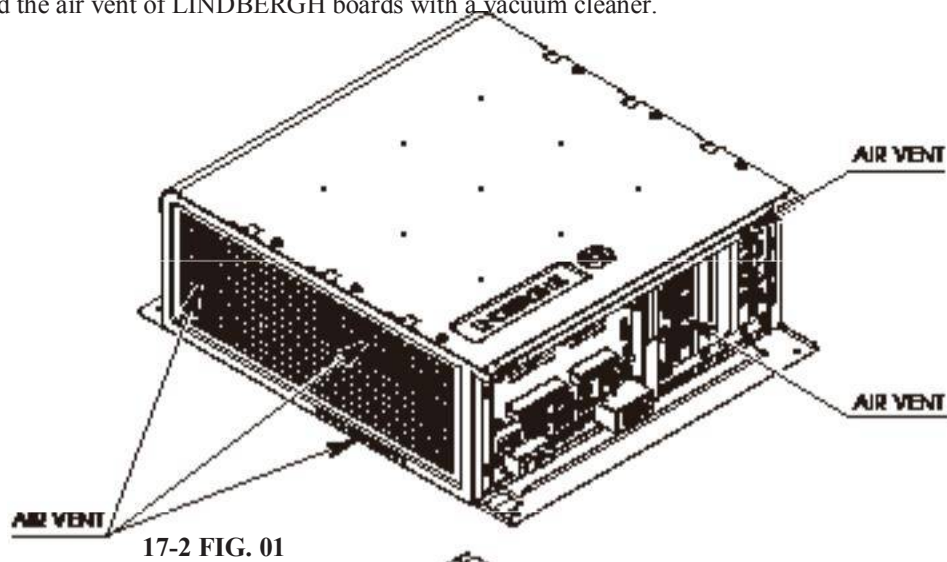

3 Clean around installment parts of LINDBERGH RED EX in the cabinet with a vacuum cleaner. Be sure not to damage wirings and boards. Electronic devices on boards may damage by static electricity, and be sure not to vacuum electronic devices by a vacuum cleaner.

4 Reinstall the LINDBERGH RED EX you removed by the reverse method.

17-2 COMPOSITION OF GAME BOARD

IMPORTANT

- With the key chip inserted into it, this LINDBERGH RED EX serves as a special-purpose LINDBERGH RED EX for the product.
- Use with the dip switches (DIP SW) on the board at the prescribed settings. If settings do not match the product, an error message will be displayed. In some cases, the game cannot be started.

ASSY CASE LBJ L 1GB HLT EXP (845-0014D-02)

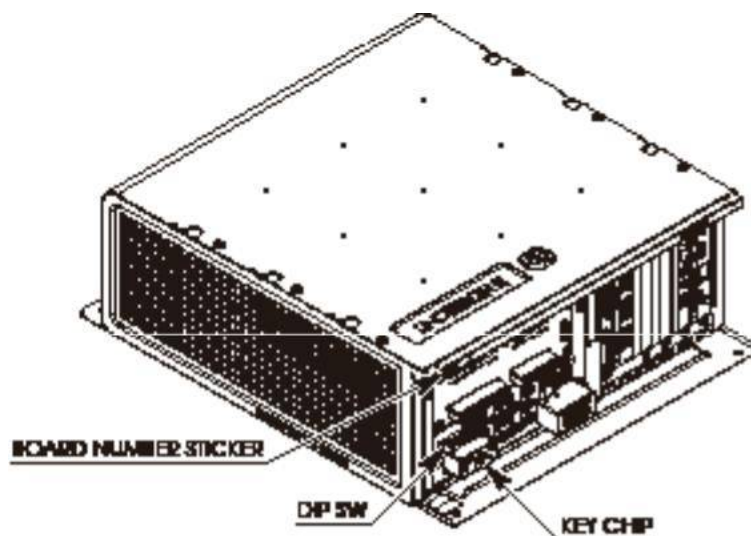

17-3 FIG. 01

DIP SW Settings

Use this product with the DIP SW settings shown in the figure below.



17-3 FIG. 02

18 NETWORK PLAY

With this product, up to 4 machines can be connected with network (LAN) cables for network play.

18-1 INSTALLATION PRECAUTIONS

WARNING

- The work described below should be carried out by the site maintenance personnel or other qualified professional. Work carried out by personnel without the necessary skill or technology can cause accident.
- Before starting to work, ensure that the Power SW is OFF. Failure to observe this can cause electric shock or short circuit.
- Use care so as not to damage wirings. Damaged wiring can cause electric shock or short circuit.
- Do not touch undesignated places. Touching places not designated can cause electric shock or short circuit.
- Multiple game machines will be connected for network play, so be sure to provide sufficient power according to the number of machines. Make sure that each game machine is supplied with the current listed in this manual. If the machines are used with different electrical specifications, it could result in fires or electrocution.
- The distance between the game machines is limited by the length of the communication cables used, but place them as far apart as possible. If the machines are too close together, it could result in a serious injury such as the player hitting his or her head on the other machine if he or she falls off. The distance between the machines shown in this manual is for when the optional equipment has been installed.
- Do not perform work on inclined surfaces, surfaces with different levels, or grooves. Doing so could result in a serious injury such as the worker tripping and falling. It will also prevent the work from being performed properly.

CAUTION

- To perform work safely, be sure to secure the space corresponding to number of machines to be linked. Failure to observe this can cause accident.
- If the network cables are laid out in the aisles, select a cable cover that is shaped so as not trip the customers. Otherwise customers may trip and fall.
- To prevent accidents and acts of vandalism, cover the network cables with the strongest cover possible.

Supply the appropriate power to each of the 4 game machines. Each one should be supplied with around 15 A of power.

Installing the Game Machine

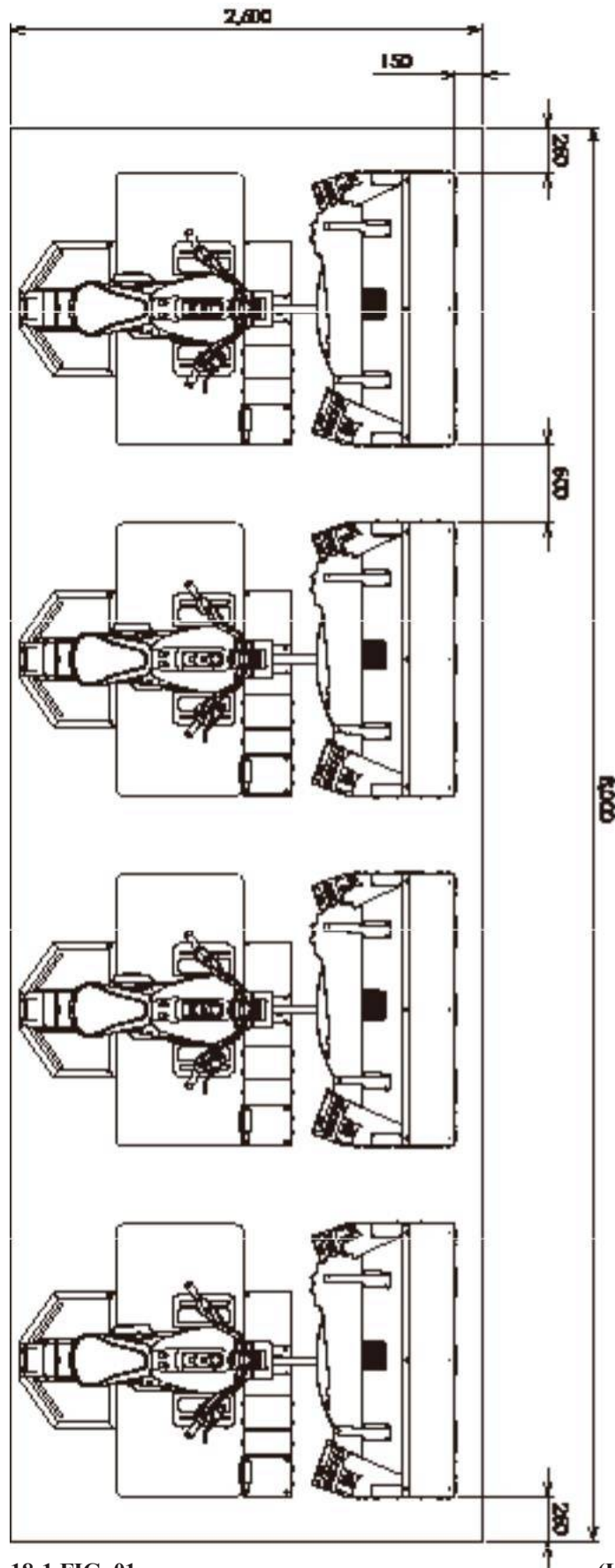

18-1 FIG. 01

(Unit: mm)

19 DESIGN RELATED PARTS

555-30-100
MARQUEE HLT DX

555-30-101
TOP FRAME DECAL HLT

555-30-200
SIDE DECAL LEFT HLT DX

555-30-103
BUTTOM FRAME
DECAL HLT DX

HLT-3008/3009
TANK L/R

HLT-3533-P1
STICKER NUMBER
PLATE

HLT-3507
TAIL LAMP COVER



KING OF THE ROAD



555-30-201
SIDE DECAL
RIGHT HLT DX

555-30-102
FRONT CABINET
DECAL HLT DX

555-30-104
PLAY INSTR
HLT DX

HLT-3352
STICKER CENTER SW

HLT-0001
MAT

HLT-3509/3510
STICKER TYRE
SIDE L/R

HLT-3018-01/3019-01
STICKER REAR BASE
L ENG/R ENG



20 PARTS LIST

1 BILLBOARD UNIT

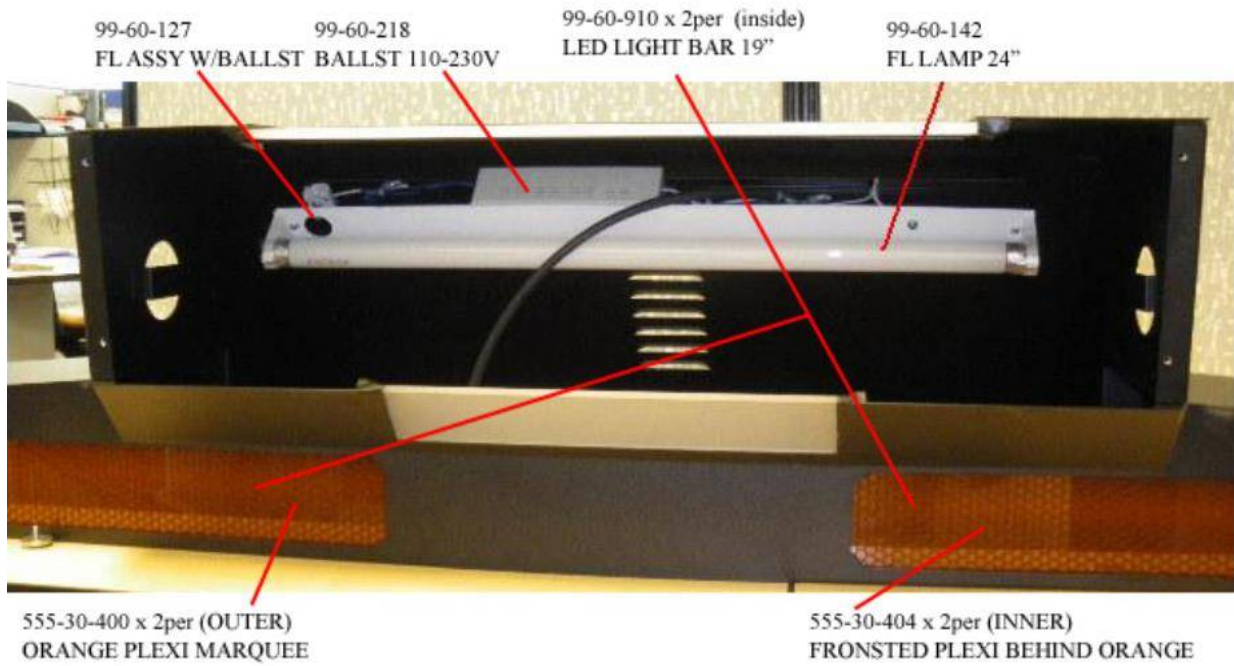

2 DLP UNIT

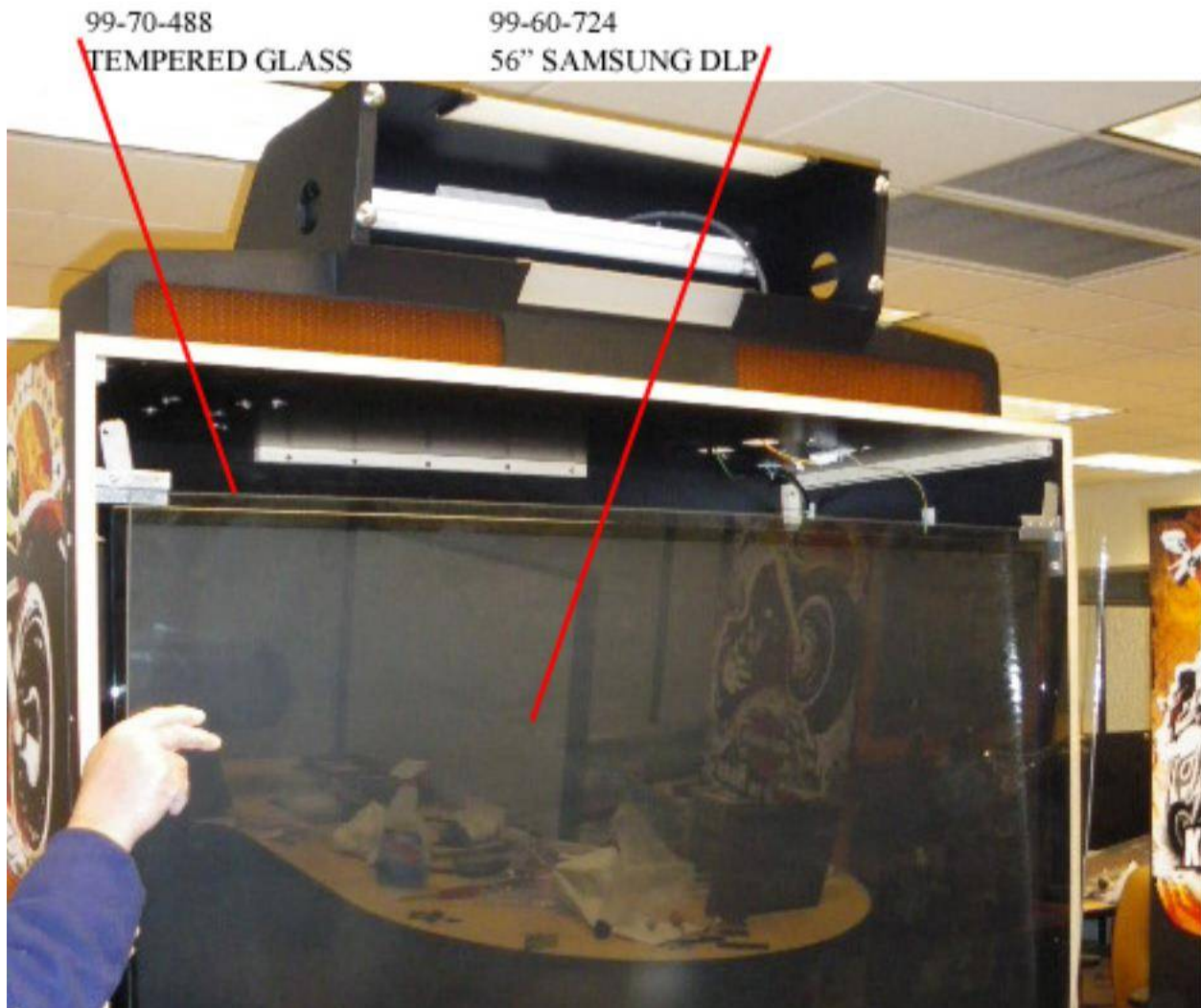

3) COIN TOWER UNIT

HLT-0400
ASSY TUBE BIKE

838-14548-01
SW& VOL BD



4) AC UNIT

99-00-014 (INSIDE CABI)
LINE FILTER 874-06/003

99-00-001E
POWER SW VDE

99-00-015
FUSE HOLDER W/CAP
99-60-776(INSIDE CABI)
FUSE 8AMP

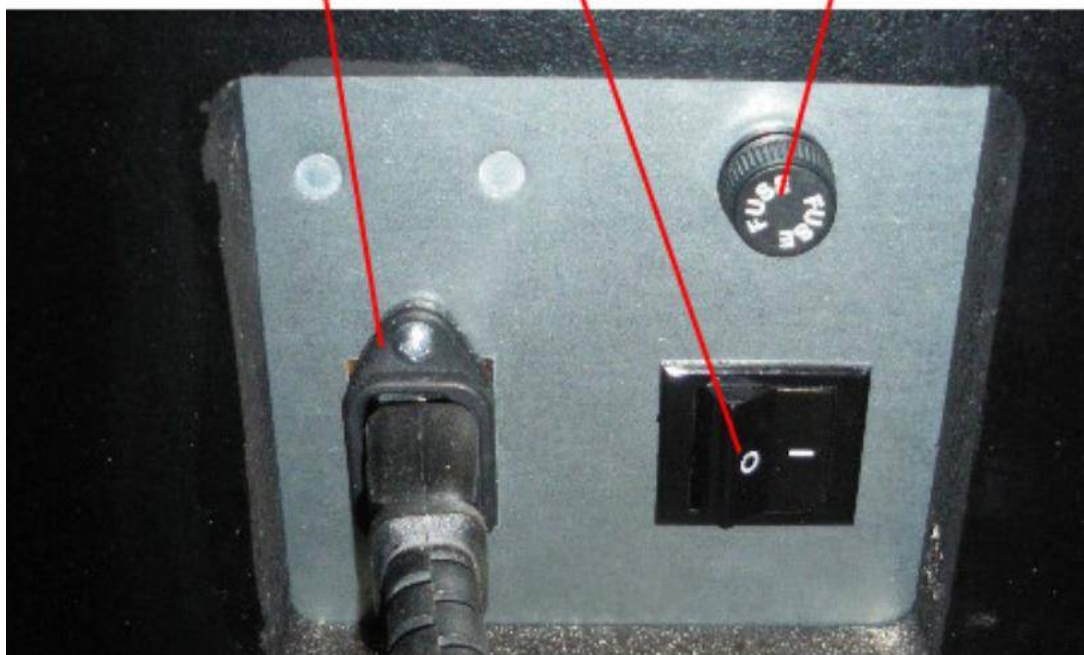

5 CPU UNIT

845-0001D-11(-12 for EU)
ASSY LINDBERGH

610-0719-01-91
DVD DRIVE UNIT USB

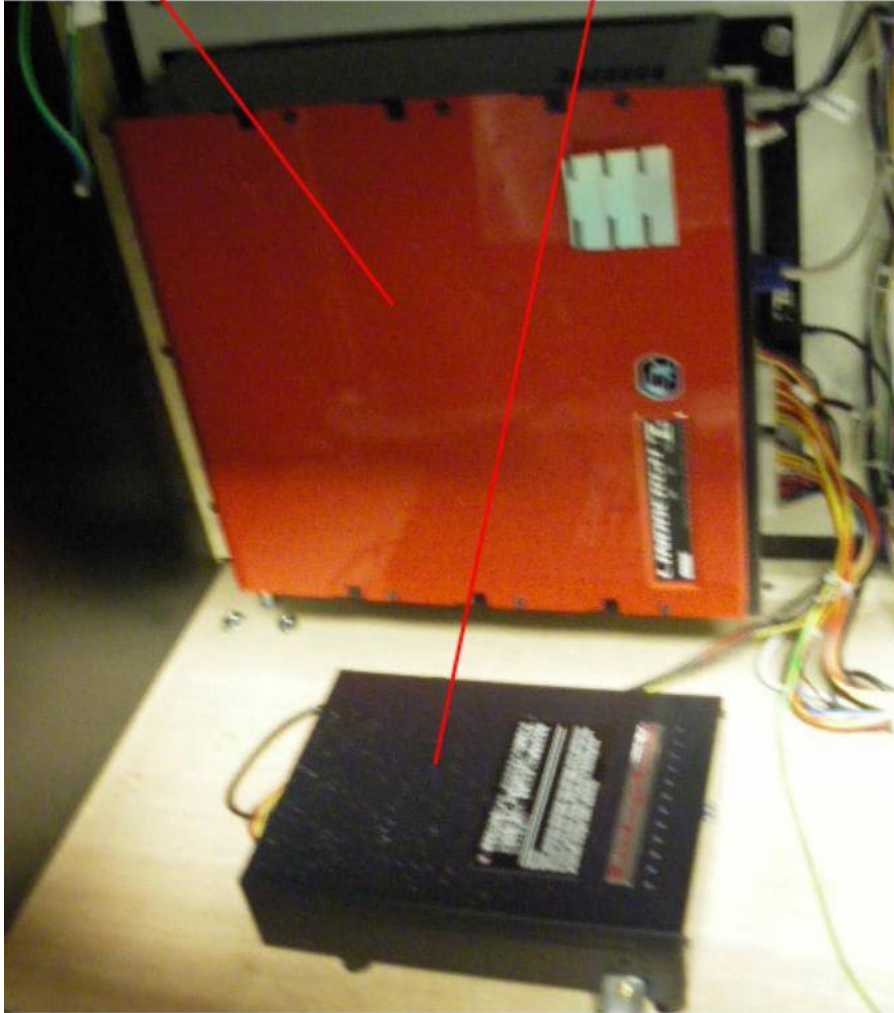

6 POWER SUPPLY UNIT

99-60-221
TRANSFORMER
120V-100V 8A

400-5457-92
SW REGU ATX/JVS



7)ELEC UNIT

39-1256R	839-1377	839-1148R	839-14572	400-5421-07512
IS232 TO 422 BD	DC MOTOR	4A DC SSR	I/O CTRL BD 3	SW REGU LCA
	PWM BD	BD NH4P	FOR JVS COM	75S-12

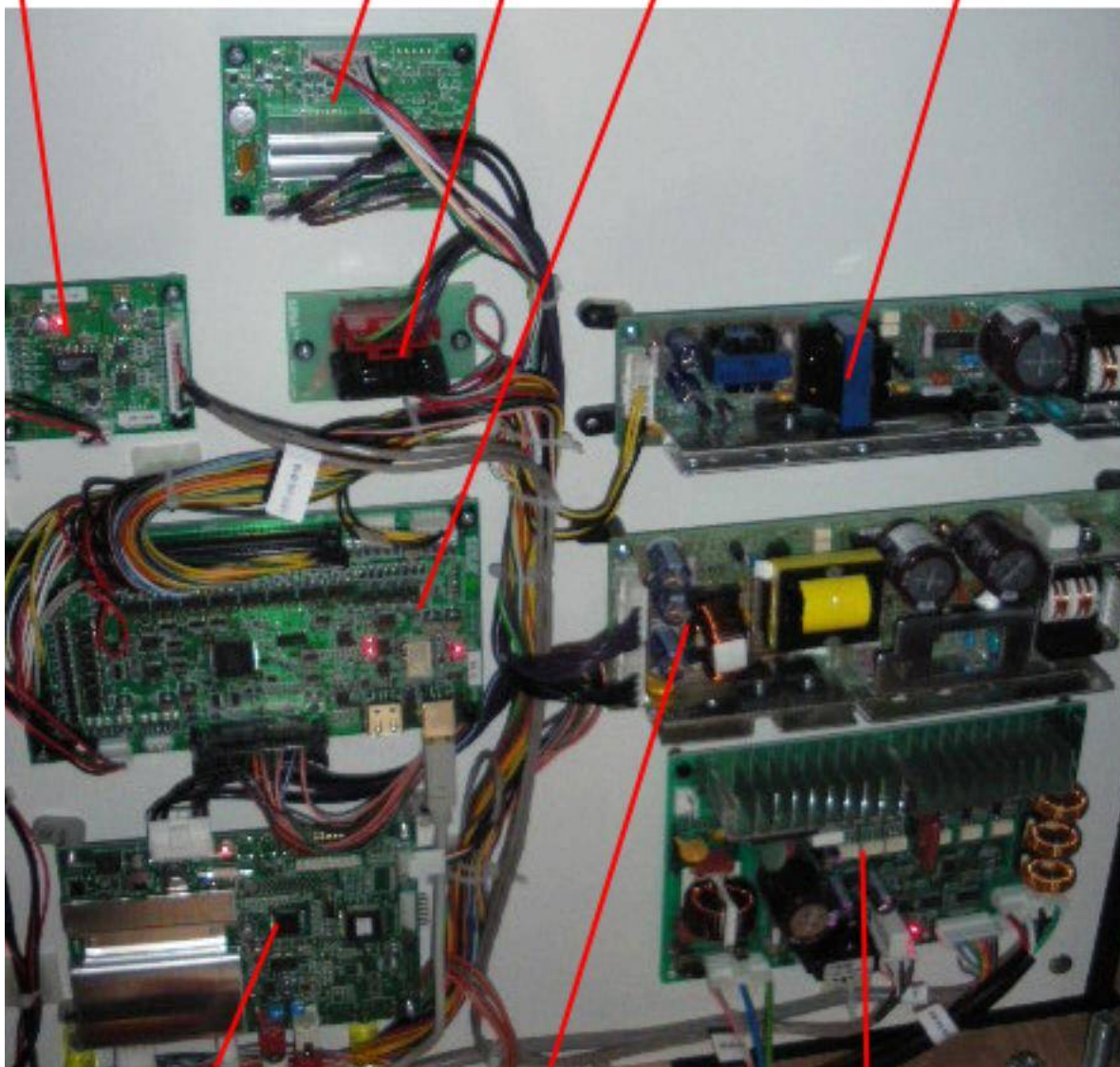

38-14515-A05
OUND AMP
ANALOG IN

400-5421-15024
SW REGU LCA
150S-24

838-14592-91
SERVO MOTOR
DRIVER BD SER

8 ASSY REAR CABINET (HLT-3000)

(D-1/3)

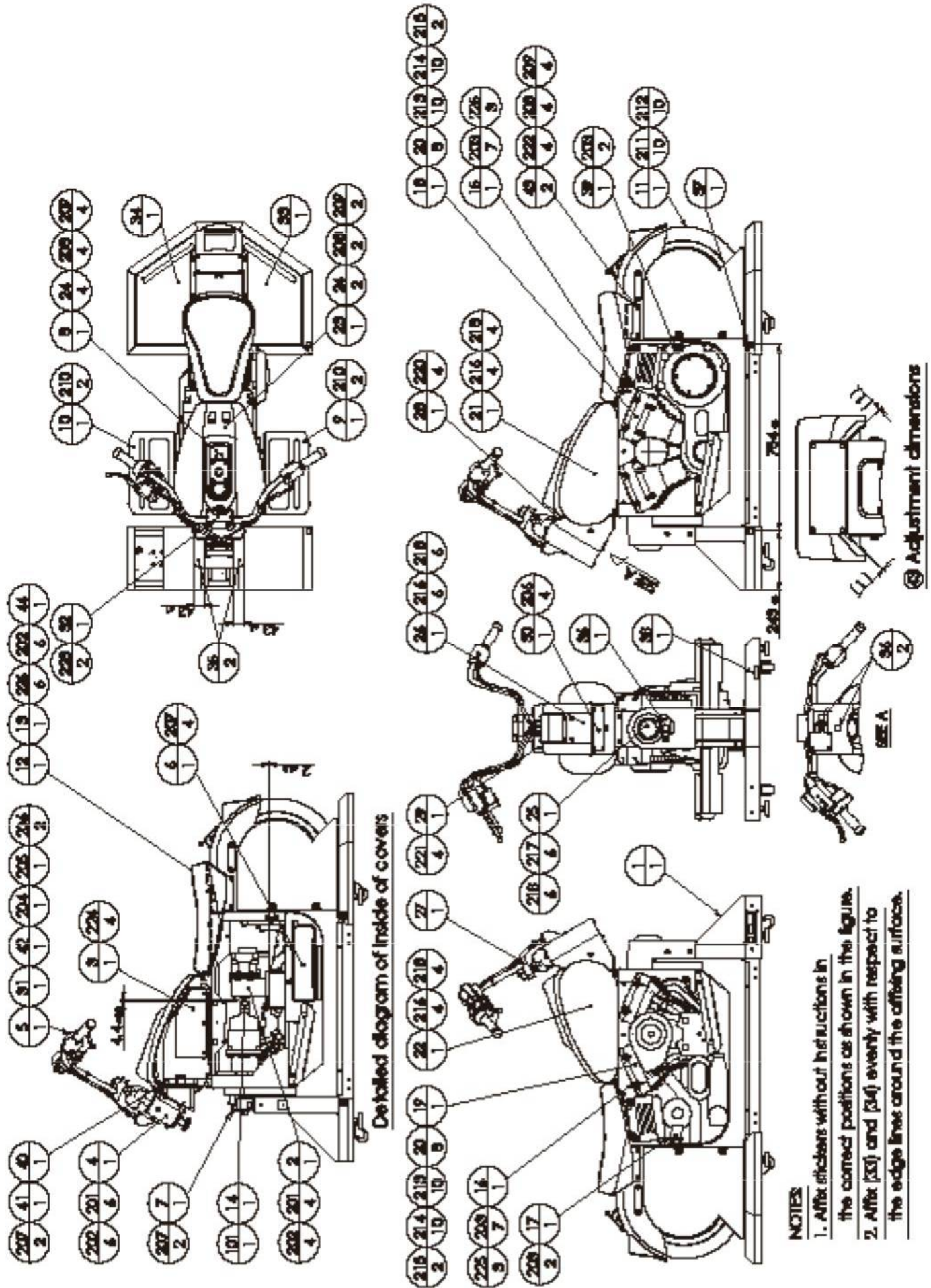

8 ASSY REAR CABINET (HLT-3000)

(D-2/3)

ITEM NO.	PART NO.	DESCRIPTION	NOTE
1	HLT-3100	ASSY RIDE BASE	
2	HLT-3200	MOTOR UNIT	
3	HLT-3250	VIBRATION UNIT	
4	HLT-2000	ASSY CENTERING MECHA	
5	HLT-2100	ASSY HANDLE DLX	
6	HLT-3300	ASSY WOOFER	
7	HLT-3320	ASSY ROLL VOLUME	
8	HLT-3350	ASSY SW PLATE	
9	HLT-3400	ASSY STEP L	
10	HLT-3400	ASSY STEP R	
11	HLT-3400	ASSY REAR FENDER	
12	HLT-3001	BIKE SEAT	
13	HLT-3002	SEAT BRKT	
14	123-050520-2R	KEY 5x5x20 2R	
15	HLT-3003	ENGINE COVER LID L	
16	HLT-3004	ENGINE COVER LID R	
17	HLT-3005	ENGINE COVER BRKT R	
18	HLT-3006X	ENGINE COVER L	
19	HLT-3007X	ENGINE COVER R	
20	250-5715-05	SPCL WASHER M5 HLT	
21	HLT-3008	TANK L	
22	HLT-3009	TANK R	
23	HLT-3010	TANK CENTER	
23	250-5716-04	SPCL WASHER M4 HLT	
24	HLT-3011	FRONT SHAFT COVER	
25	HLT-3012X	HANDLE FRONT COVER	
26	HLT-3013	HANDLE MAIN SHAFT COLLAR	
27	HLT-3014	HANDLE FRONT COVER LID A	
28	HLT-3015	HANDLE FRONT COVER TOP	
29	HLT-3016	HANDLE FRONT COVER LID B	
30	123-050540-R	KEY 5x5x40 R	
31	HLT-3017X	HANDLE MOUNT PLATE	
32	HLT-3018-01	STICKER REAR BASE L ENG	
33	HLT-3019-01	STICKER REAR BASE R ENG	
34	HLT-3020	STICKER FRONT FORK	
35	440-CS0245-EG	STICKER C GEAR S ENG	
36	421-11416	STICKER CAUTION FORK	
37	HLT-3021	ENGINE COVER BRKT L	
37	HLT-3022	ENGINE COVER BRKT L	
39	HLT-3023	HANDLE COVER SASH	
40	HLD-3034	HANDLE COVER SASH SPONGE	
41	HLT-3024X	SEAT SIDE GUIDE PLATE	
42	HLT-3027	HANDLE WSHR	
43		SEAT SPACER PLATE	
101	111-1164	COUPLING NES70W-N12CXN14C-TK	
102	280-5275-SR10	CORD CLAMP SR10	
103	601-0460	PLASTIC TIE BELT 100M/M	

8 ASSY REAR CABINET (HLT-3000)

(D-3/3)

ITEM NO.	PART NO.	DESCRIPTION	NOTE
201	030-000816-S	HEX BLT W/S M8x16	
202	060-F00800	FLT WSHR M8	
203	000-P00510-W	M SCR PH W/FS M5x10	
204	030-001020-S	HEX BLT W/S M10x20	
205	028-A00408-P	SET SCR HEX SKT CUP P M4x8	
206	000-P00408-WB	M SCR PH W/FS BLK M4x8	
207	000-P00408-W	M SCR PH W/FS M4x8	
208	FAS-290042	HEX SKT LH CAP SCR STN M4x12	
209	060-S00400	SPR WSHR M4	
210	000-T00408-0C	M SCR TH CRM M4x8	
211	FAS-290030	HEX SKT SCR BH BLK M6x16	
212	068-552018-0B	FLT WSHR BLK 6.5-20x1.6	
213	FAS-290037	HEX SKT LH CAP SCR STN M5x20	
214	060-S00500	SPR WSHR M5	
215	000-P00412-WB	FLT WSHR CRM 5.5-20x1.6	
216	000-T00408-0B	M SCR PH W/FS BLK M4x12	
217	068-441616-0B	M SCR TH BLK M4x8	
218	008-T00408-0B	FLT WSHR BLK 4.4-16x1.6	
220	008-T00408-0C	TMP PRF SCR TH BLK M4x8	
221	068-441616-0C	TMP PRF SCR TH CRM M4x8	
222	FAS-290071	FLT WSHR CRM 4.4-16x1.6	
223	030-000816-W	HEX SKT FLH CAP SCR STN M4x10	
224	000-T00510-0B	M SCR TH BLK M5x10	
225	030-000825-S	HEX BLT W/FS M8x25	
226			

9 ASSY RIDE BASE (HLT-3100)

(D-1/2)

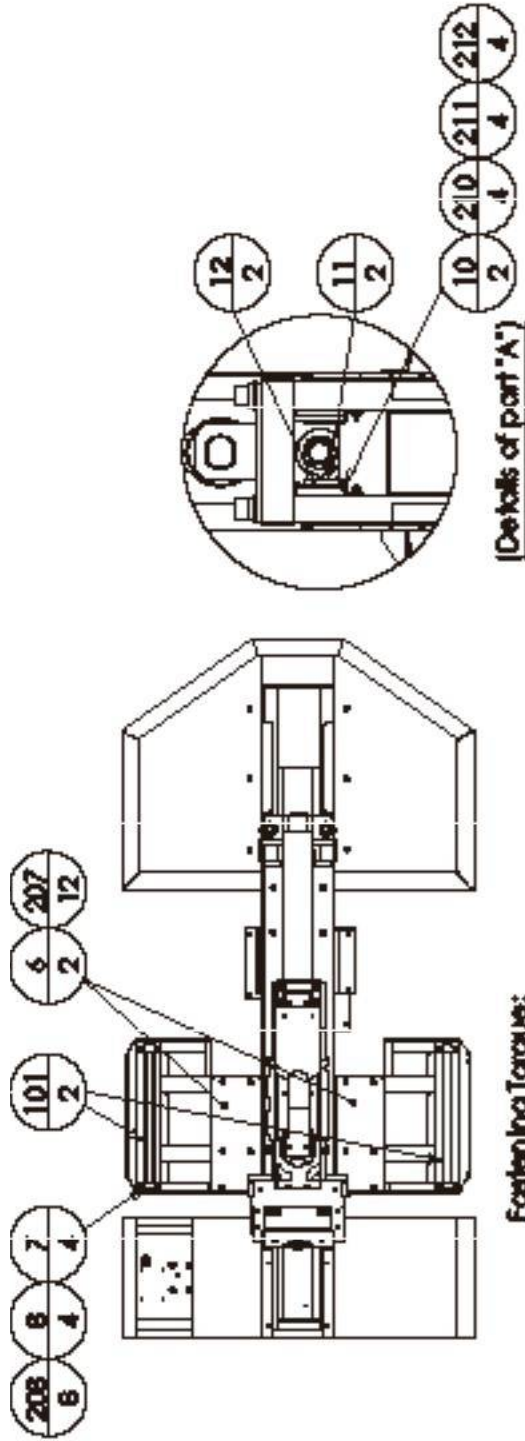

Fastening Torque:

20) (M14):12N · m (1240 kgf · cm)

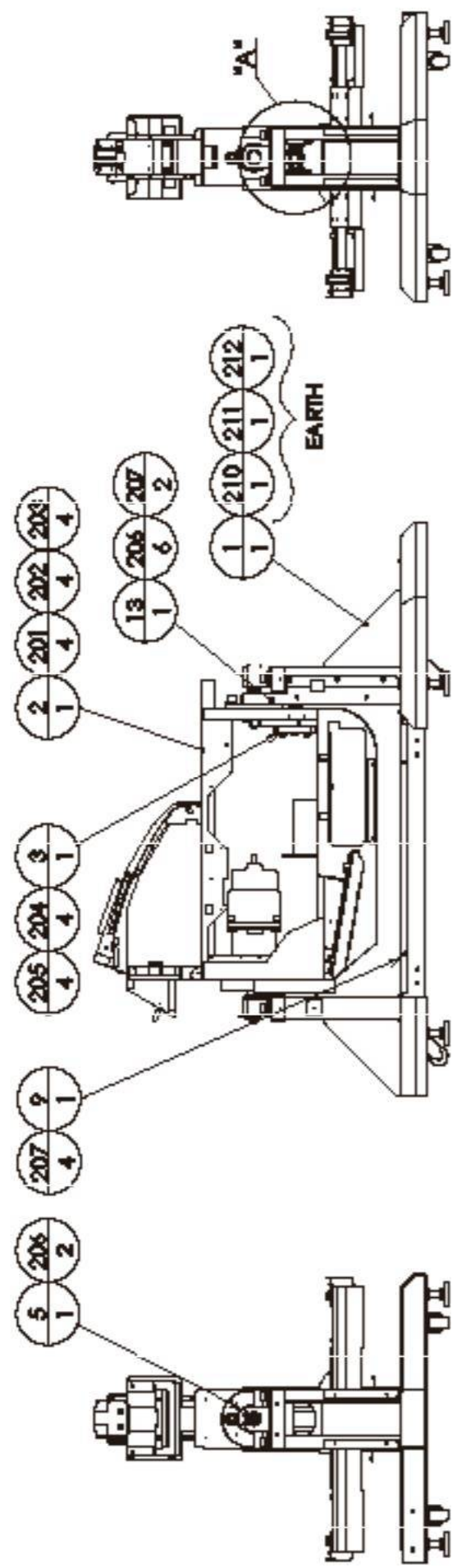

9 ASSY RIDE BASE (HLT-3100)

(D-2/2)

ITEM NO.	PART NO.	DESCRIPTION	NOTE
1	HLT-3101	ASSY SUBCABI REAR	
2	HLT-3150	ASSY RIDE MECHA	
3	HLT-3103Y	STOPPER SHAFT	
5	HLT-3105	GEAR 110 HLT	
6	HLT-3106	STEP LID	
7	HLT-3107	STEP LED HOLDER	
8	HLT-3108	STEP SPONGE	
9	HLT-3109	BASE LID	
10	HLT-3110	RUBBER BRKT	
11	HLT-3111X	RIDE STOPPER RUBBER	
12	HLT-3112	RIDE STOPPER URETHANE	
13	HLT-3113	FENDER HOLDER	
101	390-6967	LED PIPE 300MM BLUE	
102	280-6676	CORD CLAMP TL-25A TKK	
103	280-5277	CORD CLAMP 18	
104	280-5275-SR10	CORD CLAMP SR10	
201	FAS-200005	HEX SKT H CAP SCR B 0Z M1 4x40	
202	060-S01400	SPR WSHR M14	
203	060-F01400	FLT WSHR M14	
204	030-000816-S	HEX BLT W/S M8x16	
205	060-F00800	FLT WSHR M8	
206	000-P00408-W	M SCR PH W/FS M4x8	
207	000-T00408-OB	M SCR TH BLK M4x8	
208	000-P00308-W	M SCR PH W/FS M3x8	
210	050-H00400	HEX NUT M4	
211	060-S00400	SPR WSHR M4	
212	060-F00400	FLT WSHR M4	
301	HLT-60028	WH REAR CABINET01	

⑩ ASSY SUBCABI REAR (HLT-3101)

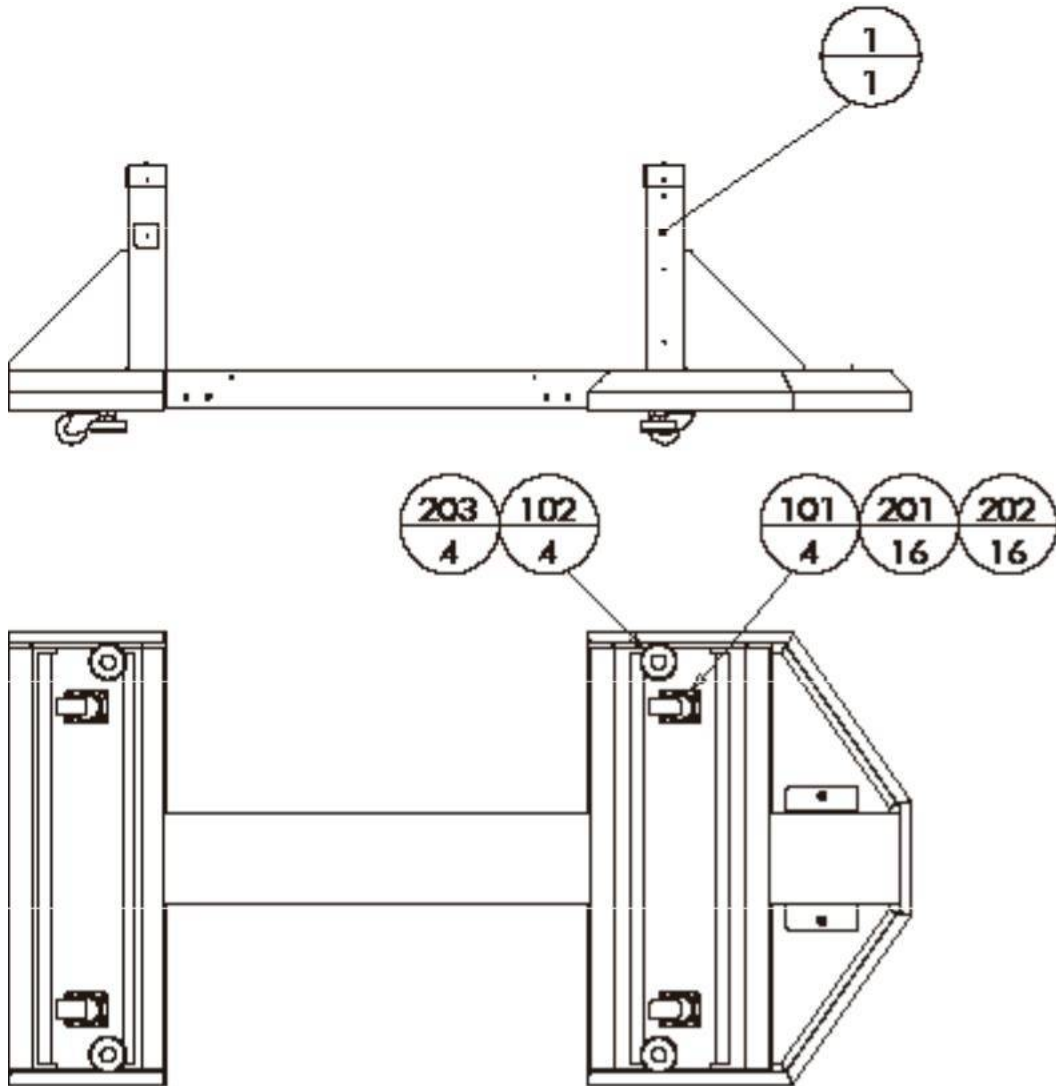

ITEM NO.	PART NO.	DESCRIPTION	NOTE
1	HLT-3102	REAR BASE	
101	601-6056-01	CASTER 50 PH	
102	601-5882	LEG ADJUSTER (TAKIGEN C-280-2)	
201	030-000616-S	HEX BLT W/S M6x16	
202	060-F00600	FLT WSHR M6	
203	050-H01600-3	HEX NUT TYPE3 M16	

11 ASSY RIDE MECHA (HLT-3150)

(D-1/2)

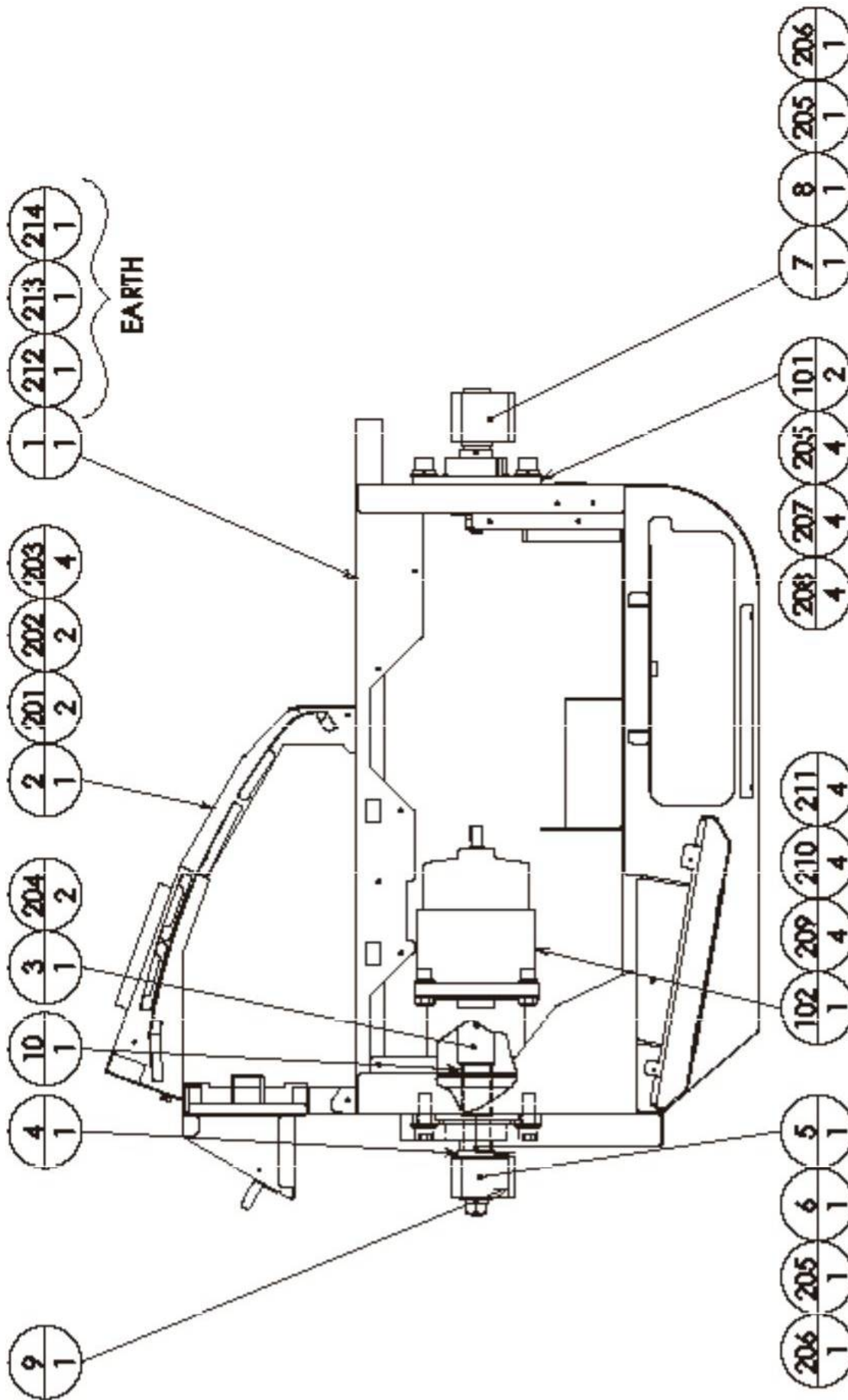

Fastening Torque:

207 (M14): 122 N · m (1240 Kgf · cm)

11 ASSY RIDE MECHA (HLT-3150)**(D-2/2)**

ITEM NO.	PART NO.	DESCRIPTION	NOTE
1	HLT-3151X	RIDE MECHA	
2	HLT-3152X	TANK CENTER FRAME	
3	HLT-3153	FRONT SHAFT	
4	HLT-3154	FRONT SHAFT SPACER	
5	HLT-3155	PILLOW BLOCK FRONT	
6	TTR-3205	FLT 14.5-36x3.2	
7	HLT-3156	PILLOW BLOCK REAR	
8	HLT-3157	FLT WSHR 14.5-55x3.2	
9	HLT-3114	SHAFT MASK	
10	HLT-3158	FRONT SHAFT SPACER LONG	
101	100-5552	BEARING 30 NTN UCFC206 W/HOLE	
102	350-5934	REDUCER CNV-5097 DR-175 200W	
103	280-6676	CORD CLAMP TL-25A TTK	
104	280-5277	CORD CLAMP 18	
105	280-5275-SR10	CORD CLAMP SR10	
106	310-5027-2203	INSL SLIT TUBE ID 22	
107	310-5027-1903	INSL SLIT TUBE ID 19	
108	601-5526-120	BUSH 1.6T	
110	601-0460	PLASTIC TIE BELT 100 M/M	
201	030-000612-S	HEX BLT W/S M6x12	
202	060-F00600	FLT WSHR M6	
203	000-P00510-W	M SCR PH W/FS M5x10	
204	028-A00608-P	SET SCR HEX SKT CUP P M6x8	
205	060-S01400	SPR WSHR M14	
206	050-H01400	HEX NUT M14	
207	FAS-200005	HEX SKT H CAP SCR B OZ M14x40	
208	060-F01400	FLT WSHR M14	
209	020-001030-OZ	HEX SKT CAP SCR BLK OZ M10x30	
210	060-S01000	SPR WSHR M10	
211	060-F01000	FLT WSHR M10	
212	000-P00408	M SCR PH M4x8	
213	060-S00400	SPR WSHR M4	
214	060-F00400	FLT WSHR M4	
215	060-F00400	MSCR FH M3x12	
301	000-F00312		
301	HLT-60029X	WH RIDE MECHA01	
302	HLT-60030	WH RIDE MECHA02	
303	HLT-60031	WH RIDE MECHA03	
304	HLT-60032	WH RIDE MECHA04	
305	HLT-60047	WH E RIDE MECHA	

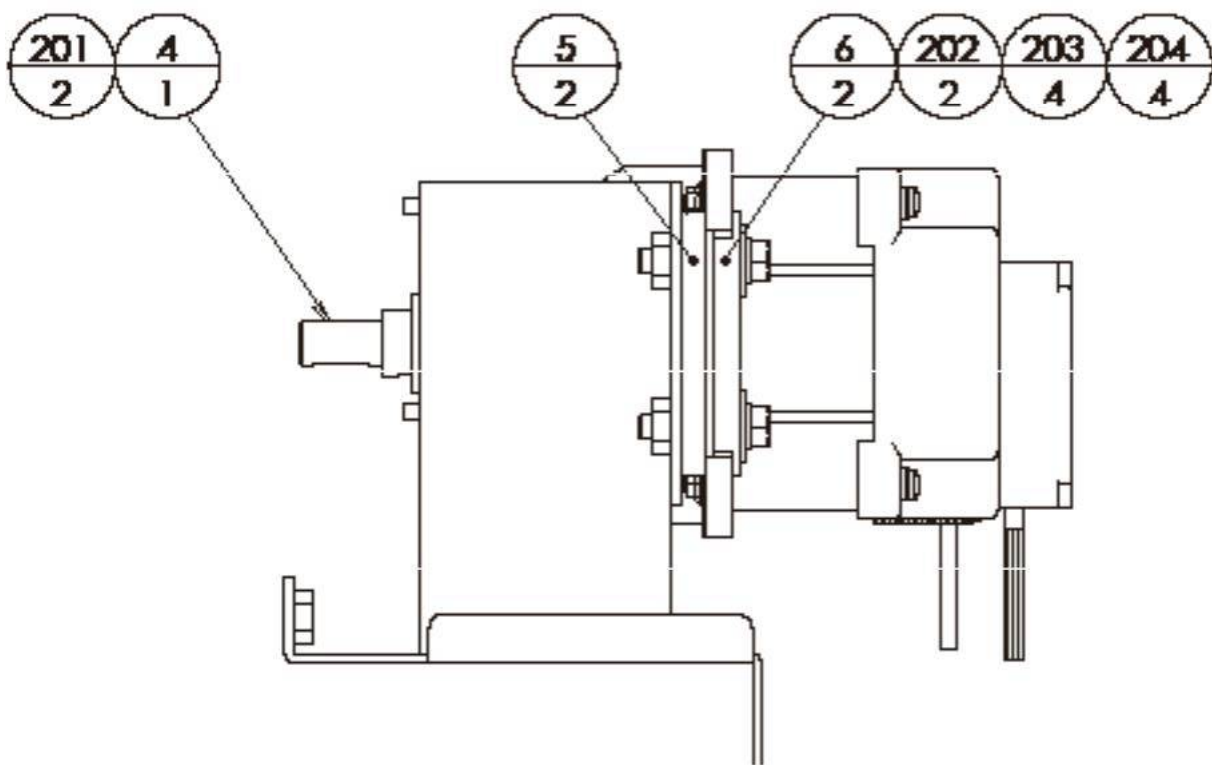
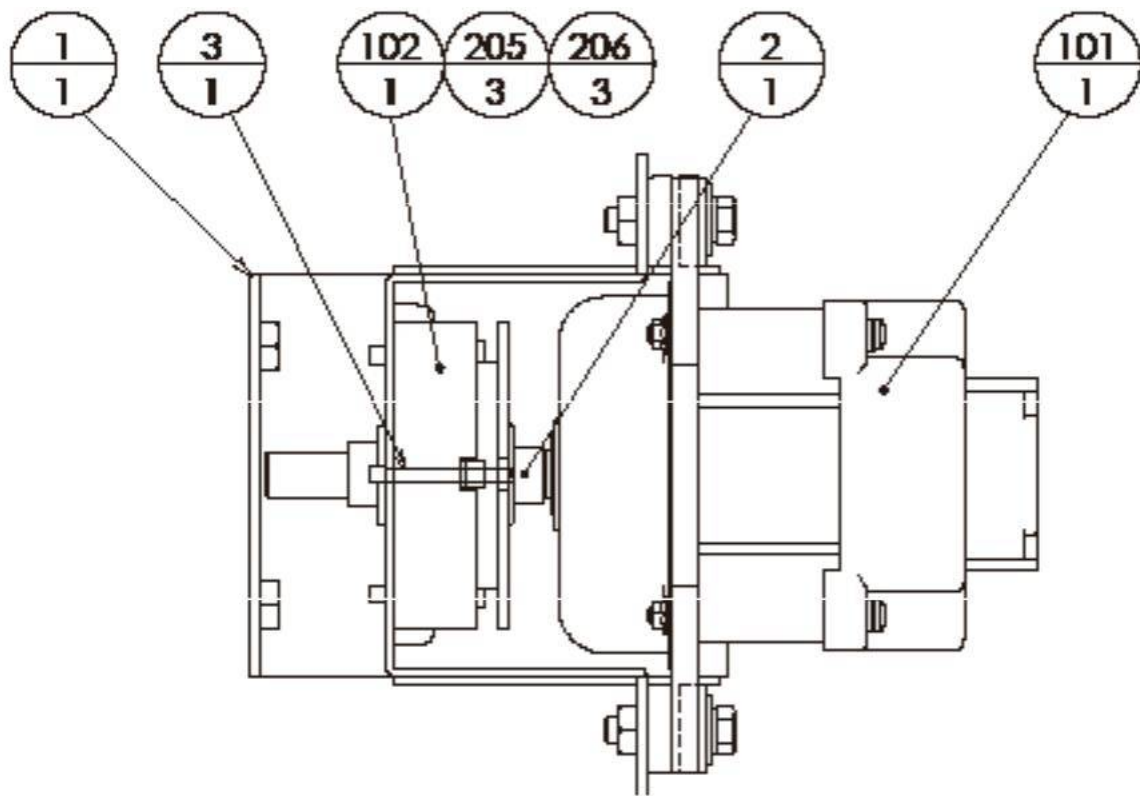

Fastening Torque:

203 (M8): 12.5 N · m {127.5 kgf · cm}

204 (M5): 3.1 N · m {31.6 kgf · cm}

12 MOTOR UNIT (HLT-3200)**(D-2/2)**

ITEM NO.	PART NO.	DESCRIPTION	NOTE
1	HLT-3201X	MOTOR BRKT	
2	ORA-2507	MOTOR SHAFT COLLAR	
3	SPG-2453	KEY 4x4x40	
4	HLT-3202	MOTOR JOINT BUSH	
5	253-5592	MOTOR INSULATOR A	
6	253-5593	MOTOR INSULATOR B	
101	350-5805-01	SERVO MOTOR W/FG Y21C-5010S	
102	601-11311	BRAKE BXH-08-10 24V	
103	211-5409	AMP S. S.PRESSOR CONN 172006-1	
104	211-5410	CONTACT 170284-1	
105	481-5511	DIODE 1S1887A(TOSHIBA)	
	481-5568	DIODE 1N4004RLG AXIAL ONSEMI	
106	601-0460	PLASTIC TIE BELT 100 M/M	
107	209-0023-91	CONN CLOSED END	
108	280-5275-SR10	CORD CLAMP SR10	
201	028-A00408-P	SET SCR HEX SKT CUP P M4x8	
202	012-P00412	TAP SCR #2 PH 4x12	
203	030-000835-S	HEX BLT W/S M8x35	
204	068-852216	FLT WSHR 8.5-22 x1.6	
205	020-000530-OZ	HEX SKT H CAP SCR BLK OZ M5x30	
206	060-S00500	SPR WSHR M5	
301	HLT-60039	WH MOTOR UNIT	

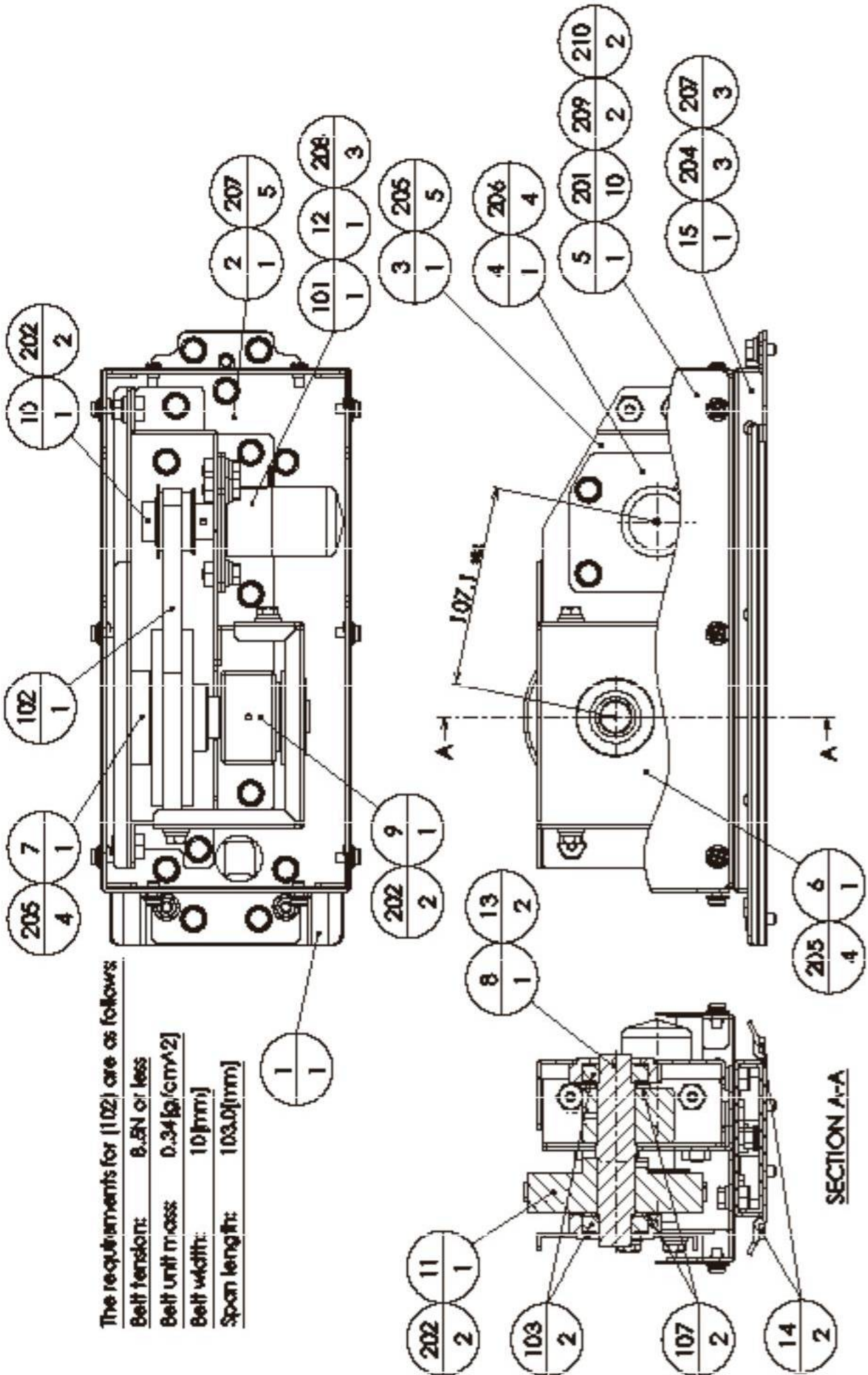

The requirements for [102] are as follows:

Belt tension:	8.5N or less
Belt unit mass:	0.34 [g/cm ²]
Belt width:	10 [mm]
Span length:	103.0 [mm]

13 VIBRATION UNIT (HLT-3250)**(D-2/2)**

ITEM NO.	PART NO.	DESCRIPTION	NOTE
1	HLT-3251	VIB FIELD	
2	HLT-3252X	VIB BASE	
3	HLT-3253X	VIB CENTER BRKT	
4	HLT-3254X	VIB MOTOR BRKT	
5	HLT-3255X	VIB COVER	
6	HLT-3256X	VIB BEARING HOLD CASE	
7	HLT-3257	VIB BEARING HOLD LID	
8	HLT-3258	VIB BEARING SHAFT	
9	HLT-3259	VIB BALLAST	
10	SPG-2504	PULLEY 20 S5M	
11	SPG-2505	PULLEY 60 S5M	
12	123-040414-2R	KEY 4x4x14 2R	
13	123-050515-2R	KEY 5x5x15 2R	
14	HLT-3260	VIB SPONGE	
15	HLT-3261X	VIB FIELD BED	
101	350-5937	MOTOR DMN37KB WITH BUSH	
102	350-5902	TIMING BELT S5M425	
103	100-5112	BEARING 17 (NSK 6003ZZ)	
105	209-0023-91	CONN CLOSED END	
106	601-0460	PLASTIC TIE BELT 100 M/M	
107	100-5445-21	OILES BEARING 80W-21	
108	270-5117	FERRITE CORE TDK ZCAT3035-1330	
109	280-5275-SR10	CORD CLAMP SR10	
110	280-6676	CORD CLAMP TL-25A TTK	
111	280-5277	CORD CLAMP 18	
201	000-P00510-W	M SCR PH W/FS M5x10	
202	028-A00408-P	SET SCR HEX SKT CUP P M4x8	
204	050-U00600	U NUT M6	
205	FAS-300053	HEX BLT W/FS M6x12	
207	060-F00600	FLT WSHR M6	
208	000-P00306-W	M SCR PH W/FS M3x6	
209	000-F00310	M SCR FH M3x10	
210	050-U00300	U NUT M3	
301	HLT-60040	WH VIBRATION UNIT	
302	HLT-60054	WH VIBRATION UNIT EXT	

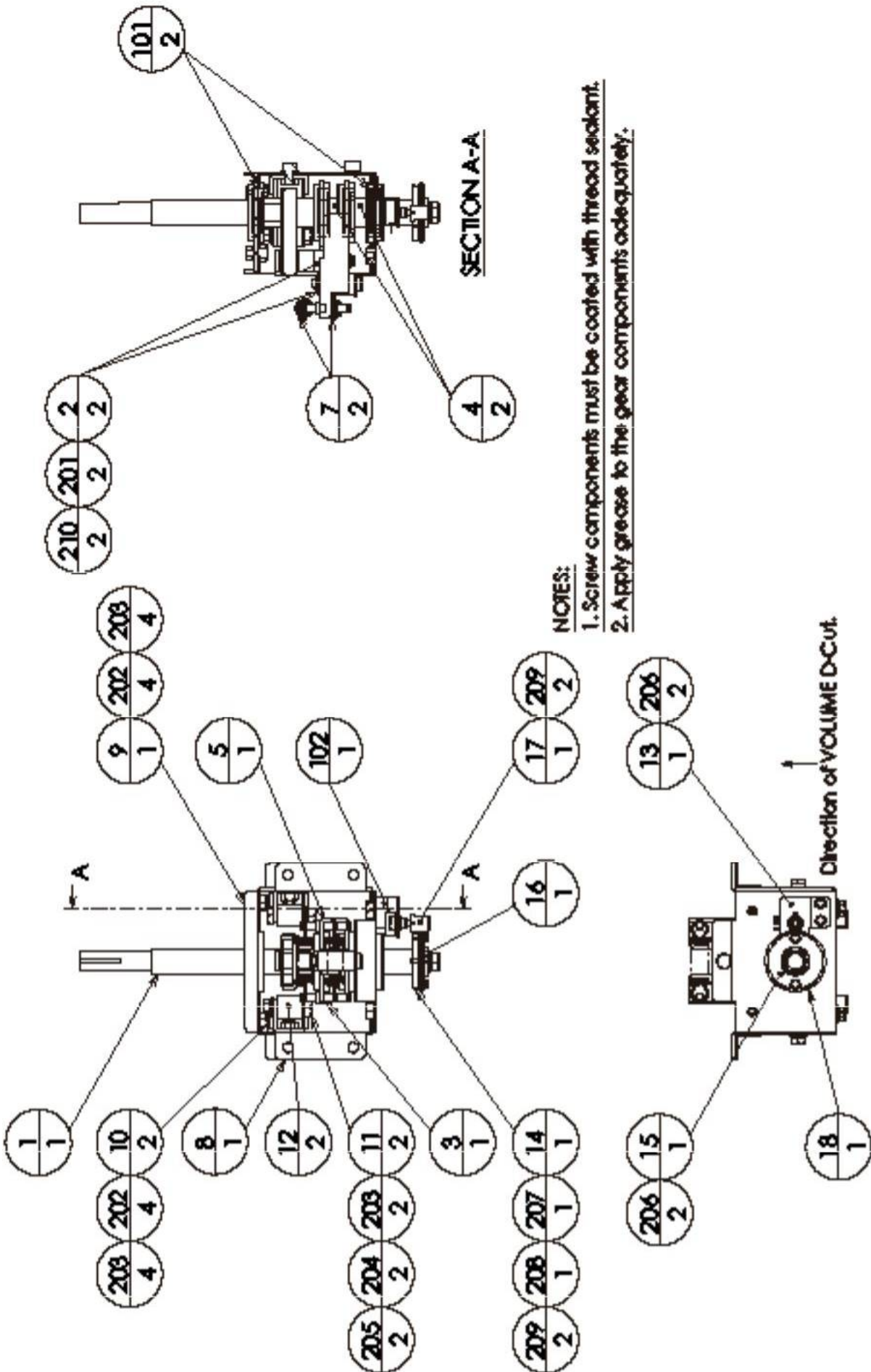

14 ASSY CENTERING MECHA (HLT-2000)

(D-2/2)

ITEM NO.	PART NO.	DESCRIPTION	NOTE
1	HLT-2001X	HANDLE MAIN SHAFT	
2	HLT-2002	HANDLE CENTERING RUBBER	
3	HLT-2003Y	HANDLE CENTERING BRKT A	
4	HLT-2004	HANDLE CENTERING SPACER A	
5	HLT-2005Y	HANDLE CENTERING BRKT B	
7	HLT-2007Y	HANDLE CENTERING SPRING DLX	
8	HLT-2008X	HANDLE MECHA BASE	
9	HLT-2009	HANDLE MECHA COVER	
10	HLT-2010	HANDLE STOPPER BRKT	
11	HLT-2011	HANDLE STOPPER SHAFT	
12	HLT-2012	HANDLE STOPPER RUBBER	
13	HLT-2013	HANDLE STOPPER BRKT	
14	HLD-2105	GEAR HOLDER	
15	HLD-2116X	GEAR PLATE	
16	123-050515-2R	KEY 5x5x15 2R	
17	601-7945	GEAR 20	
18	601-10003	GEAR 80	
101	100-5266	BEARING FAI25 (6005ZZ)	
102	220-5753	VOL CONT B-5K OHM (TOCOS)	
103	310-5029-F20	SUMITUBE F F 20MM	
104	280-5277	CORD CLAMP 18	
201	000-P00508-W	M SCR PH W/FS M5x8	
202	030-000816-S	HEX BLT W/S M8x16	
203	060-F00800	FLT WSHR M8	
204	050-H00800	HEX NUT M8	
205	060-S00800	SPR WSHR M8	
206	000-P00412-W	M SCR PH W/FS M4x12	
207	030-001020-S	HEX BLT W/S M10x20	
208	060-F01000	FLT WSHR M10	
209	028-A00308-P	SET SCR HEX SKT CUP P M3x8	
210	060-F00600	FLT WSHR M6	
301	HLT-60034	WH HANDLE UNIT	

15 ASSY HANDLE DLX (HLT-2100)



ITEM NO.	PART NO.	DESCRIPTION	NOTE
1	HLT-2500	ASSY BRAKE MECHA	
2	HLT-2600	ASSY THROTTLE	
3	HLT-2700	ASSY SHIFT SWITCH	
4	HLT-2101X	HANDLE BAR DLX	
5	HLD-3035	HANDLE MOUNT	
6	HLT-2102X	HANDLE HOLDER	
7	HLT-2103	GRIP L	
8	HLT-2104	HANDLE FRONT TUBE PLATE	
9	HLT-2105X	WIRE STAY	
10	HLT-2106	HANDLE FRONT TUBE BRKT	
101	601-6788	PLASTIC TIE BELT BLACK 4.8x188	
102	601-11017	PLASTIC TIE BELT BLACK 100MM	
201	008-T00408-0B	TMP PRF SCR TH BLK M4x8	
202	020-000620-0Z	HEX SKT H CAP SCR BLK 0Z M6x20	
203	060-S00600	SPR WSHR M6	
204	060-F00600	FLT WSHR M6	
205	050-F00300	FLG NUT M3	
206	050-H00400	HEX NUT M4	
207	060-S00400	SPR WSHR M4	
208	060-F00400	FLT WSHR M4	
209	000-P00408-WB	M SCR PH W/FS BLK M4x8	
210	060-F00300-0B	FLT WSHR BLK M3	

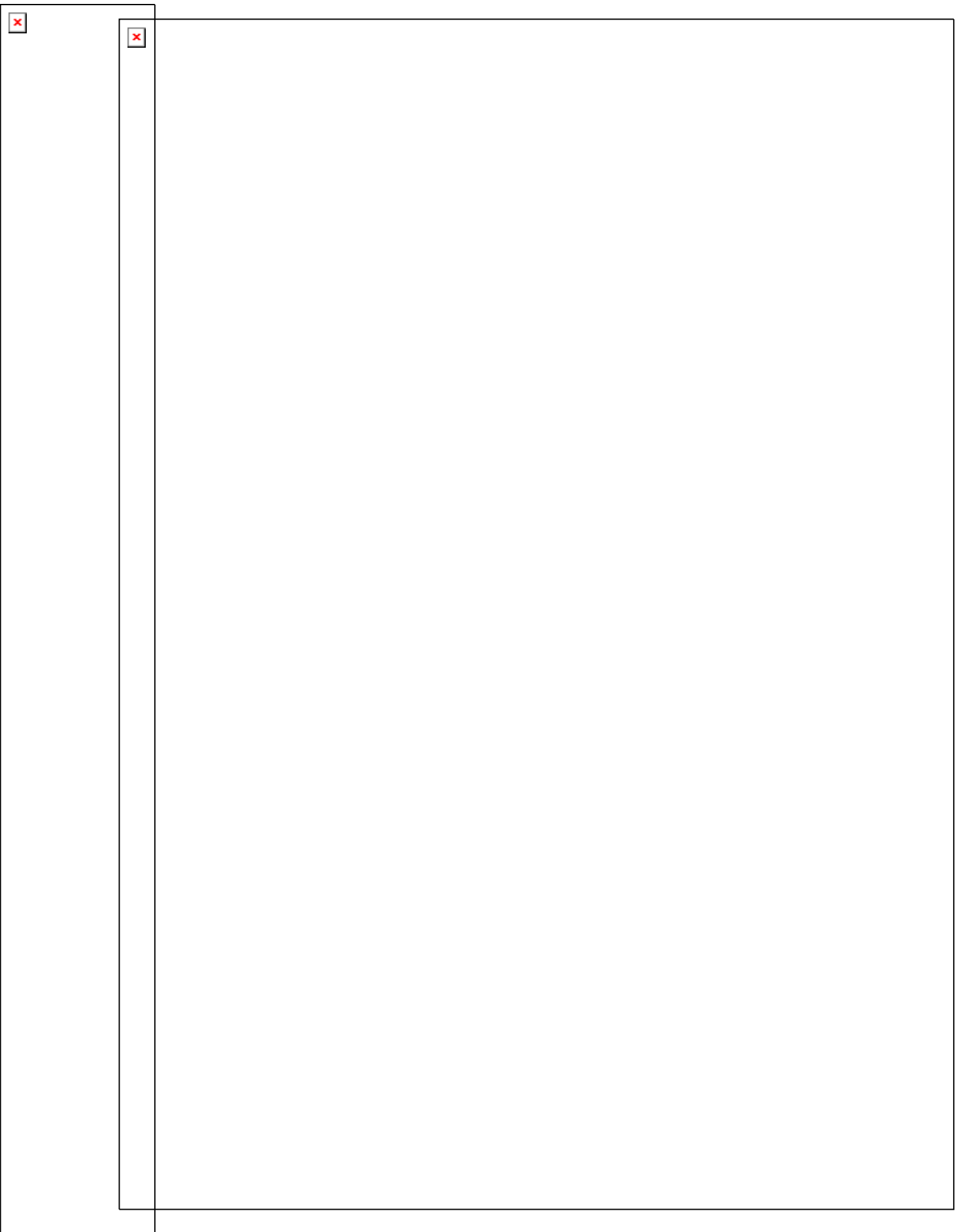

16 ASSY BRAKE MECHA (HLT-2500)**(D-2/2)**

ITEM NO.	PART NO.	DESCRIPTION	NOTE
1	HLD-2501	BRAKE MASTER CASE	
2	HLD-2502	MASTER CASE HOLDER	
3	HLD-2503X	MASTER CASE COVER	
4	HLD-2504	BRAKE GEAR	
5	HLD-2505	IDOL GEAR	
6	HLD-2506	PIVOT SHAFT	
7	HLT-2502	BRAKE VR BRKT	
8	HLD-2508	LEVER STOPPER	
9	HLD-2509	IDOL GEAR SHAFT	
10	WRD-2551	MASTER PISTON	
11	280-6619	RUBBER FOOT T 3G	
12	HLD-2512	BRAKE LEVER RETURN SPRING	
13	HLD-2514	GEAR 15	
14	601-7944	VR COVER	
15	HLD-2513	PROTECT TUBE	
16	HLT-2504		
101	220-5753	VOL CONT B-5K OHM (TOCOS)	
102	310-5029-F20	SUMITUBE F F 20MM	
201	030-000625-SB	HEX BLT W/S BLK M6x25	
202	060-F00600-0B	FLT WSHR BLK M6	
203	008-T00408-0B	TMP PRF SCR TH BLK M4x8	
204	FAS-500015	CAP NUT BLK M6	
205	000-P00408-W	M SCR PH W/FS M4x8	
206	050-C00400-3B	CAP NUT TYPE3 BLK M4	
207	028-A00306-P	SET SCR HEX SKT CUP P M3x6	
208	000-P00408	M SCR PH M4x8	
209	080-S00400	SPR WSHR M4	
210	060-F00400	FLT WSHR M4	
301	HLT-60035	WH BRAKE MECHA	



17 ASSY THROTTLE (HLT-2600)**(D-2/2)**

ITEM NO.	PART NO.	DESCRIPTION	NOTE
1	HLD-2601	THROTTLE CASE LOWER	
2	HLD-2602	THROTTLE CASE UPPER	
3	HLD-2603	INNER GRIP	
4	HLD-2604	ACCEL GEAR	
5	HLD-2605	BASE PLATE	
6	HLD-2606	ACCEL GEAR SHAFT	
7	HLD-2607X	ACCEL VR BRKT	
8	HLD-2608	SPRING HOOK	
9	HLD-2609	RETURN SPRING	
10	HLD-2610	VR COVER	
11	HLT-2605	SLIDE PLATE	
12	HLD-2612	SPRING STOPPER	
13	HLD-2613X	GEAR SPRING	
14	HLD-2614	GEAR 15	
15	601-7944	PROTECT TUBE	
16	HLT-2504		
101	220-5753	VOL CONT B-5K OHM (TOCOS)	
102	310-5029-F20	SUMITUBE F F 20MM	
201	030-000625-SB	HEX BLT W/S BLK M6x25	
202	060-F00600-0B	FLT WSHR BLK M6	
203	000-F00408	M SCR FH M4x8	
204	008-T00408-0B	TMP PRF SCR TH BLK M4x8	
205	000-P00408-W	M SCR PH W/FS M4x8	
206	012-P00306	TAP SCR #2 PH 3x6	
207	028-A00306-P	SET SCR HEX SKT CUP P M3x6	
301	HLT-60036	WH THROTTLE	

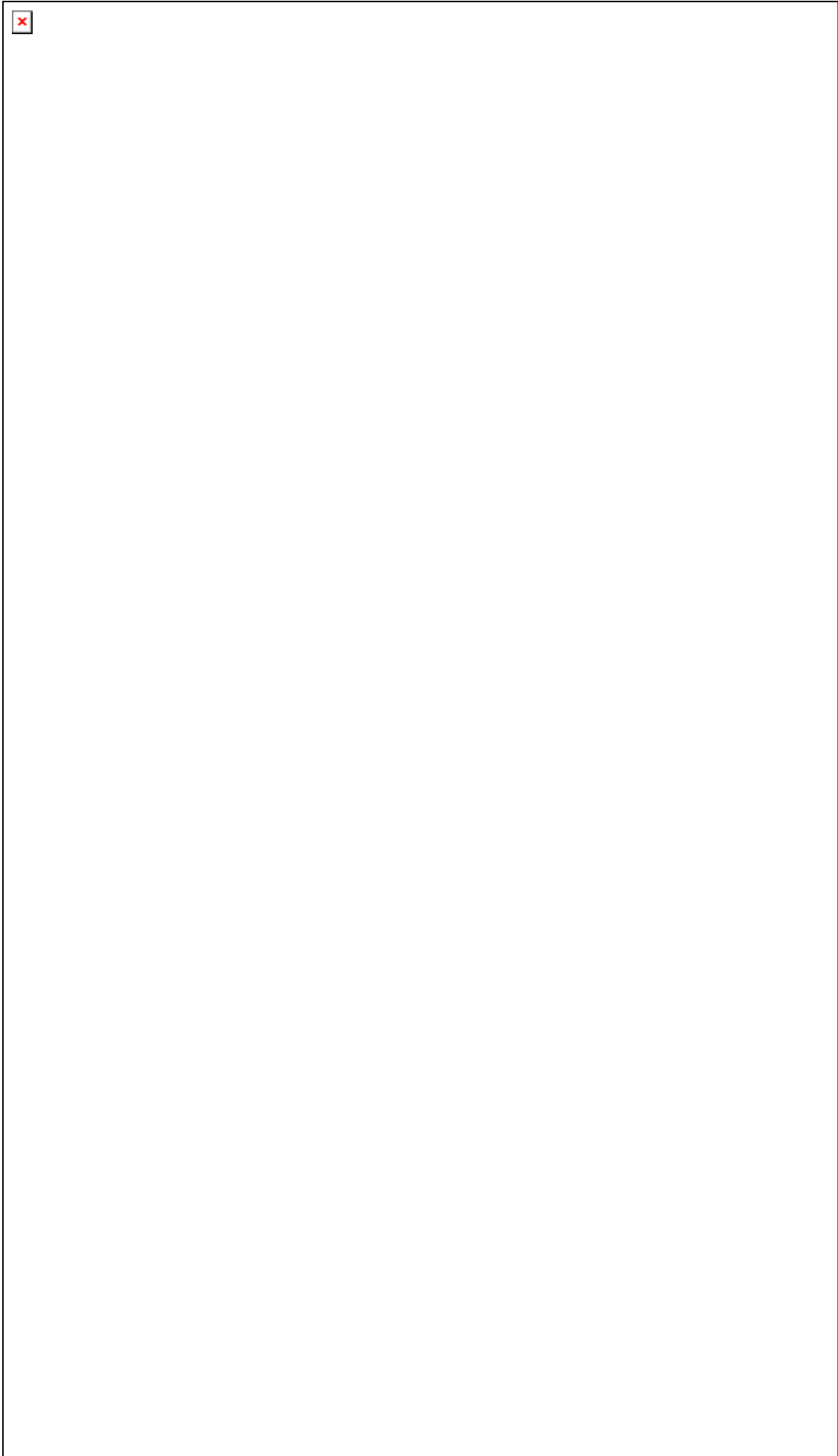
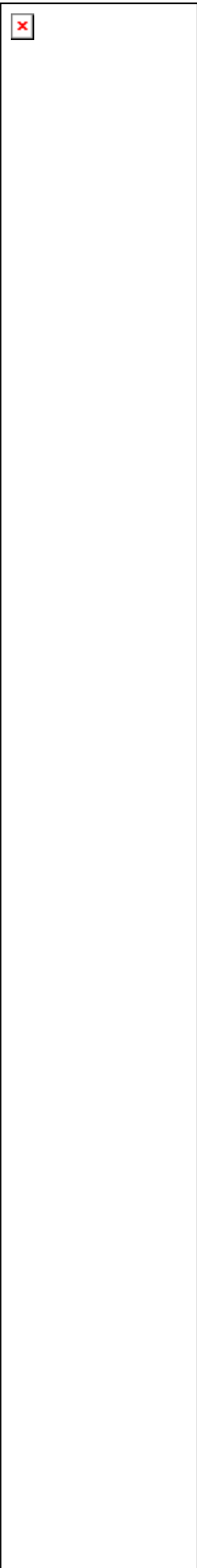

18 ASSY SHIFT SWITCH (HLT-2700)**(D-2/2)**

ITEM NO.	PART NO.	DESCRIPTION	NOTE
1	HLT-2701	SHIFT BASE A	
2	HLT-2702	SHIFT BASE B	
3	HLT-2703	SHIFT SHAFT	
4	HLT-2704X	SHIFT SPRING	
5	HLT-2705	SHIFT SW	
6	HLT-2706	SHIFT SHAFT BRKT	
7	HLT-2707	SHIFT SENSOR BRKT A	
8	HLT-2708	SHIFT SENSOR BRKT B	
9	HLT-2709X	SHIFT TUBE BRKT	
10	HLT-2710	STICKER SHIFT	
11	HLT-6001	ASSY WIRE TUBE SHIFT	
101	370-5297	PHOTO INTERRUPTER GP1A75EJ000F	
201	000-P00408-W	M SCR PH W/FS M4x8	
202	000-P00308-W	M SCR PH W/FS M3x8	
203	000-P00308	M SCR PH M3x8	

19 ASSY WIRE TUBE SHIFT (HLT-6001)

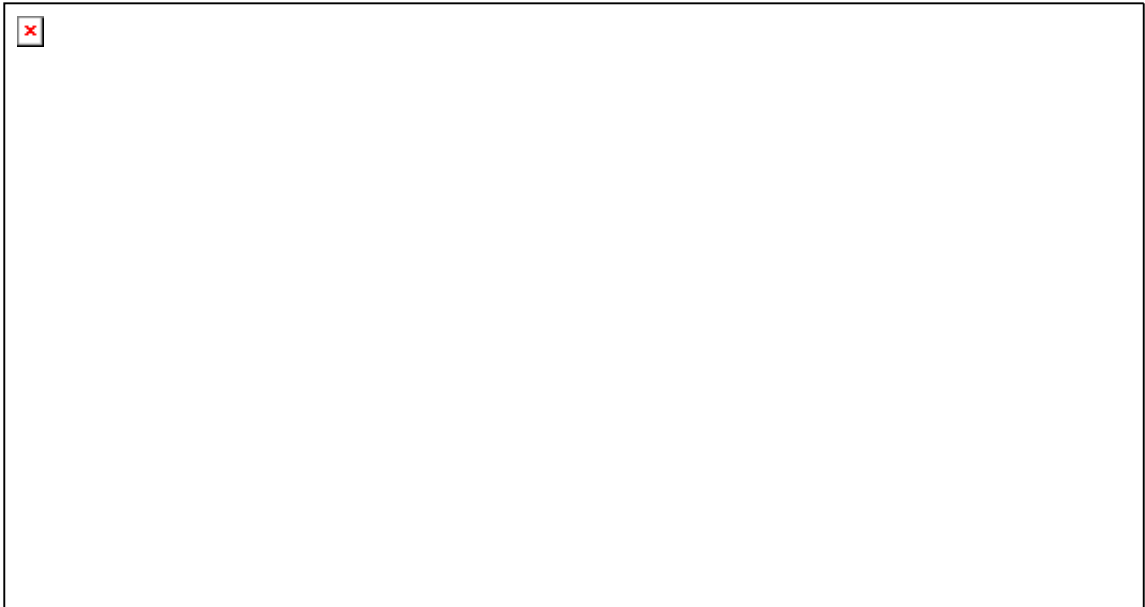
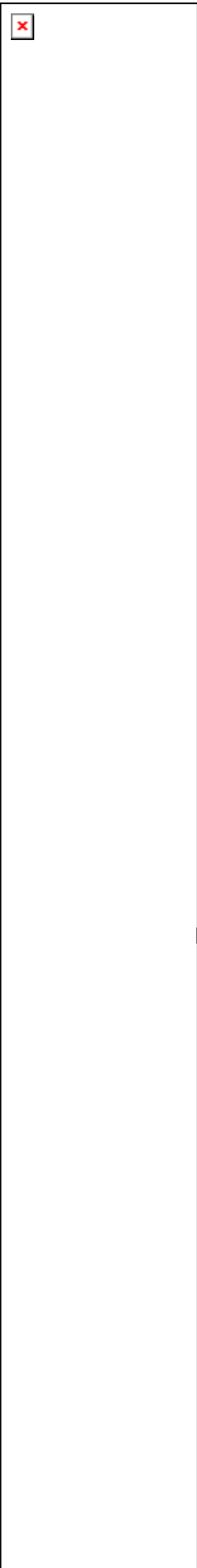

ITEM NO.	PART NO.	DESCRIPTION	NOTE
1	HLT-2701	PROTECT TUBE	
301	HLT-60037X	WH SHIFT SW	

20 ASSY WOOFER (HLT-3300)



ITEM NO.	PART NO.	DESCRIPTION	NOTE
1	HLT-3301	WOOFER BRKT L	
2	HLT-3302	WOOFER BRKT R	
101	130-5218-01	SUB WOOFER 4OHM 40W YL	
201	012-T00412	TAP SCR #2 TH 4x12	



21 ASSY ROLL VOLUME (HLT-3320)

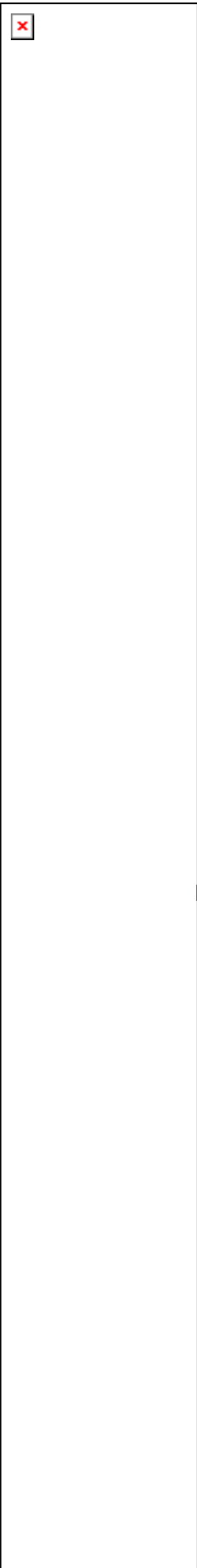

ITEM NO.	PART NO.	DESCRIPTION	NOTE
1	HLT-3321	ROLL VOLUME BRKT	
2	601-7944	GEAR 15	
101	220-5753	VOL CONT B-5K OHM (TOCOS)	
102	310-5029-F20	SUMITUBE F F 20MM	
201	028-A00306-P	SET SCR HEX SKT CUP P M3x6	
301	HLT-60033	WH ROLL VOLUME	

22 ASSY SW PLATE (HLT-3350)

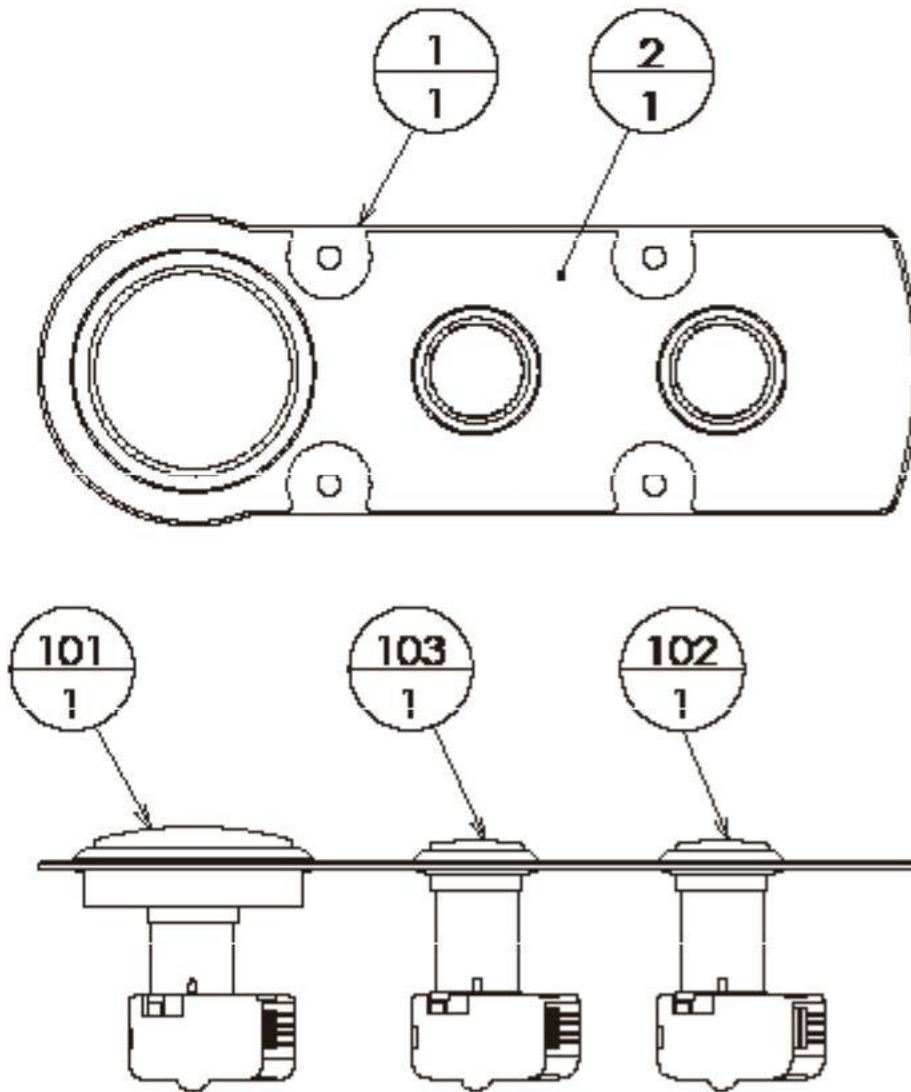

NOTE: Align (2) with the center of the relief hole when affixing it.

ITEM NO.	PART NO.	DESCRIPTION	NOTE
1	HLT-3351	TANK CENTER SW PLATE	
2	HLT-3352	STICKER CENTER SW	
101	509-6222	SW OBSA-60UM START HLT	
102	509-6223	SW OBSA-30UM MUSIC HLT	
103	509-6224	SW OBSA-30UM VIEW CHANGE HLT	
104	601-0460	PLASTIC TIE BELT 100 M/M	
301	HLT-60038	WH SW PLATE	

23 ASSY STEP L (HLT-3400)



ITEM NO.	PART NO.	DESCRIPTION	NOTE
1	HLT-3401	STEP L	
2	HLT-3402	STEP ACRYL PLATE	
3	HLT-3403	STEP MAT	
4	HLT-3404	STEP BASE	
201	050-U00400	U NUT M4	
202	060-F00400	FLT WSHR M4	

24 ASSY STEP R (HLT-3420)

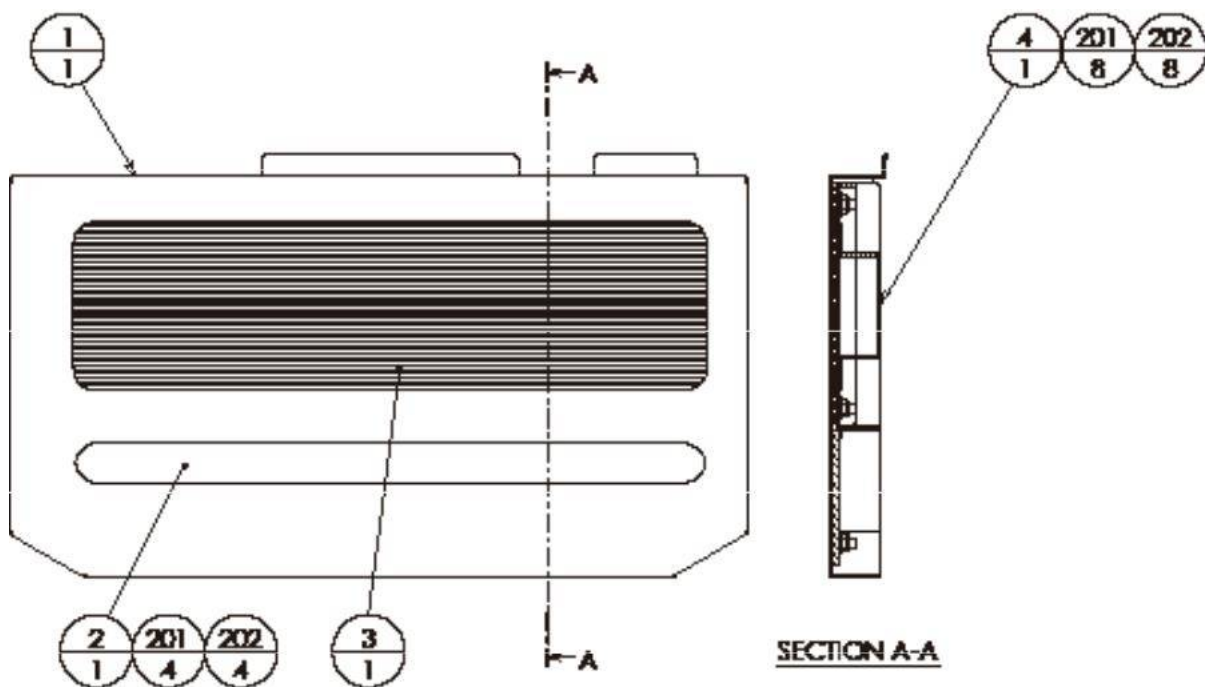

ITEM NO.	PART NO.	DESCRIPTION	NOTE
1	HLT-3421	STEP R	
2	HLT-3402	STEP ACRYL PLATE	
3	HLT-3403	STEP MAT	
4	HLT-3404	STEP BASE	
201	050-U00400	U NUT M4	
202	060-F00400	FLT WSHR M4	

25 ASSY REAR FENDER (HLT-3500)

(D-1/2)

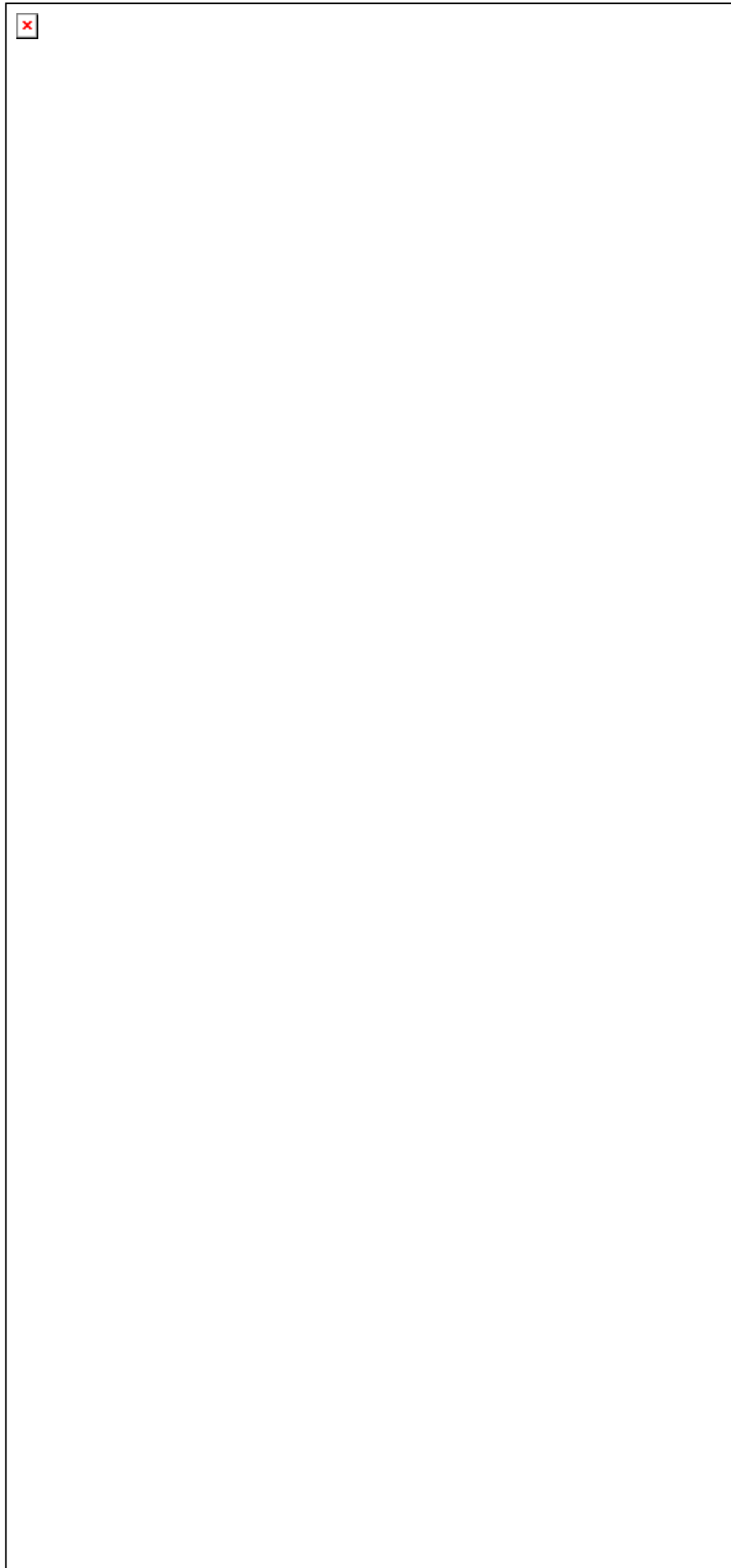
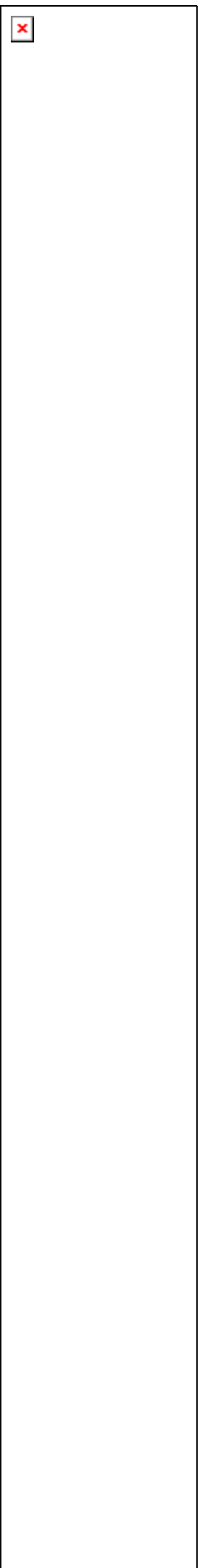

25 ASSY REAR FENDER (HLT-3500)

(D-2/2)

ITEM NO.	PART NO.	DESCRIPTION	NOTE
1	HLT-3520	ASSY TAIL LAMP	
2	HLT-3530	ASSY NUMBER PLATE	
3	HLT-3501	FENDER BASE	
4	HLT-3502	REAR FENDER	
5	HLT-3503	NUMBER PLATE BASE	
6	HLT-3504	FENDER SIDE PLATE	
7	250-5715-04	SPCL WASHER M4 HLT	
8	HLT-3505	TIRE HOLDER	
9		TIRE	
10	HLT-3506	TAIL LAMP COVER	
11	HLT-3507	TAIL LAMP OUTER COVER	
12	HLT-3508	STICKER TIRE SIDE L	
13	HLT-3509	STICKER TIRE SIDE R	
	HLT-3510		
101	280-5275-SR10	CORD CLAMP SR10	
201	000-P00410-W	M SCR PH W/FS M4x10	
202	008-T00410-0B	TMP PRF SCR TH BLK M4x10	
203	068-441616-0B	FLT WSHR BLK 4.4-16x1.6	
204	FAS-290042	HEX SKT LH CAP SCR STN M4x12	
205	060-S00400	SPR WSHR M4	
206	008-T00416-0C	TMP PRF SCR TH CRM M4x16	
207	068-441616-0C	FLT WSHR CRM 4.4-16x1.6	
208	000-P00612-W	M SCR PH W/FS M6x12	
301	HLT-60042	WH REAR FENDER	



26 ASSY TAIL LAMP (HLT-3520)

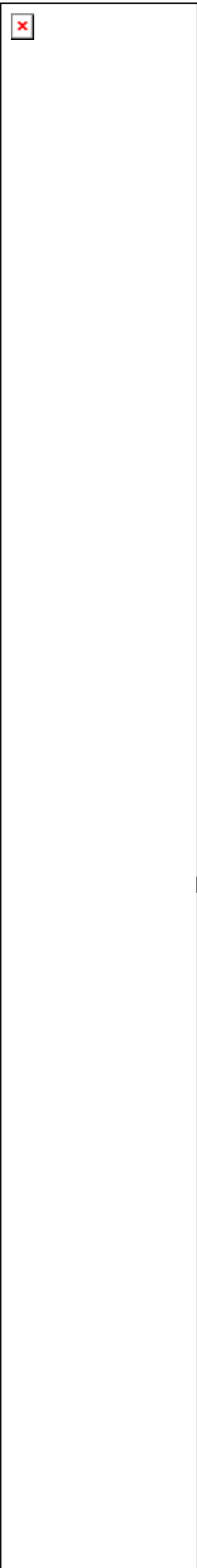

ITEM NO.	PART NO.	DESCRIPTION	NOTE
1	HLT-3521	TAIL LAMP CASE	
101	838-14590	LED BD RED 4EA	
102	280-5275-SR10	CORD CLAMP SR10	
201	000-P00308-W	M SCR PH W/FS M3x8	
301	HLT-60043	WH TAIL LAMP	

27 ASSY NUMBER PLATE (HLT-3530)



ITEM NO.	PART NO.	DESCRIPTION	NOTE
1	HLT-3531	NUMBER PLATE HOLDER	
2	HLT-3532	NUMBER PLATE COVER	
3	HLT-3533-PO	NUMBER PLATE PO	
4	440-WS0354-EG	STICKER W TANDEM HLT ENG	
201	031-000410-0B	CRG BLT BLK M4x10	
202	050-C00400-3B	CAP NUT TYPE3 BLK M4	

28 ASSY TUBE (HLT-0400)

ITEM NO.	PART NO.	DESCRIPTION	NOTE
1	HLT-0401	TUBE LID F	
2	HLT-0402	TUBE LID R	
101	310-5286-36	CONN 36	
102	310-5285-360050	FLEX TUBE 36-0050CM	
103	310-5285-360043	FLEX TUBE 36-0043CM	
201	050-H00400	HEX NUT M4	
202	060-S00400	SPR WSHR M4	
203	060-F00400	FLT WSHR M4	
301	HLT-60021	WH JOINT01	
302	HLT-60022	WH JOINT02	
303	HLT-60023	WH JOINT03	
304	HLT-60024	WH JOINT04	
305	HLT-60025	WH JOINT05	
306	HLT-60046	WH E JOINT	

⚠ WARNING

The DC power wire color for this product is different from previous SEGA titles. Working from the previous wire colors will create a high risk of fire.

The color codes for the wires used in the diagrams in the following chapter are as follows.

- A PINK
- B SKY BLUE
- C BROWN
- D PURPLE
- E LIGHT GREEN

Wires other than those of any of the above 5 single colors will be displayed by 2 alphanumeric characters.

- 1 RED
- 2 BLUE
- 3 YELLOW
- 4 GREEN
- 5 WHITE
- 7 ORANGE
- 8 BLACK
- 9 GRAY

If the right-hand side numeral of the code is 0, then the wire will be of a single color shown by the left-hand side numeral (see the above).

Note 1: If the right-hand side numeral is not 0, that particular wire has a spiral color code. The left-hand side character shows the base color and the right-hand side one, the spiral color.

<Example> 51.....WHITE/RED



Note 2: The character following the wire color code indicates the size of the wire.

- U: AWG16
- K: AWG18
- L: AWG20
- None: AWG22

22 WIRING DIAGRAM (US CABINET)

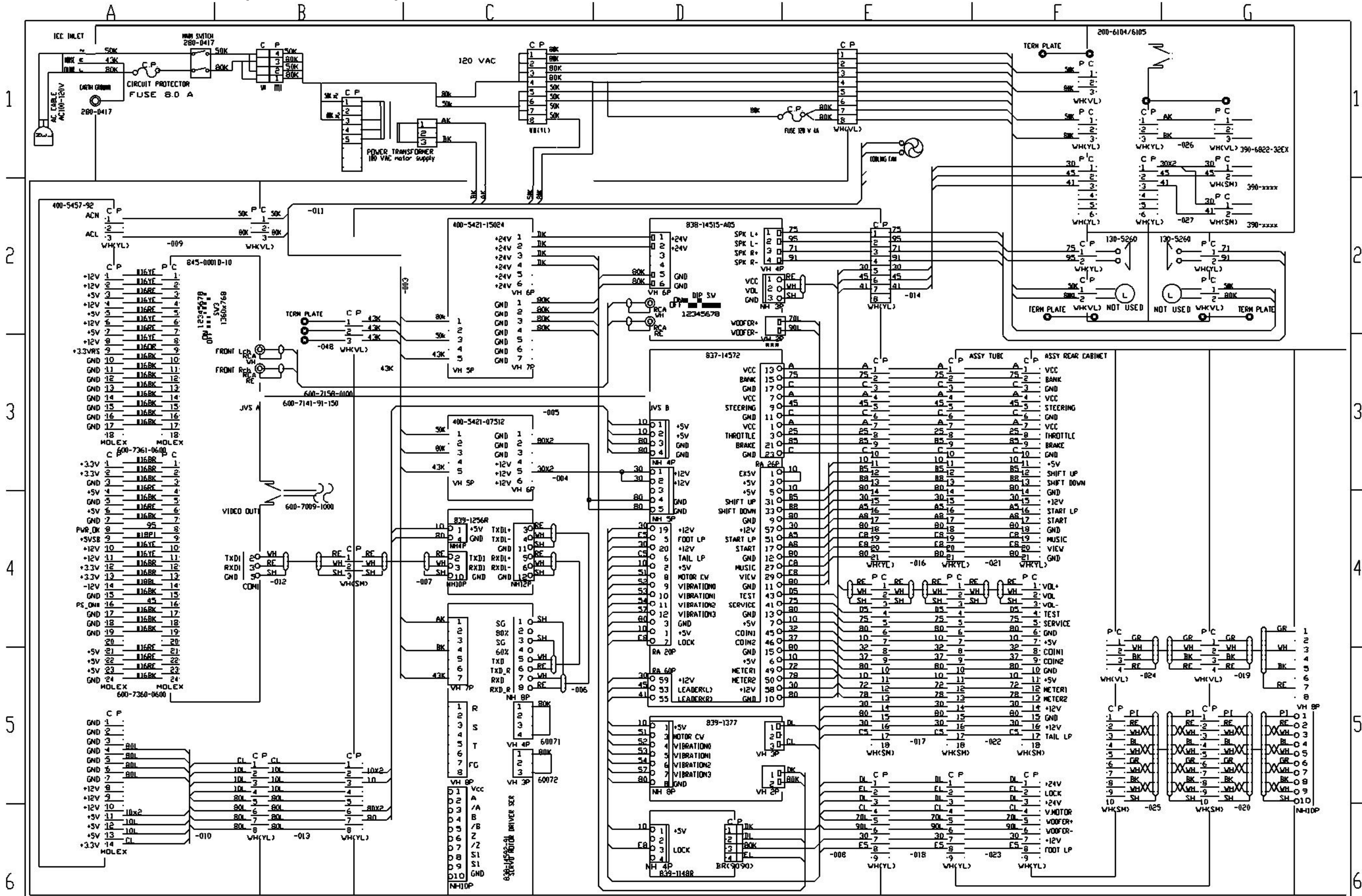

8 BLACK	C LIGHT GREEN	43 EARTH WIRE	????	????	REVISED	SEGA SEGA CORPORATION	THIS DRAWING WILL IN NO WAY BE COPIED TO BE RETURNED ON DEMAND.
7 ORANGE	D PURPLE	U AWG16 UL1015	HDT-0000	08/04-'08	GM	HARLEY DAVIDSON DLX U.S.A.	(1/3)
5 WHITE	E BROWN	K AWG18 UL1015	TOP-ASSY	00000	1/23/2009	DESCRIPTION	DIAGRAM No.
4 GREEN	F SKY BLUE	I AWG20 UL1007					
3 YELLOW	A PINK	AWG22 UL1007					
2 BLUE	9 GRAY						
1 RED							

WIRING DIAGRAM (EUROPEAN CABINET)

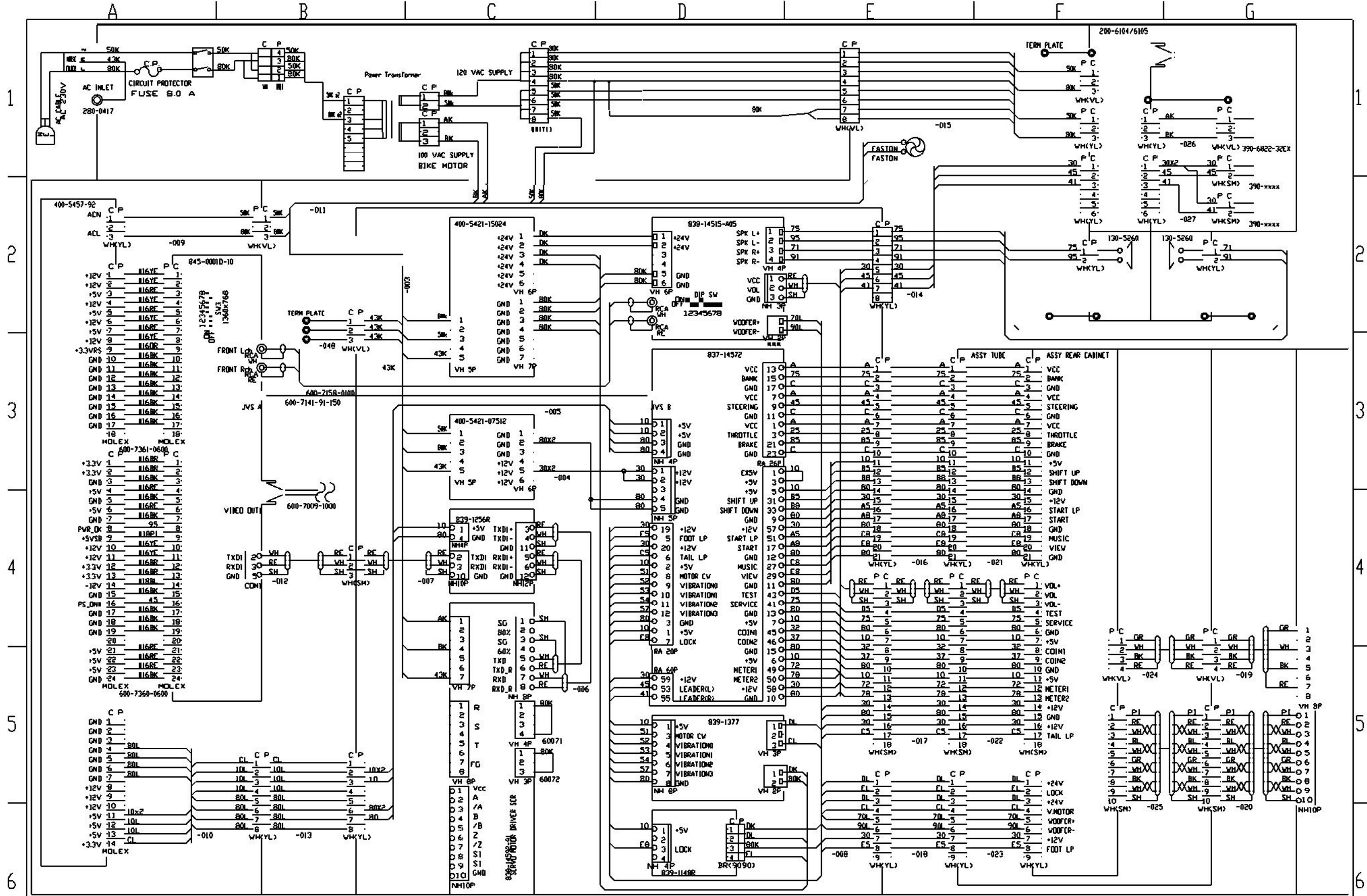

8 BLACK	E LIGHT GREEN	43 EARTH WIRE	????	????	REVISED	SEGA SEGA CORPORATION HARLEY DAVIDSON DLX EUROPE	THIS DRAWING WILL IN NO WAY BE COPIED. TO BE RETURNED ON DEMAND.
7 ORANGE	F PURPLE	44 AMG18 14.1015	000000	000000	GM		
6 WHITE	G BROWN	45 AMG18 14.1015	000000	000000	01/23/2009	DESCRIPTION	DIAGRAM No.
5 GREEN	H BROWN	46 AMG18 14.1015					
4 GREEN	I BROWN	47 AMG18 14.1015					
3 YELLOW	J SKY BLUE	48 AMG18 14.1015					
2 BLUE	K PINK	49 AMG18 14.1015					
1 RED	L GRAY	50 AMG18 14.1015					

